

"Universal Constructions for Monads on Internal Categories and Morita Contexts"

Adrian Vazquez Marquez

September 29, 2010

DECLARATION

This work has not previously been accepted in substance for any degree and is not being concurrently submitted in candidature for any degree.

Signed

Date

STATEMENT 1

This thesis is the result of my own investigations, except where otherwise stated. Where correction services have been used, the extent and nature of the correction is clearly marked in a footnote(s).

Other sources are acknowledged by footnotes giving explicit references. A bibliography is appended.

Signed

Date

STATEMENT 2

I hereby give consent for my thesis, if accepted, to be available for photocopying and for inter-library loan, and for the title and summary to be made available to outside organisations.

Signed

Date

Acknowledgments

I would like to thank to my wife Alejandra Vieyra for her support and encouraging words in this project.

I would like to thank to my parents Felix Vazquez and Amanda Marquez for their advice, emotional and financial support, and who encouraged me to study Physics and Mathematics, to my brothers Felix Octavio and Gabriel Vazquez who were also a source of support for the years I have been away from home.

I would like to thank to my adviser Tomasz Brzezinski for having accepted me as a PhD student first and afterwards for his guidance through these years. I really appreciate his kind disposition to have a discussion at any time. I am also honoured to have been his student.

I would like to thank to Swansea University and, in particular, to the staff of the Department of Mathematics for the professional and technical support.

I would like to thank also to my friends in Mexico who supported me each time I was there visiting them and to my friends in Swansea who made this thesis even harder to write and finish.

I would like to thank to the city of London to make me feel far less away from home and for its inspirational atmosphere.

I also would like to thank to the examiners Stefaan Caenepeel and Edwin Beggs for useful comments on this thesis.

Last but not least, to the Consejo Nacional de Ciencia y Tecnologia, CONACYT, who support me financially through the grant no. 208351/303031 and without which none of this would have been possible.

Contents

Acknowledgments	v
Introduction	ix
1 Internal Categories in a Monoidal Category	1
1.1 Internal Categories	1
1.2 Monoidal Categories	5
1.2.1 Examples of Monoidal Categories	6
1.2.2 Comonoids and Comodules in a Monoidal Category	7
1.3 Towards Generalization of Internal Categories	10
1.4 Internal Categories in a Monoidal Category	12
1.4.1 Examples of Internal Categories	14
1.4.2 Internal Functors and Natural Transformations	15
1.5 2-Categories	16
1.5.1 Definition of 2-Categories	16
1.5.2 Examples of 2-Categories	18
1.5.3 $\mathbf{IntCat}(\mathfrak{M})$ as a 2-category	21
1.5.4 $\mathbf{IntCoCat}(\mathfrak{M})$ as a 2-category	25
2 Classical and Formal Theories of Monads	29
2.1 Monads and the Associated Category of Adjunctions	29
2.2 Comonads and the Associated Category of Adjunctions	36
2.3 Formal Theory of Monads	38
2.3.1 The 2-Category $\mathbf{KL}(\mathcal{A})$	47
2.3.2 Wreaths	48
3 Internal Kleisli Categories	51
3.1 Monads and Adjunctions in the 2-Category $\mathbf{IntCat}(\mathfrak{M})$	51
3.2 Explicit Construction of Kleisli Objects in $\mathbf{IntCat}(\mathfrak{M})$	53
3.2.1 Sweedler Notation	53
3.2.2 Kleisli Objects in $\mathbf{IntCat}(\mathfrak{M})$	55
3.2.3 CoKleisli Objects in $\mathbf{IntCat}(\mathfrak{M})$	71
3.3 Internal Kleisli Objects and the Formal Theory of Monads	74
3.3.1 The Bicategory of $\mathbf{KL}(\mathbf{Bicomod}(\mathfrak{M}))$	75
3.3.2 Bifunctors	77
3.3.3 Wreaths in $\mathbf{IntCat}(\mathfrak{M})$	84
3.4 String Diagrams	86
3.5 Binatural Maps and Adjunctions in $\mathbf{IntCat}(\mathfrak{M})$	88

3.5.1	Alternative Proof of the Characterization of Adjunctions	101
3.6	Kleisli Objects Induced by Mates under Adjunctions	104
3.7	Example	105
4	Morita Contexts and Double Adjunctions	107
4.1	Double Adjunctions	107
4.2	Morita Contexts	108
4.3	Adjunction between $\mathbf{Mor}(\mathcal{A}, \mathcal{B})$ and $\mathbf{Adj}(\mathcal{A}, \mathcal{B})$	112
4.3.1	The Left Adjoint	112
4.3.2	The Right Adjoint	122
4.3.3	The Unit and the Counit of the Adjunction	126
4.4	Moritability	134
4.5	Example	151
4.5.1	Categories with Binary Coproducts	151
Appendix		153
A	Structural Properties of $\mathbf{IntCat}(\mathfrak{M})$	153
Bibliography		161

Introduction

This thesis is split into two parts. The first part is concerned with the search for Kleisli (coKleisli) objects for monads (comonads) in the category of internal categories for a monoidal category as introduced in [2]. The second part is concerned with the construction of Eilenberg-Moore algebras for a Morita context as in [11]. The reader should note that these two parts are related through the theory of monads. The first part deals with the formal theory of monads in 2-categories and the second part with the classical theory of monads in the usual category theory and extends it from a single adjunction to a pair of adjunctions which is a particular example of a span.

The importance of these objects rest on the fact that they are universal constructions and therefore important on their own, even though there are not too many applications or examples inside this thesis.

This thesis is organized as follows. In Chapter 1, a revision of the definition of an *internal category* is done. An internal category is the generalization of a small category within the category of **Sets**, but it can exist inside any category \mathcal{C} , with finite products and pullbacks.

Internal categories within monoidal categories have been introduced and studied by M. Aguiar in his PhD thesis [2] as a framework for analysing properties of quantum groups. By choosing appropriately the monoidal category \mathfrak{M} , algebraic structures of recent interest in Hopf algebra theory, such as corings and C -rings, can be interpreted as internal categories. Internal categories can be organised into two different 2-categories. The first one, denoted by $\mathbf{IntCat}(\mathfrak{M})$, has internal functors as 1-cells, and internal natural transformations as 2-cells. The second one, denoted by $\mathbf{IntCoCat}(\mathfrak{M})$, has internal cofunctors as 1-cells, and internal natural cotransformations as 2-cells. The difference between these two structures is that the internal functors can be thought of as a push-forward of morphisms while the cofunctor can be understood as a lifting of morphisms from one internal category to the other.

In Chapter 2, the necessary background to deal with monads is given, both in the classical sense and in the formal sense; see [3] for the classical treatment and [20], [24] for the formal theory. In the formal theory of monads the main role is played by a 2-category $\mathbf{KL}(\mathcal{A})$, defined over a 2-category \mathcal{A} , which has the particular feature of having all Kleisli objects for any monad defined in there. In [20], the authors not only provide this 2-category with all the Kleisli objects but also they give the algorithm to get the Kleisli object out of a the monad defined there, this last property will be exploited in this thesis.

Chapter 3, which is based on [10], contains the original results of this thesis. It starts with a quick review of the definition of a monad in the 2-category $\mathbf{IntCat}(\mathfrak{M})$. A monad (comonad) in the 2-category $\mathbf{IntCat}(\mathfrak{M})$, *i.e.* an internal endofunctor with two natural transformations

which satisfy the usual associativity and unitality conditions, is called an *internal monad* (*internal comonad*). We show that every internal monad (comonad) arises from and gives rise to a pair of adjoint functors, by explicitly constructing the Kleisli internal category in $\mathbf{IntCat}(\mathfrak{M})$. A monad in the 2-category $\mathbf{IntCoCat}(\mathfrak{M})$, *i.e.* an internal endofunctor with two natural cotransformations which satisfy the usual associativity and unital conditions, is also called an *internal monad*. Similarly as before, we show that every internal monad arises from and give rise to a pair of adjoint cofunctors, by explicitly constructing Kleisli objects in $\mathbf{IntCoCat}(\mathfrak{M})$. Both constructions are based on the definition of the classical Kleisli category and the proofs that these indeed give Kleisli objects are given along the same lines as in [24].

Further in the chapter, the *bicategory* $\mathbf{Bicomod}(\mathfrak{M})$ is constructed and the associated bicategory $\mathbf{KL}(\mathbf{Bicomod}(\mathfrak{M}))$ is described. This last bicategory is needed in order to construct several bifunctors which have this bicategory or one of its duals, as a codomain. A main common feature of these bifunctors is that they are identities on objects and are full embeddings. Now if such a bifunctor $\Phi : \mathbf{IntCat}(\mathfrak{M}) \longrightarrow \mathbf{KL}(\mathbf{Bicomod}(\mathfrak{M}))$ is constructed, then any monad in $\mathbf{IntCat}(\mathfrak{M})$ can be pushed-forward into $\mathbf{KL}(\mathbf{Bicomod}(\mathfrak{M}))$, and once it is there one can use the aforementioned algorithm to get the Kleisli object for it, which happens to be in $\mathbf{IntCat}(\mathfrak{M})$. The method just explained is used to obtain the Kleisli object for any monad and the coKleisli object for any comonad in $\mathbf{IntCat}(\mathfrak{M})$ and the Kleisli object for any monad in $\mathbf{IntCoCat}(\mathfrak{M})$.

Later on, in the same chapter and based on the definition of the Kleisli object for a monad, a new characterization of an adjunction in $\mathbf{IntCat}(\mathfrak{M})$ is given. This characterization resembles that of an isomorphism between the *Hom* sets for a classical adjunction between categories.

In Chapter 4, which is based on [11], a connection between functorial Morita contexts and pairs of adjunctions is described. This correspondence is similar to that between (single) adjunctions and monads, more precisely, between adjunctions with domain a fixed category \mathcal{C} and the category of Eilenberg-Moore algebras \mathcal{C}^F for a monad (F, μ^F, η^F) over \mathcal{C} . The role of the adjunctions will be played by the so-called category of *double adjunctions* and the role of \mathcal{C}^F will be played by the category of *Eilenberg-Moore algebras* $(\mathcal{A}, \mathcal{B})^{(A, B)}$ for a Morita context (A, B, T, \hat{T}) . Given this resemblance, this thesis concludes with a Beck-type theorem for such a relation.

Chapter 1

Internal Categories in a Monoidal Category

1.1 Internal Categories

This section is based on [7] and [13]. Let \mathcal{A} be a category with pullbacks. An internal category \mathcal{I} in \mathcal{A} consists of the following data:

- i) An internal reflexive graph¹, *i.e.* a diagram

$$A_1 \begin{array}{c} \xrightarrow{d} \\ \xleftarrow{i} \\ \xrightarrow{c} \end{array} A_0, \quad (1.1)$$

such that

$$d \cdot i = 1_{A_0} = c \cdot i. \quad (1.2)$$

The morphisms d and c are called *domain* and *codomain* morphisms, respectively, or source and target as in [7]; and the morphism i is called *identity* morphism. Throughout this thesis a composition of morphisms in the category \mathcal{A} is denoted by \cdot and the identity morphism for the object A is denoted by 1_A .

- ii) A composition $m : A_1 \times_{A_0} A_1 \rightarrow A_1$, where $A_1 \times_{A_0} A_1$ is the pullback of c and d , *i.e.*,

$$\begin{array}{ccc} A_1 \times_{A_0} A_1 & \xrightarrow{p_2} & A_1 \\ p_1 \downarrow & & \downarrow c \\ A_1 & \xrightarrow{d} & A_0 \end{array} . \quad (1.3)$$

We will write $g \cdot f = m(g, f)$, where (g, f) is a generalized element of $A_1 \times_{A_0} A_1$, understood as a morphism with codomain $A_1 \times_{A_0} A_1$.

This composition satisfies the following properties,

¹ Henceforth referred to, only, as an internal graph.

a) Compatibility with domain and codomain

$$c \cdot m = c \cdot p_1, \quad (1.4a)$$

$$d \cdot m = d \cdot p_2, \quad (1.4b)$$

which, over generalized elements of A_1 , reads as

$$c(g \cdot' f) = c(g),$$

$$d(g \cdot' f) = d(f),$$

respectively.

b) Unitality:

$$m \cdot j_1 = 1_{A_1} = m \cdot j_2, \quad (1.5)$$

where j_1 and j_2 are defined by the following diagrams,

$$\begin{array}{ccc}
 A_1 & & A_1 \\
 \downarrow i \cdot c & \searrow^{1_{A_1}} & \downarrow i \cdot d \\
 A_1 \times_{A_0} A_1 & \xrightarrow{p_2} & A_1 \\
 \downarrow p_1 & & \downarrow p_1 \\
 A_1 & \xrightarrow{d} & A_0
 \end{array}
 \quad , \quad
 \begin{array}{ccc}
 A_1 & & A_1 \\
 \downarrow i \cdot c & \searrow^{1_{A_1}} & \downarrow i \cdot d \\
 A_1 \times_{A_0} A_1 & \xrightarrow{p_2} & A_1 \\
 \downarrow p_1 & & \downarrow p_1 \\
 A_1 & \xrightarrow{d} & A_0
 \end{array}
 .$$

The notation for these induced morphisms, through the pullback, will be $(i \cdot c; 1_{A_1})$. Over generalized elements these equations read:

$$i_{c(f)} \cdot' f = f = f \cdot' i_{d(f)} .$$

c) Associativity of the composition,

$$m \cdot (1_{A_1} \times_{A_0} m) = m \cdot (m \times_{A_0} 1_{A_1}), \quad (1.6)$$

where

$$\begin{aligned} 1_{A_1} \times_{A_0} m & : A_1 \times_{A_0} (A_1 \times_{A_0} A_1) \longrightarrow A_1 \times_{A_0} A_1, \\ m \times_{A_0} 1_{A_1} & : (A_1 \times_{A_0} A_1) \times_{A_0} A_1 \longrightarrow A_1 \times_{A_0} A_1, \end{aligned}$$

$$\text{and } A_1 \times_{A_0} (A_1 \times_{A_0} A_1) \cong (A_1 \times_{A_0} A_1) \times_{A_0} A_1.$$

The object A_0 should be understood as a collection of all objects in \mathcal{I} , and because of that named as the *object of objects* of the internal category \mathcal{I} . Furthermore, the object A_1 is named as *the object of morphisms or arrows* of the internal category \mathcal{I} . Then c assigns a codomain object for a morphism, d assigns a domain object for a morphism and i assigns an identity morphism for an object in A_0 . Furthermore, m is interpreted as a composition of morphisms with matching domain and codomain. This explains the notation \cdot used in *ii*). In the case, $\mathcal{A} = \mathbf{Sets}$, an internal category \mathcal{I} is simply a small category.

An internal category \mathcal{I} is denoted by $\mathcal{I} = (A_0, A_1, c, d, i, m)$, or shortly by $\mathcal{I} = (A_0, A_1)$.

Functors between internal categories $\mathcal{I} = (A_0, A_1)$ and $\mathcal{J} = (B_0, B_1)$ are defined as follows:

A functor $F = (F_0, F_1) : (A_0, A_1) \longrightarrow (B_0, B_1)$, is a pair of morphisms $F_0 : A_0 \longrightarrow B_0$ and $F_1 : A_1 \longrightarrow B_1$ satisfying the following properties:

i) Compatibility with domain, codomain and identity, respectively:

$$d_b \cdot F_1 = F_0 \cdot d_a, \quad (1.7a)$$

$$c_b \cdot F_1 = F_0 \cdot c_a, \quad (1.7b)$$

$$i_b \cdot F_0 = F_1 \cdot i_a. \quad (1.7c)$$

These equations can be written concisely as the following *serially* commutative diagram,

$$\begin{array}{ccc} A_1 & \begin{array}{c} \xrightarrow{d_a} \\ \xleftarrow{i_a} \\ \xrightarrow{c_a} \end{array} & A_0 \\ F_1 \downarrow & & \downarrow F_0 \\ B_1 & \begin{array}{c} \xrightarrow{d_b} \\ \xleftarrow{i_b} \\ \xrightarrow{c_b} \end{array} & B_0 \end{array},$$

ii) Preservation of the multiplication:

$$F_1 \cdot m_a = m_b \cdot (F_1 \times_{F_0} F_1), \quad (1.8)$$

where $F_1 \times_{F_0} F_1$ is defined through the following diagram,

$$\begin{array}{ccccc}
A_1 \times_{A_0} A_1 & \xrightarrow{p_2} & A_1 & \xrightarrow{F_1} & B_1 \\
\downarrow p_1 & \dashrightarrow^{F_1 \times_{F_0} F_1} & \downarrow p_2 & & \downarrow c \\
A_1 & & A_0 & & B_0 \\
\downarrow F_1 & & \downarrow d & & \downarrow c \\
B_1 & \xrightarrow{d} & B_0 & & B_0
\end{array}$$

Finally, a natural transformation $\alpha : F \longrightarrow G$ is a morphism $\alpha : A_0 \longrightarrow B_1$, such that

i)

$$d_b \cdot \alpha = F_0 , \quad (1.9a)$$

$$c_b \cdot \alpha = G_0 ; \quad (1.9b)$$

ii) $m_b(\alpha \cdot c_a; F_1) = m_b(G_1; \alpha \cdot d_a)$, where

$$(\alpha \cdot c_a; F_1), (G_1; \alpha \cdot d_a) : A_1 \longrightarrow B_1 \times_{B_0} B_1 .$$

For a generalized object f in A_1 , this reads explicitly as:

$$\alpha(c_a(f)) \cdot F_1(f) = G_1(f) \cdot \alpha(d_a(f)) ,$$

and hence it is the naturality condition for the transformation.

The following proposition can be stated:

Proposition 1.1.1. *Let \mathcal{A} be a category with pullbacks. Internal functors between fixed internal categories $\mathcal{I} = (A_1, A_0)$, $\mathcal{J} = (B_1, B_0)$ and internal natural transformations make a category $\mathbf{IntFunc}_{(\mathcal{I}, \mathcal{J})}$ where the composition, of $\alpha : F \rightarrow G$, $\beta : G \rightarrow H$, is given by*

$$\beta \circ \alpha = m_b \cdot (\beta; \alpha) ,$$

and the unit of F for this composition is $F_1 \cdot i_a$.

Furthermore, internal categories form a 2-category $\mathbf{IntCat}(\mathcal{A})$ with objects internal categories, 1-cells internal functors and 2-cells internal natural transformations, see (1.5.1) for the definition of a 2-Category.

1.2 Monoidal Categories

In this section the definition of a monoidal category is recalled. See [23] and [26].

A monoidal category is a sextuple $(\mathfrak{M}, \otimes, I, \alpha, \lambda, \rho)$, where \mathfrak{M} is a category together with a bifunctor,

$$\otimes : \mathfrak{M} \times \mathfrak{M} \longrightarrow \mathfrak{M} ,$$

that it is associative up to an isomorphism, and possesses a right and left unit I , only up to isomorphism. Explicitly, α, λ and ρ are natural transformations

$$\begin{aligned} \alpha_{A,B,C} : A \otimes (B \otimes C) &\xrightarrow{\cong} (A \otimes B) \otimes C , \\ \lambda_A : I \otimes A &\xrightarrow{\cong} A , \\ \rho_A : A \otimes I &\xrightarrow{\cong} A , \end{aligned}$$

such that $\lambda_I = \rho_I$. It is required also that the following diagrams commute:

$$\begin{array}{ccc} & A \otimes ((B \otimes C) \otimes D) & \\ & \swarrow^{A \otimes \alpha_{B,C,D}} \quad \searrow^{\alpha_{A,B \otimes C,D}} & \\ A \otimes (B \otimes (C \otimes D)) & & (A \otimes (B \otimes C)) \otimes D \\ \downarrow \alpha_{A,B,C \otimes D} & & \downarrow \alpha_{A,B,C \otimes D} \\ (A \otimes B) \otimes (C \otimes D) & \xrightarrow{\alpha_{A \otimes B,C,D}} & ((A \otimes B) \otimes C) \otimes D \end{array} , \quad \begin{array}{ccc} A \otimes (I \otimes B) & \xrightarrow{\alpha_{A,I,B}} & (A \otimes I) \otimes B \\ \downarrow A \otimes \lambda_B & & \downarrow \rho_{A \otimes B} \\ & A \otimes B & \end{array} \quad (1.10)$$

The left diagram is known as the *pentagonal law*. If the associativity and unitality are strict, *i.e.* the natural transformations α, λ and ρ are identities, then the monoidal category is called *strict monoidal category*, in this case the notation is $(\mathfrak{M}, \otimes, I)$. According to [23], every monoidal category is equivalent to some strict monoidal category. This theorem is called the *coherence theorem for monoidal categories*. Thus, in what follows, we treat monoidal categories as if they were strict monoidal.

Let $(\mathfrak{M}, \otimes, I, \alpha, \lambda, \rho)$ and $(\mathfrak{M}', \otimes', I', \alpha', \lambda', \rho')$ be two monoidal categories, then a *monoidal functor* $(F, \zeta) : (\mathfrak{M}, \otimes, I, \alpha, \lambda, \rho) \longrightarrow (\mathfrak{M}', \otimes', I', \alpha', \lambda', \rho')$ is a functor $F : \mathfrak{M} \longrightarrow \mathfrak{M}'$, a natural transformation

$$\zeta_{A,B} : FA \otimes' FB \longrightarrow F(A \otimes B) ,$$

and a map

$$\zeta_0 : I' \longrightarrow FI .$$

Such that the following diagrams commute

$$\begin{array}{ccc} FA \otimes' (FB \otimes' FC) & \xrightarrow{FA \otimes' \zeta_{B,C}} & FA \otimes' F(B \otimes C) & \xrightarrow{\zeta_{A, B \otimes C}} & F(A \otimes (B \otimes C)) \\ \downarrow \alpha'_{FA, FB, FC} & & & & \downarrow F\alpha_{A, B, C} \\ (FA \otimes' FB) \otimes' FC & \xrightarrow{\zeta_{A, B} \otimes' FC} & F(A \otimes B) \otimes' FC & \xrightarrow{\zeta_{A \otimes B, C}} & F((A \otimes B) \otimes C) \end{array} ,$$

$$\begin{array}{ccc} FA \otimes' I' & \xrightarrow{\rho'_{FA}} & FA \\ \downarrow FA \otimes' \zeta_0 & & \uparrow F\rho_A \\ FA \otimes' FI & \xrightarrow{\zeta_{A, I}} & F(A \otimes I) \end{array} , \quad \begin{array}{ccc} I' \otimes' FA & \xrightarrow{\lambda'_{FA}} & FA \\ \downarrow \zeta_0 \otimes' FA & & \uparrow F\lambda_A \\ FI \otimes' FA & \xrightarrow{\zeta_{I, A}} & F(I \otimes A) \end{array} .$$

If the natural transformation ζ and the map ζ_0 are isomorphisms, then the functor is called *strong monoidal functor*, and if they are identities then is called *strict monoidal functor*.

1.2.1 Examples of Monoidal Categories

-) The monoidal category $(\mathbf{Sets}, \times, \{*\})$ of *Sets*, where the tensor product is played by the cartesian product and the unit is the singleton set $\{*\}$.
-) The monoidal category $(\mathbf{Vect}, \otimes, k)$ of *Vector Spaces* over the field k , with the usual tensor product and unit the field itself.
-) The monoidal category $(\mathbf{Mod}_R, \otimes_R, R)$ of modules over a commutative ring with unit R , with the usual tensor product and unit the ring itself.
-) Let $(\mathfrak{M}, \otimes, I)$ be a monoidal category, then the category \mathfrak{M}^{op} is also monoidal with the same tensor product and unit, *i.e.* $(\mathfrak{M}^{op}, \otimes, I)$ is a monoidal category.

1.2.2 Comonoids and Comodules in a Monoidal Category

Let $(\mathfrak{M}, \otimes, I)$ be a strict monoidal category. A *comonoid* in $(\mathfrak{M}, \otimes, I)$ is a triple $(C, \Delta_C, \varepsilon_C)$, where C is an object in \mathfrak{M} , $\Delta_C : C \rightarrow C \otimes C$ and $\varepsilon_C : C \rightarrow I$ are morphisms in \mathfrak{M} such that the following diagrams commute:

$$\begin{array}{ccc}
 C \otimes C \otimes C & \xleftarrow{C \otimes \Delta_C} & C \otimes C \\
 \uparrow \Delta_{C \otimes C} & & \uparrow \Delta_C \\
 C \otimes C & \xleftarrow{\Delta_C} & C
 \end{array}
 , \quad
 \begin{array}{ccc}
 C & \xleftarrow{C \otimes \varepsilon_C} & C \otimes C \\
 \uparrow \varepsilon_{C \otimes C} & \searrow = & \uparrow \Delta_C \\
 C \otimes C & \xleftarrow{\Delta_C} & C
 \end{array}
 . \quad (1.11)$$

The property corresponding to the first diagram is usually referred to as the *coassociativity* of the comonoid and the second one is referred to as the *counitality* of the comonoid.

A morphism of comonoids $f_0 : (C, \Delta_C, \varepsilon_C) \rightarrow (D, \Delta_D, \varepsilon_D)$, is a morphism $f_0 : C \rightarrow D$ in \mathfrak{M} such that the following diagrams commute:

$$\begin{array}{ccc}
 C \otimes C & \xrightarrow{f_0 \otimes f_0} & D \otimes D \\
 \uparrow \Delta_C & & \uparrow \Delta_D \\
 C & \xrightarrow{f_0} & D
 \end{array}
 , \quad
 \begin{array}{ccc}
 & I & \\
 \varepsilon_C \nearrow & & \nwarrow \varepsilon_D \\
 C & \xrightarrow{f_0} & D
 \end{array}
 . \quad (1.12)$$

The category of comonoids in \mathfrak{M} is denoted by $\mathbf{Comon}_{\mathfrak{M}}$.

Let $(C, \Delta_C, \varepsilon_C)$ be a comonoid in $\mathbf{Comon}_{\mathfrak{M}}$. A *left C -comodule* is a pair $(M, {}^C\rho_M)$, where M is an object in \mathfrak{M} and ${}^C\rho_M : M \rightarrow C \otimes M$ a morphism in \mathfrak{M} , called *left C -coaction*. The left C -coaction is required to satisfy the commutativity of the following diagrams:

$$\begin{array}{ccc}
 C \otimes C \otimes M & \xleftarrow{\Delta_{C \otimes M}} & C \otimes M \\
 \uparrow C \otimes {}^C\rho_M & & \uparrow {}^C\rho_M \\
 C \otimes M & \xleftarrow{{}^C\rho_M} & M
 \end{array}
 , \quad
 \begin{array}{ccc}
 M & \xleftarrow{\varepsilon_{C \otimes M}} & C \otimes M \\
 \uparrow = & & \uparrow {}^C\rho_M \\
 M & & M
 \end{array}
 .$$

The first diagram is referred to as the *coassociativity* of the left C -coaction and the second one as the *counitality* of the left C -action.

The *morphism of left C -comodules* is a morphism $f : M \rightarrow M'$ in \mathfrak{M} such that the following diagram commute:

$$\begin{array}{ccc}
C \otimes M & \xrightarrow{C \otimes f} & C \otimes M' \\
\uparrow c_{\rho_M} & & \uparrow c_{\rho_{M'}} \\
M & \xrightarrow{f} & M'
\end{array} ,$$

The category, which has left C -comodules as its objects and morphisms of left C -comodules as morphisms, is called *the category of left C -comodules* and it is denoted by ${}^C\mathcal{M}$. With this notation, a morphism of left C -comodules can also be referred to, in a simpler manner, as *a morphism in ${}^C\mathcal{M}$* . Symmetrically, a *right C -comodule* is a pair (M, ρ_M^C) , where M is an object in \mathfrak{M} , and $\rho_M^C : M \rightarrow M \otimes C$ is a morphism in \mathfrak{M} , called *right C -coaction*. The right C -coaction is required to satisfy the commutativity of the following diagrams:

$$\begin{array}{ccc}
M \otimes C & \xrightarrow{M \otimes \Delta_C} & M \otimes C \otimes C \\
\uparrow \rho_M^C & & \uparrow \rho_M^C \\
M & \xrightarrow{\rho_M^C} & M \otimes C
\end{array} , \quad
\begin{array}{ccc}
M \otimes C & \xrightarrow{M \otimes \varepsilon_C} & M \\
\uparrow \rho_M^C & \nearrow = & \\
M & &
\end{array} .$$

A *morphism of right C -comodules* is a morphism $f : M \rightarrow M'$ such that the following diagram commute:

$$\begin{array}{ccc}
M \otimes C & \xrightarrow{f \otimes C} & M' \otimes C \\
\uparrow \rho_M^C & & \uparrow \rho_{M'}^C \\
M & \xrightarrow{f} & M'
\end{array} .$$

The category, which has right C -comodules as its objects and right C -comodule morphisms as morphisms, is called *the category of right C -comodules* and it is denoted by \mathcal{M}^C . Combining these two categories, the category of C -bicomodules, or C -comodules for short, can be constructed. The objects are triples $(M, {}^C\rho_M, \rho_M^C)$, where $(M, {}^C\rho_M)$ is a left C -comodule and (M, ρ_M^C) is a right C -comodule, such that the following compatibility condition is fulfilled:

$$\begin{array}{ccc}
C \otimes M & \xrightarrow{C \otimes \rho_M^C} & C \otimes M \otimes C \\
\uparrow c_{\rho_M} & & \uparrow c_{\rho_M \otimes C} \\
M & \xrightarrow{\rho_M^C} & M \otimes C
\end{array} .$$

The morphisms of this category are morphisms $f : M \longrightarrow M'$ in \mathfrak{M} , such that it is a left and right C -comodule morphism. This category is denoted by ${}^C\mathcal{M}^C$. Note that a comonoid $(C, \Delta_C, \varepsilon_C)$ is a C -comodule with coactions (C, Δ_C, Δ_C) .

Consider an object (M, ρ_M^C) in \mathcal{M}^C and an object (N, ρ_N^C) in ${}^C\mathcal{M}$. If the following equalizer exists:

$$M \square_C N \longrightarrow M \otimes N \begin{array}{c} \xrightarrow{M \otimes^C \rho_N} \\ \xrightarrow{\rho_M^C \otimes N} \end{array} M \otimes C \otimes N \quad ,$$

then $M \square_C N$ is called *the cotensor product*.

Let us note that if there exists a morphism of comonoids $f_0 : C \longrightarrow D$, then there exists an induced functor ${}^fF : {}^C\mathcal{M} \longrightarrow {}^D\mathcal{M}$ between categories of left comodules. On objects, fF is defined as ${}^fF(M, \rho_M^C) = (M, (f \otimes M) \cdot \rho_M^C)$, while on morphisms ${}^fF(h) = h$. We write fM for ${}^fF(M, \rho_M^C)$ and fh for ${}^fF(h)$. Similarly, f_0 also induces another functor $F^f : \mathcal{M}^C \longrightarrow \mathcal{M}^D$ between the categories of right comodules. We write M^f for $F^f(M, \rho_M^C)$ and h^f for $F^f(h)$. The combination of fF and F^f gives rise to a functor of categories of comodules ${}^fF^f : {}^C\mathcal{M}^C \longrightarrow {}^D\mathcal{M}^D$.

Finally, if $f_0 : C \longrightarrow D$ is a morphism of comonoids, then for all (M, ρ_M^C) in \mathcal{M}^C and (N, ρ_N^C) in ${}^C\mathcal{M}$, for which $M \square_C N$ and $M^f \square_D {}^fN$ exist, there is a morphism $\iota_f : M \square_C N \longrightarrow M^f \square_D {}^fN$ in \mathfrak{M} induced by the following commutative diagram

$$\begin{array}{ccc} M \square_C N & & \\ \downarrow \text{---} & \searrow & \\ M^f \square_D {}^fN & \longrightarrow & M \otimes N \quad . \end{array} \quad (1.13)$$

Remark on Notation 1.2.2.1. Let M be an object in \mathcal{M}^C , M' an object in ${}^C\mathcal{M}$ and $M \square_C M'$ its cotensor product. Then if $f : N \longrightarrow M \otimes M'$ is a fork for the pair of morphisms $M \otimes^C \rho_{M'}$ and $\rho_M^C \otimes M'$, i.e. $(M \otimes^C \rho_{M'}) \cdot f = (\rho_M^C \otimes M') \cdot f$. Then there exists the following induced map

$$\begin{array}{ccc} N & & \\ \downarrow \text{---} & \searrow f & \\ M \square_C M' & \longrightarrow & M \otimes M' \begin{array}{c} \xrightarrow{M \otimes^C \rho_{M'}} \\ \xrightarrow{\rho_M^C \otimes M'} \end{array} M \otimes C \otimes M' \quad , \end{array}$$

which will be denoted by \tilde{f} .

1.3 Towards Generalization of Internal Categories

Before the definition of an internal category within a monoidal category is given, cf. [2], we look at small categories as internal categories in **Sets**. Let A_0, A_1 be two objects in **Sets** which are part of an internal graph as in (1.1). Note that every set, in particular A_0 , is a comonoid in a unique way, with comultiplication given by the diagonal morphism $\Delta_{A_0} : A_0 \longrightarrow A_0 \times A_0$, $x \longmapsto (x, x)$ and unit $\varepsilon_{A_0} : A_0 \longrightarrow \{*\}$, the unique map $x \longmapsto *$.

A morphism $d : A_1 \longrightarrow A_0$ induces a unique morphism

$$\begin{aligned} A_1 &\xrightarrow{\bar{d}} A_1 \times A_0 , \\ x &\longmapsto (x, d(x)) . \end{aligned} \tag{1.14}$$

With this morphism A_1 becomes a right A_0 -comodule. Similarly, for $c : A_1 \longrightarrow A_0$ there exists $\bar{c} : A_1 \longrightarrow A_0 \times A_1$, $x \longmapsto (c(x), x)$, making A_1 a left A_0 -comodule. Thus (A_1, \bar{c}, \bar{d}) is an A_0 -comodule. With these two morphisms, the requirements (1.2), on d and c , are equivalent to the following requirements for \bar{d} and \bar{c} :

$$\bar{d} \cdot i = (i \times A_0) \cdot \Delta_{A_0} , \tag{1.15a}$$

$$\bar{c} \cdot i = (A_0 \times i) \cdot \Delta_{A_0} . \tag{1.15b}$$

This means that i is a morphism of A_0 -comodules.

The process of transforming requirements for c and d into requirements for \bar{c} and \bar{d} consists in taking appropriate inclusions into cartesian products. In case one wants to recover the original requirements out of the transformed ones, one can use suitable projections over the aforementioned cartesian products.

Next, it is important and convenient to observe that $A_1 \square_{A_0} A_1 \cong A_1 \times_{A_0} A_1$ in **Sets**, where $A_1 \square_{A_0} A_1$ is the equalizer of the parallel morphisms $(A_1 \times \bar{c}, \bar{d} \times A_1)$, the *cotensor product* of comodules (A_1, \bar{d}) and (A_1, \bar{c}) . With this isomorphism, the requirements given by (1.4) are equivalent to the following ones:

$$\bar{c} \cdot m = (A_0 \times m) \cdot (\bar{c} \square_{A_0} A_1) , \tag{1.16a}$$

$$\bar{d} \cdot m = (m \times A_0) \cdot (A_1 \square_{A_0} \bar{d}) . \tag{1.16b}$$

It can be concluded that these equations, (1.16), describe a morphism $m_{A_1} : A_1 \square_{A_0} A_1 \longrightarrow A_1$ in ${}^{A_0}\mathcal{M}^{A_0}$ and equations (1.15) describe a morphism $i : A_0 \longrightarrow A_1$ in ${}^{A_0}\mathcal{M}^{A_0}$ as well.

Finally, the requirements given by (1.6) and (1.5) are equivalent to the following commutative diagrams:

$$\begin{array}{ccc}
 A_1 \square_{A_0} A_1 \square_{A_0} A_1 & \xrightarrow{A_1 \square_{A_0} m} & A_1 \square_{A_0} A_1 \\
 \downarrow m \square_{A_0} A_1 & & \downarrow m \\
 A_1 \square_{A_0} A_1 & \xrightarrow{m} & A_1
 \end{array} , \quad
 \begin{array}{ccc}
 A_1 & \xrightarrow{(A_1 \square_{A_0} i) \cdot \bar{d}} & A_1 \square_{A_0} A_1 \\
 \downarrow (i \square_{A_0} A_1) \cdot \bar{c} & \searrow = & \downarrow m \\
 A_1 \square_{A_0} A_1 & \xrightarrow{m} & A_1
 \end{array} , \quad (1.17)$$

respectively. The morphisms $\bar{c} : A_1 \longrightarrow A_0 \square_{A_0} A_1$ and $\bar{d} : A_1 \longrightarrow A_1 \square_{A_0} A_0$ are corestrictions of \bar{c} and \bar{d} , respectively.

For the functors between internal categories, the equations in (1.7a,b) can be rewritten equivalently for the maps \bar{d} and \bar{c} , as

$$\bar{d}_b \cdot F_1 = (F_1 \times F_0) \cdot \bar{d}_a , \quad (1.18a)$$

$$\bar{c}_b \cdot F_1 = (F_0 \times F_1) \cdot \bar{c}_a . \quad (1.18b)$$

Equations (1.8) and (1.7c) are translated, respectively, into the following commutative diagrams:

$$\begin{array}{ccc}
 A_1 \square_{A_0} A_1 & \xrightarrow{F_1 \square_{F_0} F_1} & B_1 \square_{B_0} B_1 \\
 \downarrow m_a & & \downarrow m_b \\
 A_1 & \xrightarrow{F_1} & B_1
 \end{array} , \quad
 \begin{array}{ccc}
 A_0 & \xrightarrow{F_0} & B_0 \\
 \downarrow i_a & & \downarrow i_b \\
 A_1 & \xrightarrow{F_1} & B_1
 \end{array} . \quad (1.19)$$

The requirements for a natural transformation, expressed by equation (1.9), are equivalent to the following equations:

$$\bar{d}_b \cdot \alpha = (B_0 \times \alpha) \cdot (F_0 \times A_0) \cdot \Delta_{A_0} , \quad (1.20a)$$

$$\bar{c}_b \cdot \alpha = (\alpha \times B_0) \cdot (A_0 \times G_0) \cdot \Delta_{A_0} . \quad (1.20b)$$

The equality $m_b(\alpha \cdot c_a; F_1) = m_b(G_1; \alpha \cdot d_a)$ translates into

$$m_b((\alpha \square_{B_0} F_1) \cdot \bar{c}) = m_b((G_1 \square_{B_0} \alpha) \cdot \bar{d}) , \quad (1.21)$$

The composition between natural transformations can be defined through coequalizers as

$$\beta \circ \alpha = m_b \cdot (\alpha \square_{B_0} \beta) . \quad (1.22)$$

The translation of the proposition (1.1.1) will not be done yet, since the generalization can go further in the next section.

1.4 Internal Categories in a Monoidal Category

In this section several definitions are given which will make some resonance with the requirements for an internal category in $(\mathbf{Sets}, \times, *)$ and which constitute the generalization of an internal category in a monoidal category. This generalization was introduced in [2].

In Section (1.3), it was observed how the monoidal structure of the category of sets can be used to reformulate the notion of an internal category. In particular, the pullbacks can be replaced by particular equalizers that define cotensor products. Furthermore, the pullbacks commute with the cartesian product. Therefore, in order to formulate the definition of an internal category inside a monoidal category $(\mathfrak{M}, \otimes, I)$, it is convenient to require that $(\mathfrak{M}, \otimes, I)$ satisfies the following properties :

- i) \mathfrak{M} has equalizers (E, e) for all parallel morphisms $f \parallel g$, *i.e.*

$$E \xrightarrow{e} A \begin{array}{c} \xrightarrow{f} \\ \xrightarrow{g} \end{array} B ,$$

in particular, those of the form,

$$M \square_C N \longrightarrow M \otimes N \begin{array}{c} \xrightarrow{M \otimes C \rho_N} \\ \xrightarrow{\rho_M^C \otimes N} \end{array} M \otimes C \otimes N .$$

The equalizer (E, e) can also be denoted by $\text{Eq}(f, g)$.

- ii) These equalizers are invariant under the tensor product in \mathfrak{M} , *i.e.*, the following morphism, that always exists, must be an isomorphism

$$X \otimes \text{Eq}(f, g) \otimes Y \xrightarrow{\cong} \text{Eq}(X \otimes f \otimes Y, X \otimes g \otimes Y) .$$

In particular, the following is an isomorphism

$$X \otimes (M \square_C N) \otimes Y \xrightarrow{\cong} (X \otimes M) \square_C (N \otimes Y) .$$

With the two previous assumptions, ${}^C\mathcal{M}^C$ can be made into a monoidal category, $({}^C\mathcal{M}^C, \square_C, C)$, and the following coactions can be constructed ${}^C\rho_M \square_C N := {}^C\rho_M \square_C N$ and $\rho_{M \square_C N}^C := M \square_C \rho_N^C$.

At this moment, it is important to introduce the following category. Since $({}^C\mathcal{M}^C, \square_C, C)$ is a monoidal category, the category $\mathbf{Mon}_{{}^C\mathcal{M}^C}$ of monoids in ${}^C\mathcal{M}^C$ can be constructed. The objects of this category are triples (A, m_A, u_A) , where A is an object in ${}^C\mathcal{M}^C$, $m_A : A \square_C A \rightarrow A$ and $u_A : C \rightarrow A$ are morphisms in ${}^C\mathcal{M}^C$ called *multiplication* and *unit*, respectively. These are required to fulfill the commutativity of the following diagrams

$$\begin{array}{ccc}
 A \square_C A \square_C A & \xrightarrow{A \square_C m_A} & A \square_C A \\
 \downarrow m_A \square_C A & & \downarrow m_A \\
 A \square_C A & \xrightarrow{m_A} & A
 \end{array}
 , \quad
 \begin{array}{ccc}
 A & \xrightarrow{A \square_C u_A} & A \square_C A \\
 \downarrow u_A \square_C A & \searrow = & \downarrow m_A \\
 A \square_C A & \xrightarrow{m_A} & A
 \end{array}
 .$$

Morphisms $f : (A, m_A, u_A) \rightarrow (B, m_B, u_B)$ in $\mathbf{Mon}_{{}^C\mathcal{M}^C}$ are morphisms $f : A \rightarrow B$ in ${}^C\mathcal{M}^C$ such that ,

$$\begin{array}{ccc}
 A \square_C A & \xrightarrow{f \square_C f} & B \square_C B \\
 \downarrow m_A & & \downarrow m_B \\
 A & \xrightarrow{f} & B
 \end{array}
 , \quad
 \begin{array}{ccc}
 & C & \\
 u_A \swarrow & & \searrow u_B \\
 A & \xrightarrow{f} & B
 \end{array}
 ,$$

commute.

In the case of an internal category (A_0, A_1, c, d, i, m) in **Sets**, the diagrams in (1.17) describe a monoid (A_1, m, i) in ${}^{A_0}\mathcal{M}^{A_0}$. Due to this observation, $((A, m_A, u_A), {}^C\rho_A, \rho_A^C, C)$ will be the generalization of $((A_1, m, i), \bar{c}, \bar{d}, A_0)$, as an internal category inside a monoidal one.

In what follows every object (A, m_A, u_A) in $\mathbf{Mon}_{{}^C\mathcal{M}^C}$ will be called an *internal category* in $(\mathfrak{M}, \otimes, I)$. The object C will be called *the object of objects* and A *the object of morphisms*, to simplify the notation we write (A, C) with multiplication and coactions left out.

Note 1.4.1. In [7], the author define the concept of an *internal ${}^C\mathcal{M}$ -valued functor*, $\chi : (A, C) \rightarrow {}^C\mathcal{M}$ as a left A -module M in ${}_A\mathcal{M}$. On the other hand, a natural transformation between internal ${}^C\mathcal{M}$ -valued functors, $h : \chi \rightarrow \chi'$ is defined as a morphism $h : M \rightarrow M'$ of left A -modules.

Consider, on the other hand, the "dual" internal category \mathcal{I}^* , which is obtained from the internal graph (1.1) by interchanging the roles of c and d , which in turn, gives a twisted composition in (1.3). If the construction of an internal monoidal category is based on this "dual" internal category, the concept corresponding to the a internal valued functor is that of a right A -module M and it is termed in this way as an *internal presheaf*.

1.4.1 Examples of Internal Categories

-) In the monoidal category $(\mathbf{Vect}, \otimes, k)$, the internal categories are C -rings or C -semialgebras.

The category of comonoids $\mathbf{Comon}_{\mathbf{Vect}}$ is usually referred to as the category of *coalgebras*. The construction for internal categories within this monoidal category follows in the same lines as in the previous sections. For each coalgebra $(C, \Delta_C, \varepsilon_C)$, one can construct the category of comodules ${}^C\mathcal{M}^C$, this last category can be given the structure of a monoidal category $({}^C\mathcal{M}^C, \square_C, C)$, see [29]. Then the internal categories are monoids in ${}^C\mathcal{M}^C$ which are called C -rings or C -semialgebras, see [9].

-) In the monoidal category $(\mathbf{Mod}_R^{op}, \otimes_R, R)$, the internal categories are corings.

We explain the second example in a more explicit way. In Section 1.2.1 was pointed out that the opposite category of a monoidal category inherits the same monoidal structure. Then $\mathbf{Comon}_{\mathbf{Mod}_R^{op}} = \mathbf{Mon}_{\mathbf{Mod}_R} = \mathbf{Alg}_R$, the category of algebras over a commutative ring, see [1]. An object in \mathbf{Alg}_R is denoted by (A, m_A, u_A) .

In this case, the category of C -comodules over \mathbf{Mod}_R^{op} , ${}^C(\mathbf{Mod}_R^{op})^C$ is seen as the category of A -modules over \mathbf{Mod}_R , denoted by ${}_A(\mathbf{Mod}_R)_A$ or by ${}_A\mathcal{M}_A$. The category ${}_A(\mathbf{Mod}_R)_A$ consists of objects $(N, {}^A\chi_N, \chi_N^A)$, where N is an object in \mathbf{Mod}_R and ${}^A\chi_N : A \otimes N \rightarrow N$, $\chi_N^A : N \otimes A \rightarrow N$ are morphisms in \mathbf{Mod}_R such that they fulfill the requirements for a comodule in Section 1.2.2, but with the arrows of the diagrams inverted. A morphism $f : (N, {}^A\chi_N, \chi_N^A) \rightarrow (N', {}^A\chi_{N'}, \chi_{N'}^A)$ in ${}_A(\mathbf{Mod}_R)_A$, is a morphism $f : N \rightarrow N'$ in \mathbf{Mod}_R such that fulfills also the requirements in Section 1.2.2, but with the arrows of the diagrams inverted.

The category \mathbf{Mod}_R^{op} has equalizers and these equalizers are preserved by the tensor product, as can be seen in the following dual

Proposition 1.4.1.1. *The category \mathbf{Mod}_R has coequalizers and these coequalizers are preserved by the tensor product.*

Proof:

Let $f, g : M \rightarrow N$ be a pair of a parallel arrows, then the coequalizer of (f, g) is the following module,

$$M \begin{array}{c} \xrightarrow{f} \\ \xrightarrow{g} \end{array} \rightrightarrows N \xrightarrow{q} Q := N / \langle f(x) - g(x); x \in M \rangle .$$

In order to show that the the second requirement is fulfilled, the previous coequalizer can be written, in an equivalent way, as the following right exact sequence:

$$M \xrightarrow{f-g} N \longrightarrow Q \longrightarrow 0 .$$

Since the functors $B \otimes _$ and $_ \otimes C$ are right-exact functors [29], it follows that $B \otimes Q \otimes C$ is the coequalizer of the parallel arrows $(B \otimes f \otimes C, B \otimes g \otimes C)$ as required. \square

Let (A, m_A, u_A) be an algebra in \mathbf{Alg}_R . Then the monoidal category $({}_A(\mathbf{Mod}_R)_A, \otimes_A, A)$ can be constructed according to [2]. Therefore, a comonoid $(C, \Delta_C, \varepsilon_C)$ in the category ${}_A(\mathbf{Mod}_R)_A$, is an internal category in \mathbf{Mod}_R^{op} . The definition of an internal category in \mathbf{Mod}_R^{op} coincides with the definition of a coring, see [12].

1.4.2 Internal Functors and Natural Transformations

Next, functors between internal categories are defined. This definition should be compared with (1.18) and (1.19).

Definition 1.4.2.1. A functor $f : (A, C) \longrightarrow (B, D)$ between internal categories is a pair $f = (f_1, f_0)$, where

i) $f_0 : C \longrightarrow D$ is a morphism in $\mathbf{Comon}_{\mathfrak{M}}$,

ii) $f_1 : A \longrightarrow B$ is a morphism in \mathfrak{M} that is also a morphism of D -bicomodules, $f_1 : {}^f A^f \longrightarrow B$.

iii) the following diagrams commute:

$$\begin{array}{ccc} A \square_C A & \xrightarrow{\iota_f} & A^f \square_D A^f & \xrightarrow{f_1 \square_D f_1} & B \square_D B \\ m_A \downarrow & & & & \downarrow m_B \\ A & \xrightarrow{f_1} & B & & \end{array}, \quad \begin{array}{ccc} C & \xrightarrow{f_0} & D \\ u_A \downarrow & & \downarrow u_B \\ A & \xrightarrow{f_1} & B \end{array} .$$

Definition 1.4.2.2. Let $f, g : (A, C) \longrightarrow (B, D)$ be internal functors. An internal natural transformation $\alpha : f \longrightarrow g : (A, C) \longrightarrow (B, D)$ is a morphism $\alpha : {}^g C^f \longrightarrow B$ of D -bicomodules making the following diagram commute

$$\begin{array}{ccccc} & & A \square_C C & \xrightarrow{\iota_g} & A^g \square_D A^g & \xrightarrow{g_1 \square_D \alpha} & B \square_D B & & \\ & \nearrow \tilde{\rho}_A^C & & & & & \downarrow m_B & & \\ A & & & & & & & & B \\ & \searrow {}^C \tilde{\rho}_A & C \square_C A & \xrightarrow{\iota_f} & C^f \square_D A^f & \xrightarrow{\alpha \square_D f_1} & B \square_D B & & \\ & & & & & & \downarrow m_B & & \end{array},$$

The category constructed with internal categories in $(\mathfrak{M}, \otimes, I)$ as objects and internal functors as morphisms is denoted by $\mathbf{IntCat}(\mathfrak{M})$.

1.5 2-Categories

1.5.1 Definition of 2-Categories

The aim of this section is to describe two different ways in which internal categories in $(\mathfrak{M}, \otimes, I)$ can be made into a 2-category. We begin by recalling the definition of a 2-category; see [2], [23] and [26]. The datum that forms a 2-category is $\mathcal{A} = (\mathcal{A}_0, \mathcal{A}_1, \mathcal{A}_2, \cdot, \circ, \bar{*})$, where

i) \mathcal{A}_0 is the collection of 0-cells, depicted as

$$A, B, C, \dots$$

ii) \mathcal{A}_1 is the collection of 1-cells, depicted as

$$A \xrightarrow{f} B, B \xrightarrow{h} C, \dots$$

iii) \mathcal{A}_2 is the collection of 2-cells, depicted as

$$A \begin{array}{c} \xrightarrow{f} \\ \downarrow \alpha \\ \xrightarrow{g} \end{array} B, B \begin{array}{c} \xrightarrow{h} \\ \downarrow \gamma \\ \xrightarrow{k} \end{array} C, \dots$$

i') $(\mathcal{A}_0, \mathcal{A}_1, \cdot)$ is a category, with composition depicted as

$$A \xrightarrow{f} B \xrightarrow{h} C = A \xrightarrow{h \cdot f} C,$$

and the unit of A in \mathcal{A}_0 for this composition is

$$A \xrightarrow{1_A} A.$$

This category will be referred to as the *underlying category* of the 2-category \mathcal{A} .

ii') For all 0-cells A, B , $(\mathcal{A}_1(A, B), \mathcal{A}_2(A, B), \circ)$ is a category, with composition depicted as

$$A \begin{array}{c} \xrightarrow{f} \\ \downarrow \alpha \\ \xrightarrow{g} \end{array} B = A \begin{array}{c} \xrightarrow{f} \\ \downarrow \beta \circ \alpha \\ \xrightarrow{g} \end{array} B,$$

and the unit of $f : A \longrightarrow B$ in $\mathcal{A}_1(A, B)$, for this composition is

$$A \begin{array}{c} \xrightarrow{f} \\ \downarrow 1_f \\ \xrightarrow{f} \end{array} B \quad .$$

The composition $\circ : \mathcal{A}_2 \times \mathcal{A}_2 \longrightarrow \mathcal{A}_2$ will be referred to as the *vertical composition*. Along this thesis, the category $(\mathcal{A}_1(A, B), \mathcal{A}_2(A, B), \circ)$ will also be denoted by $\text{Hom}_{\mathcal{A}}(A, B)$ or $\mathcal{A}(A, B)$.

iii') $(\mathcal{A}_0, \mathcal{A}_2, \bar{*})$ is a category, with composition depicted as

$$A \begin{array}{c} \xrightarrow{f} \\ \downarrow \alpha \\ \xrightarrow{g} \end{array} B \begin{array}{c} \xrightarrow{h} \\ \downarrow \gamma \\ \xrightarrow{k} \end{array} C = A \begin{array}{c} \xrightarrow{h \cdot f} \\ \downarrow \gamma \bar{*} \alpha \\ \xrightarrow{k \cdot g} \end{array} C \quad ,$$

and the unit of $A \in \mathcal{A}_0$ under this composition is,

$$A \begin{array}{c} \xrightarrow{1_A} \\ \downarrow 1_{1_A} \\ \xrightarrow{1_A} \end{array} A \quad .$$

The composition $\bar{*} : \mathcal{A}_2 \times \mathcal{A}_2 \longrightarrow \mathcal{A}_2$ will be referred to as the *horizontal composition*.

The vertical and horizontal composition are required to satisfy two compatibility conditions:

1. Compatibility with the unital natural transformation,

$$A \begin{array}{c} \xrightarrow{f} \\ \downarrow 1_f \\ \xrightarrow{f} \end{array} B \begin{array}{c} \xrightarrow{h} \\ \downarrow 1_h \\ \xrightarrow{h} \end{array} C = A \begin{array}{c} \xrightarrow{h \cdot f} \\ \downarrow 1_h \bar{*} 1_f \\ \xrightarrow{h \cdot f} \end{array} C \stackrel{!}{=} A \begin{array}{c} \xrightarrow{h \cdot f} \\ \downarrow 1_{h \cdot f} \\ \xrightarrow{h \cdot f} \end{array} C \quad .$$

2. The interchange law,

$$\begin{array}{ccc}
\begin{array}{ccc}
A & \xrightarrow{f} & B \\
\downarrow \alpha & & \downarrow \gamma \\
A & \xrightarrow{\beta} & B \\
\downarrow \beta & & \downarrow \delta \\
A & \xrightarrow{g} & B \\
& & \downarrow \delta \\
& & C
\end{array}
& \xrightarrow{h} &
\begin{array}{ccc}
B & \xrightarrow{h} & C \\
\downarrow \gamma & & \downarrow \delta \\
B & \xrightarrow{\delta} & C \\
\downarrow \delta & & \downarrow \delta \\
B & \xrightarrow{k} & C \\
& & \downarrow \delta \\
& & C
\end{array}
& = &
\begin{array}{ccc}
A & \xrightarrow{h \cdot f} & C \\
\downarrow (\delta \circ \gamma) \bar{*} (\beta \circ \alpha) & & \downarrow (\delta \bar{*} \beta) \circ (\gamma \bar{*} \alpha) \\
A & \xrightarrow{g \cdot k} & C
\end{array}
& \stackrel{!}{=} &
\begin{array}{ccc}
A & \xrightarrow{h \cdot f} & C \\
\downarrow (\delta \bar{*} \beta) \circ (\gamma \bar{*} \alpha) & & \downarrow (\delta \bar{*} \beta) \circ (\gamma \bar{*} \alpha) \\
A & \xrightarrow{g \cdot k} & C
\end{array}
.
\end{array}$$

2-categories admit more duals than ordinary categories. By reversing all 1-cells in \mathcal{A} one obtains the opposite 2-category \mathcal{A}^{op} . By reversing 2-cells one arrives at the 2-category denoted by \mathcal{A}^{co} . Finally, combining these two operations, one obtains $\mathcal{A}^{co\,op} = \mathcal{A}^{op\,co}$, the 2-category with the same 0-cells as in \mathcal{A} but with 1-cells and 2-cells reversed.

Remark 1.5.1.1. Given a 2-category \mathcal{A} with one object A . There exists a monoidal category, $(Hom_{\mathcal{A}}(A, A), \bar{*}, 1_{1_A})$, where $Hom_{\mathcal{A}}(A, A)$ is the category formed by the 1-cells of the type $f : A \rightarrow A$.

1.5.2 Examples of 2-Categories

- 1- The prototype example of a 2-category is the category ${}_2\mathbf{Cat}$ whose 0-cells are categories, 1-cells are functors and 2-cells are natural transformations. The vertical structure is given by the composition of natural transformations and the horizontal one is given by the usual Godement product. This Godement product is defined as follows, let $\alpha : F \rightarrow G : \mathcal{C} \rightarrow \mathcal{D}$ and $\beta : H \rightarrow K : \mathcal{C} \rightarrow \mathcal{D}$ be natural transformations or 2-cells in ${}_2\mathbf{Cat}$, then the Godement product of these two natural transformations, usually denoted by $\beta * \alpha$ instead of $\beta \bar{*} \alpha$, is defined as

$$(\beta * \alpha)_C = \beta_{GC} \cdot H\alpha_C = K\alpha_C \cdot \beta_{FC} . \quad (1.23)$$

This last equality is called Godement product equality.

Note 1.5.1. Let $\alpha : F \rightarrow G : \mathcal{C} \rightarrow \mathcal{D}$ be a natural transformation in ${}_2\mathbf{Cat}$, then for any morphism $f : A \rightarrow A'$ in the category \mathcal{C} , the following diagram commutes

$$\begin{array}{ccc}
FA & \xrightarrow{Ff} & FA' \\
\downarrow \alpha_A & & \downarrow \alpha_{A'} \\
GA & \xrightarrow{Gf} & GA'
\end{array} ,$$

i.e. $\alpha_{A'} \cdot Ff = Gf \cdot \alpha_A$. This equality will be referred to as *the naturality of α applied over f* or just simply the naturality of α over f . This statement proves to be useful when argumenting.

- 2- The 2-category of 2-categories, denoted by 2-Cat . The 0-cells in 2-Cat are 2-categories \mathcal{A}, \mathcal{B} , etc. The 1-cells are 2-functors, *i.e.* operations $F : \mathcal{A} \rightarrow \mathcal{B}$ which send n -cells to n -cells and are compatible with the compositions and units in \mathcal{A} and \mathcal{B} . The 2-cells are 2-natural transformations. Given 2-functors $F, G : \mathcal{A} \rightarrow \mathcal{B}$ a 2-natural transformation $\alpha : F \rightarrow G$ sends 0-cells in \mathcal{A} to 1-cells in \mathcal{B} and satisfies the following property. For any 2-cell $\gamma : f \rightarrow g$ in \mathcal{A} ,

$$\begin{array}{ccc}
 & Ff & \\
 FA & \begin{array}{c} \curvearrowright \\ \downarrow F\gamma \\ \curvearrowleft \end{array} & FB \xrightarrow{\alpha B} GB \\
 & Fg & \\
 \end{array} = \begin{array}{ccc}
 & Gf & \\
 FA \xrightarrow{\alpha A} GA & \begin{array}{c} \curvearrowright \\ \downarrow G\gamma \\ \curvearrowleft \end{array} & GB \\
 & Gg & \\
 \end{array} ,$$

i.e.

$$\begin{array}{ccc}
 & \alpha_B \cdot Ff & \\
 FA & \begin{array}{c} \curvearrowright \\ \downarrow 1_{\alpha_B} \bar{*} F\gamma \\ \curvearrowleft \end{array} & GB \\
 & \alpha_B \cdot Fg & \\
 \end{array} = \begin{array}{ccc}
 & Gf \cdot \alpha_A & \\
 FA & \begin{array}{c} \curvearrowright \\ \downarrow G\gamma \bar{*} 1_{\alpha_A} \\ \curvearrowleft \end{array} & GB \\
 & Gg \cdot \alpha_A & \\
 \end{array} ; \tag{1.24}$$

see [26]. Note that condition (1.24) includes the standard requirement $\alpha_B \cdot Ff = Gf \cdot \alpha_A$ on the underlying category $(\mathcal{A}_0, \mathcal{A}_1, \cdot)$.

At this point it is convenient to make the following observation. In the usual category theory if a natural transformation is invertible, then its inverse is necessarily a natural transformation. The same is true for 2-natural transformations, and this is proved by similar methods as in the standard category theory.

- 3- There exists a very closed related concept to a 2-category, that of a *bicategory*, see [5] and [23]. A bicategory is the same as a 2-category, but is such that for each triple

$$A \xrightarrow{f} B \xrightarrow{g} C \xrightarrow{h} D,$$

There exists isomorphic 2-cells

$$\begin{array}{ccc}
 & h \cdot (g \cdot f) & \\
 A & \begin{array}{c} \curvearrowright \\ \downarrow \alpha_{h,g,f} \\ \curvearrowleft \end{array} & B \\
 & (h \cdot g) \cdot f & \\
 \end{array} ,$$

which are natural in f, g, h . These 2-cells are called *associativity coherence isomorphisms*. There exists also another two isomorphic 2-cells, for any 1-cell $f : A \rightarrow B$,

$$\begin{array}{ccc}
 & 1_B \cdot f & \\
 & \curvearrowright & \\
 A & \downarrow \lambda_f & B , \\
 & \curvearrowleft & \\
 & f &
 \end{array}
 , \quad
 \begin{array}{ccc}
 & f \cdot 1_A & \\
 & \curvearrowright & \\
 A & \downarrow \rho_f & B , \\
 & \curvearrowleft & \\
 & f &
 \end{array}$$

these 2-cells are also required to be natural in f . These 2-cells are called *unit coherence isomorphisms*. These three 2-cells are required to satisfy similar commutative diagrams like in (1.10).

The next bicategory is of particular interest in this thesis. Its construction relies on Section 1.2.2. The construction of this bicategory needs a monoidal category $(\mathfrak{M}, \otimes, I)$ with equalizers that are preserved by \otimes . Then the 0-cells of this bicategory are the comonoids in \mathfrak{M} , namely $(C, \Delta_C, \varepsilon_C)$ as in Section 1.2.2. When writing the 2 diagrams for this bicategory the comultiplication Δ_C and the counit ε_C are left understood in order to avoid complicated diagrams. The 1-cells for this bicategory

$$\begin{array}{ccc}
 & M & \\
 & \curvearrowright & \\
 C & & D , \\
 & &
 \end{array}$$

are bicomodules $(M, {}^C\rho_M, \rho_M^D)$ in ${}^C\mathcal{M}^D$. The 2-cells of this bicategory

$$\begin{array}{ccc}
 & M & \\
 & \curvearrowright & \\
 C & \downarrow f & D , \\
 & \curvearrowleft & \\
 & N &
 \end{array}$$

are morphisms of bicomodules $f : M \rightarrow N$ in ${}^C\mathcal{M}^D$. The composition for the underlying category is defined by the cotensor product of comodules, *i.e.*

$$\begin{array}{ccc}
 & M & & N & \\
 & \curvearrowright & & \curvearrowright & \\
 C & & C' & & C'' = C & & C'' , \\
 & & & & \curvearrowright & & \\
 & & & & M \square_{C'} N & &
 \end{array}$$

and the unit of $(C, \Delta_C, \varepsilon_C)$ for this composition is (C, Δ_C, Δ_C) . For the vertical structure, the composition is defined through the following 2-diagram

$$\begin{array}{ccc}
 & M & \\
 & \downarrow & \\
 C & \xrightarrow{f} & D \\
 & \downarrow & \\
 & M'' & \\
 & \downarrow & \\
 C & \xrightarrow{g} & D \\
 & \downarrow & \\
 & M'' &
 \end{array}
 =
 \begin{array}{ccc}
 & M & \\
 & \downarrow & \\
 C & \xrightarrow{g \cdot f} & D \\
 & \downarrow & \\
 & M'' &
 \end{array}
 ,$$

and the unit of (M, ρ_M, ρ_M^D) for this composition is just $1_M : M \longrightarrow M$. For the horizontal structure, the composition is defined through the following 2-diagram

$$\begin{array}{ccc}
 \begin{array}{ccc}
 \begin{array}{ccc}
 C & \xrightarrow{M} & C' \\
 \downarrow f & & \downarrow g \\
 N & \xrightarrow{N'} & N'
 \end{array} & & \\
 \begin{array}{ccc}
 C & \xrightarrow{M'} & C'' \\
 \downarrow g & & \downarrow g \\
 N' & \xrightarrow{N''} & N''
 \end{array} & = & \\
 \begin{array}{ccc}
 C & \xrightarrow{M \square_{C'} N} & B \\
 \downarrow f \square_{C'} g & & \downarrow f \square_{C'} g \\
 M' \square_{C'} N' & \xrightarrow{M' \square_{C'} N'} & B
 \end{array}
 \end{array}
 \end{array}
 ,$$

and the unit of $(C, \Delta_C, \varepsilon_C)$ for this composition is $1_C : C \longrightarrow C$.

1.5.3 $\mathbf{IntCat}(\mathfrak{M})$ as a 2-category

The aim of this section is to equip $\mathbf{IntCat}(\mathfrak{M})$ with the structure of a 2-category, whose 0-cells are internal categories in \mathfrak{M} , 1-cells are internal functors and 2-cells are internal natural transformations.

In order to give a horizontal and vertical structure to \mathbf{IntCat} , let us start by giving the following definition for a vertical composition for 2-cells. In the case of the following 2-cell diagram,

$$\begin{array}{ccc}
 & f & \\
 & \downarrow \alpha & \\
 (A, C) & \xrightarrow{r} & (B, D) \\
 & \downarrow \beta & \\
 & g &
 \end{array}
 .$$

The vertical composition \circ

$$\begin{array}{ccc}
 & f & \\
 & \downarrow \beta * \alpha & \\
 (A, C) & \xrightarrow{r} & (B, D) \\
 & \downarrow g &
 \end{array}
 ,$$

is defined as

$$\beta * \alpha = C \xrightarrow{\tilde{\Delta}_C} C \square_C C \xrightarrow{\iota_r} C^r \square_D^r C \xrightarrow{\beta \square_D \alpha} B \square_D B \xrightarrow{m_B} B . \quad (1.25)$$

The unit of $f : (A, C) \longrightarrow (B, D)$, for this vertical product, is $u_B f_0$. The notation for the vertical composition of 2-cells is not the usual one, \circ , because there is already a very well known and used notation for this composition, called *convolution product*, and it is $*$.

Before we give the definition of the horizontal product, note that in the following 2-cell diagram in $\mathbf{IntCat}(\mathfrak{M})$,

$$(A', C') \xrightarrow{h} (A, C) \begin{array}{c} \xrightarrow{f} \\ \downarrow \alpha \\ \xrightarrow{g} \end{array} (B, D) \xrightarrow{k} (B', D') \quad , \quad (1.26)$$

both $k_1\alpha$ and αh_0 are natural transformations.

With this observation at hand, consider the following 2-cell diagram in $\mathbf{IntCat}(\mathfrak{M})$:

$$(A, C) \begin{array}{c} \xrightarrow{f} \\ \downarrow \alpha \\ \xrightarrow{g} \end{array} (E, F) \begin{array}{c} \xrightarrow{h} \\ \downarrow \beta \\ \xrightarrow{k} \end{array} (B, D) \quad . \quad (1.27)$$

The horizontal product or the *Godement product* $\beta\bar{*}\alpha$ of the natural transformations α and β

$$(A, C) \begin{array}{c} \xrightarrow{h \cdot f} \\ \downarrow \beta\bar{*}\alpha \\ \xrightarrow{k \cdot g} \end{array} (B, D) \quad ,$$

is defined as,

$$\beta\bar{*}\alpha = \beta g_0 * h_1\alpha = k_1\alpha * \beta f_0 . \quad (1.28)$$

This last equality will be called the *Godement product equality*. The Godement product is well-defined because of the proof of the following

Proposition 1.5.3.1. *Consider the diagram in (1.27), the Godement product of internal natural transformations α, β is well defined.*

Proof:

That the Godement product is a natural transformation is clear from the note on (1.26), the only thing to prove is the unambiguity of the definition through the equality.

If the factorization Lemma A.2 is applied to the convolution products $\beta g_0 * h_1\alpha = m_B \cdot (\beta g_0 \square_D h_1\alpha) \cdot \iota_{hg} \cdot \tilde{\Delta}_C$ and $k_1\alpha * \beta f_0 = m_B \cdot (k_1\alpha \square_D \beta f_0) \cdot \iota_{kf} \cdot \tilde{\Delta}_C$, then we get the upper and the lower branch of the following diagram, respectively.

$$\begin{array}{ccccccc}
 C \square_C C & \xrightarrow{\iota_g} & C^g \square_F^g C & \xrightarrow{g_0 \square_F \alpha} & F \square_F E & \xrightarrow{\iota_h} & F^h \square_D^h E & \xrightarrow{\beta \square_D h_1} & B \square_D B & \xrightarrow{m_B} & B \\
 \uparrow \tilde{\Delta}_C & & (i) & \nearrow F \tilde{\rho}_E & & & & & & & \\
 C & \xrightarrow{\alpha} & E & & & & & & & & \\
 \downarrow \tilde{\Delta}_C & & (ii) & \searrow \tilde{\rho}_E^F & & & & & & & \\
 C \square_C C & \xrightarrow{\iota_f} & C^f \square_F^f C & \xrightarrow{\alpha \square_F f_0} & F \square_F E & \xrightarrow{\iota_k} & F^k \square_D^k E & \xrightarrow{k_1 \square \beta} & B \square_D B & \xrightarrow{m_B} & B
 \end{array} ,$$

This diagram commutes because

1. The diagram (i) is the induced commutative diagram, according to Lemma A.6, by the left colinearity of α , *i.e.* $F\rho_E \cdot \alpha = (F \otimes \alpha) \cdot (g_0 \otimes C) \cdot \Delta_C$.
2. The diagram (ii) is the induced commutative diagram by the right colinearity of α .
3. The diagram (iii) commutes because β is a natural transformation.

Therefore

$$\beta g_0 * h_1 \alpha = k_1 \alpha * \beta f_0,$$

as required. \square

The unit for the horizontal product of the internal category (A, C) is u_A .

Next we state, without proof, the following

Lemma 1.5.3.2. *Consider the following 2-diagram in $\mathbf{IntCat}(\mathfrak{M})$*

$$\begin{array}{ccccc}
 & & f & & \\
 & & \downarrow \alpha & & \\
 (A', C') & \xrightarrow{h} & (A, C) & \xrightarrow{r} & (B, D) & \xrightarrow{k} & (B', D') & . \\
 & & \downarrow \beta & & \\
 & & g & &
 \end{array}$$

Then $(\beta * \alpha)h_0 = \beta h_0 * \alpha h_0$ and $k_1(\beta * \alpha) = k_1\beta * k_1\alpha$.

With Lemma 1.5.3.2 at hand, take internal natural transformations $\alpha : f \rightarrow g : (A', C') \rightarrow (A, C)$, $\beta : h \rightarrow k : (A, C) \rightarrow (B, D)$ and $\gamma : r \rightarrow s : (B, D) \rightarrow (B', D')$, and compute

$$\begin{aligned}
 \gamma \bar{*}(\beta \bar{*} \alpha) &= \gamma \bar{*}(\beta g_0 * h_1 \alpha) \\
 &= \gamma(k_0 \cdot g_0) * r_1(\beta g_0 * h_1 \alpha) \\
 &= \gamma k_0 g_0 * r_1 \beta g_0 * r_1 h_1 \alpha \\
 &= (\gamma k_0 * r_1 \beta) g_0 * r_1 h_1 \alpha \\
 &= (\gamma \bar{*} \beta) g_0 * r_1 h_1 \alpha \\
 &= (\gamma \bar{*} \beta) \bar{*} \alpha .
 \end{aligned}$$

Along with the aforementioned lemma, the definition of the Godement product and the associativity of the vertical product $*$ were used. This proves the associativity of the horizontal product $\bar{*}$.

Proposition 1.5.3.3. *The vertical and horizontal compositions, $*$ and $\bar{*}$, respectively, defined above satisfy the interchange law.*

Proof:

Consider the following 2-diagram in $\mathbf{IntCat}(\mathfrak{M})$

$$\begin{array}{ccccc}
 & & f & & h \\
 & \curvearrowright & \downarrow \alpha & \curvearrowright & \downarrow \gamma \\
 (A, C) & \xrightarrow{r} & (E, F) & \xrightarrow{s} & (B, D) \\
 & \curvearrowleft & \downarrow \beta & \curvearrowleft & \downarrow \delta \\
 & & g & & k
 \end{array} ,$$

Then

$$\begin{aligned}
 (\delta * \gamma) \bar{*} (\beta * \alpha) &= (\delta * \gamma) g_0 * h_1 (\beta * \alpha) \\
 &= (\delta g_0 * \gamma g_0) * (h_1 \beta * h_1 \alpha) \\
 &= \delta g_0 * (\gamma g_0 * h_1 \beta) * h_1 \alpha \\
 &= \delta g_0 * (s_1 \beta * \gamma r_0) * h_1 \alpha \\
 &= (\delta g_0 * s_1 \beta) * (\gamma r_0 * h_1 \alpha) \\
 &= (\delta \bar{*} \beta) * (\gamma \bar{*} \alpha) .
 \end{aligned}$$

Lemma 1.5.3.2 has been applied several times along with the definition of the Godement product and the associativity of the vertical product. In the fourth equality, the Godement product equality was used for the definition of $\gamma \bar{*} \beta$. \square

Finally, the proof of the compatibility of unital natural transformations with compositions is easy and left to the reader. The results of this section are summarized in the following

Proposition 1.5.3.4. *$\mathbf{IntCat}(\mathfrak{M})$ is a 2-category with 0-cells internal categories, 1-cells internal functors and 2-cells internal natural transformations and vertical and horizontal compositions, $*$ and $\bar{*}$, defined by (1.25) and (1.28), respectively.*

\square

1.5.4 IntCoCat(\mathfrak{M}) as a 2-category

Finally, there exist another definition of functor between internal categories, which is termed *cofunctor*, see [2]. The notion of a cofunctor gives rise to a completely different 2-category **IntCoCat**(\mathfrak{M}), having the internal categories in \mathfrak{M} as its 0-cells. This section is devoted to the description of **IntCoCat**(\mathfrak{M}). Since the 0-cells are the same as in **IntCat**(\mathfrak{M}), we start with the definition of 1-cells

Definition 1.5.4.1. Let (A, C) and (B, D) be internal categories in \mathfrak{M} . A cofunctor $f : (A, C) \longrightarrow (B, D)$ is a pair $f = (f_1, f_0)$,

$$(A, C) \xrightarrow{f = (f_1, f_0)} (B, D) ,$$

where

-) $f_0 : D \longrightarrow C$ is a morphism in $\mathbf{Comon}_{\mathfrak{M}}$,
-) $f_1 : A \square_C {}^f D \longrightarrow {}^f B$ is a morphism in ${}^C \mathcal{M}^D$ such that the following diagrams

$$\begin{array}{ccc} A \square_C A \square_C {}^f D & \xrightarrow{A \square_C f_1} & A \square_C {}^f B \xrightarrow{\cong} A \square_C {}^f D \square_D B \xrightarrow{f_1 \square_D B} & B \square_D B \\ \downarrow m_A \square_C {}^f D & & & \downarrow m_B \\ A \square_C {}^f D & \xrightarrow{f_1} & B \end{array} , \quad \begin{array}{ccc} C \square_C {}^f D & \xleftarrow{\cong} & D \\ \downarrow u_A \square_C {}^f D & & \downarrow u_B \\ A \square_C {}^f D & \xrightarrow{f_1} & B \end{array} .$$

commute.

The definition of a *natural cotransformation*, for the 2-cell structure of **IntCoCat**(\mathfrak{M}), is given on the next:

Definition 1.5.4.2. Let $f, g : (A, C) \longrightarrow (B, D)$ be cofunctors. Then a natural cotransformation α ,

$$(A, C) \begin{array}{c} \xrightarrow{f} \\ \downarrow \alpha \\ \xrightarrow{g} \end{array} (B, D) , \quad (1.29)$$

is a morphism $\alpha : {}^f D \rightarrow {}^g B$ in ${}^C \mathcal{M}^D$ such that the following diagram

$$\begin{array}{ccccc}
& & A \square_C^g B & \xrightarrow{\cong} & A \square_C^g D \square_D B & \xrightarrow{g_1 \square_D B} & B \square_D B & \xrightarrow{m_B} & B \\
& \nearrow^{A \square_C \alpha} & & & & & & & \\
A \square_C^f D & & & & & & & & \\
& \searrow_{f_1} & & & & & & & \\
& & B & \xrightarrow{\cong} & D \square_D B & \xrightarrow{\alpha \square_D B} & B \square_D B & \xrightarrow{m_B} & B
\end{array}$$

commutes.

The composition of 1-cells over the following 1-cell diagram

$$(A, C) \xrightarrow{f} (A', C') \xrightarrow{h} (A'', C'') = (A, C) \xrightarrow{h \cdot f} (A'', C'') ,$$

is defined by

$$\begin{aligned}
(h \cdot f)_0 &= f_0 \cdot h_0 , \\
(h \cdot f)_1 &= h_1 \cdot (f_1 \square_{C'}^h C'') .
\end{aligned}$$

The vertical product over a 2-cell diagram

$$\begin{array}{ccc}
& f & \\
& \downarrow \alpha & \\
(A, C) & \xrightarrow{f'} & (B, D) \\
& \downarrow \beta & \\
& f'' &
\end{array}
=
\begin{array}{ccc}
& f & \\
& \downarrow \beta \circ \alpha & \\
(A, C) & \xrightarrow{f''} & (B, D) \\
& \downarrow & \\
& f'' &
\end{array}$$

is defined by

$$\beta \circ \alpha = m_B \cdot (\beta \square_D B) \cdot {}^D \tilde{\rho}_B \cdot \alpha : D \longrightarrow B .$$

The unit cotransformation of $f : (A, C) \longrightarrow (B, D)$, for this composition, is the unit of (B, D) , $u_B : D \longrightarrow B$. On the other hand, the horizontal structure over a 2-cell diagram

$$\begin{array}{ccccc}
& f & & h & & h \cdot f \\
& \downarrow \alpha & & \downarrow \gamma & & \downarrow \gamma \bar{*} \alpha \\
(A, C) & \xrightarrow{f} & (A', C') & \xrightarrow{h} & (A'', C'') & = & (A, C) \xrightarrow{h \cdot f} (A'', C'') \\
& \downarrow g & & \downarrow k & & \downarrow k \cdot g
\end{array}$$

is defined by

$$\gamma \bar{*} \alpha = m_{A''} \cdot (\gamma \square_{C''} A'') \cdot {}^{C''} \tilde{\rho}_{A''} \cdot h_1 \cdot (\alpha \square_{C'} {}^h C''') \cdot {}^{C'} \tilde{\rho}_{C''} : C''' \longrightarrow A'' .$$

The unit of (A, C) , for this composition, is the unit of (A, C) , $u_A : C \longrightarrow A$.

Remark 1.5.4.3. Consider the case when the monoidal category $(\mathfrak{M}, \otimes, I)$ in $\mathbf{IntCoCat}(\mathfrak{M})$ is $(\mathbf{Mod}_R^{op}, \otimes_R, R)$, see Section 1.4.1. A cofunctor, in this set up, $(f_1, f_0) : (C, A) \longrightarrow (D, B)$ from the A -coring C to the B -coring D is equivalent to a commutative diagram of functors like

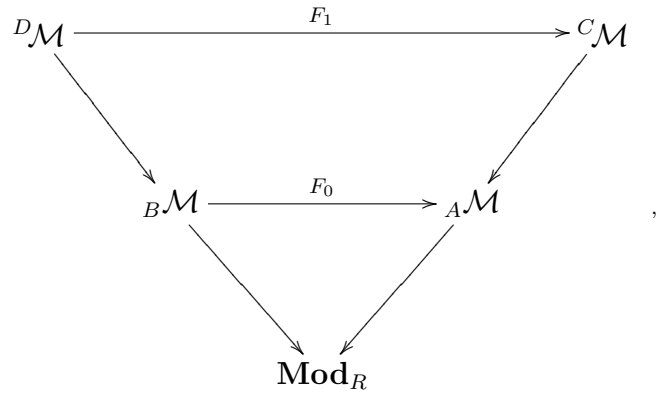

where the functor F_0 is the restriction of scalars corresponding to the R -algebra morphism $f_0 : A \longrightarrow B$ and the unmarked arrows are forgetful functors. Therefore, a cofunctor can be identified with a left extension of corings, [8].

Chapter 2

Classical and Formal Theories of Monads

In this chapter the concept of a monad will be of main importance, therefore we recall it from [26]. Let \mathcal{C} be a category. A *monad* on \mathcal{C} is a triple (F, μ, η^F) , where $F : \mathcal{C} \rightarrow \mathcal{C}$ is a functor and $\mu : FF \rightarrow F$, $\eta^F : 1_{\mathcal{C}} \rightarrow F$ are natural transformations such that the following diagrams commute:

$$\begin{array}{ccc}
 FFF & \xrightarrow{\mu^F} & FF \\
 \downarrow F\mu & & \downarrow \mu \\
 FF & \xrightarrow{\mu} & F
 \end{array}
 , \quad
 \begin{array}{ccc}
 F & \xrightarrow{\eta^{FF}} & FF \\
 \downarrow F\eta^F & \searrow = & \downarrow \mu \\
 FF & \xrightarrow{\mu} & F
 \end{array}
 . \tag{2.1}$$

The first diagram is referred to as the associativity of the monad, and the second one as the unitality of the monad. Dually, a *comonad* on \mathcal{C} is a triple $(G, \delta, \varepsilon^G)$, where $G : \mathcal{C} \rightarrow \mathcal{C}$ is a functor and $\delta : G \rightarrow GG$, $\varepsilon^G : G \rightarrow 1_{\mathcal{C}}$ are natural transformations satisfying conditions dual to those in (2.1).

In this chapter, we describe the classical and formal theories of monads and comonads, following [18], [20], [21], [24] and [30].

Note 2.1. If $\alpha : H \rightarrow K : \mathcal{C} \rightarrow \mathcal{D}$ is a natural transformation in **Cat**, then the notation $\alpha_{\mathcal{C}}$ or $\alpha_{\mathcal{C}}$, over an object in \mathcal{C} , will be used indistinctively.

2.1 Monads and the Associated Category of Adjunctions

This section deals with the category of **F-Adj** of adjunctions associated to a monad (F, μ, η^F) or *F-adjunctions*.

Let

$$\mathcal{C} \begin{array}{c} \xleftarrow{R} \\ \xrightarrow{L} \end{array} \mathcal{D} \quad , \tag{2.2}$$

be an adjunction with domain \mathcal{C} and codomain \mathcal{D} , with unit $\eta : 1_{\mathcal{C}} \longrightarrow RL$ and counit $\varepsilon : LR \longrightarrow 1_{\mathcal{D}}$. When the codomain \mathcal{D} of such an adjunction is irrelevant or understood, the statement *an adjunction over \mathcal{C}* or *an adjunction with domain \mathcal{C}* , will be used instead. Also, the triangular identity $\varepsilon L \circ L\eta = 1_L$ will be referred to as the triangular identity associated to left adjoint L and the identity $R\varepsilon \circ \eta R = 1_R$ as the triangular identity associated to the right adjoint R . Yet another convention for an adjunction like in (2.2) can be stated, whenever suitable the notation for the unit η^{RL} and the counit ε^{LR} will be used, in order to differentiate among units and counits from different adjunctions.

An adjunction like (2.2) induces a monad

$$(RL, R\varepsilon L, \eta) \tag{2.3}$$

on \mathcal{C} . If (F, μ, η^F) is a fixed monad in \mathcal{C} , then one can consider the collection $F\text{-Adj}(\mathcal{C})$ of adjunctions $L \dashv R$ with domain \mathcal{C} such that $(RL, R\varepsilon L, \eta) = (F, \mu, \eta^F)$. Any such adjunction will be denoted by $(\mathcal{D}, L \dashv R, \varepsilon)$ or simply $(\mathcal{D}, L \dashv R)$. $F\text{-Adj}(\mathcal{C})$ is a category with objects $(\mathcal{D}, L \dashv R)$ and morphisms $\bar{J} : (\mathcal{D}, L \dashv R) \longrightarrow (\mathcal{D}', L' \dashv R')$ given by functors $J : \mathcal{D} \longrightarrow \mathcal{D}'$ making the following diagram

$$\begin{array}{ccc}
 & & \mathcal{D} \\
 & \nearrow R & \\
 \mathcal{C} & & \\
 & \searrow L & \\
 & & \mathcal{D}' \\
 & \nearrow R' & \\
 & \searrow L' &
 \end{array}
 ,$$

serially commutative (*i.e.* both the L and R -diagrams commute). As explained in [25], the above requirement together with $\eta = \eta^F = \eta'$ imply that

$$J\varepsilon = \varepsilon'J \ , \tag{2.4}$$

which is one of the requirements imposed on J in [21].

Within the category $F\text{-Adj}(\mathcal{C})$, there are two very important objects which we describe completely. The first one is the so-called *Kleisli category* for the monad (F, μ, η^F) , denoted by \mathcal{C}_F . The objects of the Kleisli category \mathcal{C}_F are the same as those of the original category, *i.e.*

$$Obj(\mathcal{C}) = Obj(\mathcal{C}_F) \ . \tag{2.5}$$

A morphism $f^\natural : A \longrightarrow A'$ in \mathcal{C}_F is given by a morphism in \mathcal{C}

$$f : A \longrightarrow FA' \ . \tag{2.6}$$

The composition for a pair $f^\natural : A \longrightarrow A'$ and $g^\natural : A' \longrightarrow A''$ of morphisms in \mathcal{C}_F , is defined as

$$g^\natural \cdot f^\natural = (\mu_{A''} \cdot Fg \cdot f)^\natural , \quad (2.7)$$

i.e.

$$A \xrightarrow{f} FA' \xrightarrow{Fg} FFA'' \xrightarrow{\mu_{A''}} FA'' \quad .$$

The identity morphism for A in \mathcal{C}_F is

$$(\eta_A^F)^\natural : A \longrightarrow A , \quad (2.8)$$

i.e. the morphism given by the unit $\eta_A^F : A \longrightarrow FA$. That $(\eta_A^F)^\natural$ is a unit for the composition in \mathcal{C}_F follows by the unitality of the monad and the naturality of η^F .

The second category is the so-called category of *Eilenberg-Moore category of algebras* for the monad (F, μ, η^F) , denoted by \mathcal{C}^F . The objects of this category are pairs $(M, {}^F\chi_M)$, where M is an object in \mathcal{C} and ${}^F\chi_M : FM \longrightarrow M$ is a morphism in \mathcal{C} , called the *action of the algebra* or *structure map of the algebra*, such that the following diagrams

$$\begin{array}{ccc} FFM & \xrightarrow{\mu^M} & FM \\ \downarrow F^F\chi_M & & \downarrow F\chi_M \\ FM & \xrightarrow{{}^F\chi_M} & M \end{array} , \quad \begin{array}{ccc} M & \xrightarrow{\eta^FM} & FM \\ & \searrow = & \downarrow F\chi_M \\ & & M \end{array} . \quad (2.9)$$

commute.

A morphism $\bar{f} : (M, {}^F\chi_M) \longrightarrow (M', {}^F\chi_{M'})$ in this category is given by a morphism $f : M \longrightarrow M'$ in \mathcal{C} , such that the following diagram

$$\begin{array}{ccc} FM & \xrightarrow{Ff} & FM' \\ \downarrow F\chi_M & & \downarrow F\chi_{M'} \\ M & \xrightarrow{f} & M' \end{array} \quad (2.10)$$

commutes. Both of these categories belong to $\mathbf{F}\text{-Adj}(\mathcal{C})$, a fact that can be stated as a pair of propositions:

Proposition 2.1.1. *The Kleisli category \mathcal{C}_F is an object in $\mathbf{F}\text{-Adj}(\mathcal{C})$.*

Proof (Sketch):

The adjunction over \mathcal{C}

$$\mathcal{C} \begin{array}{c} \xleftarrow{U_F} \\ \xrightarrow{D_F} \end{array} \mathcal{C}_F \quad , \quad (2.11)$$

is defined as follows. The functor D_F is defined on objects as the identity, and for a morphism $h : C \longrightarrow C'$ in \mathcal{C} , as

$$D_F(h) = (\eta^F C' \cdot h)^\natural \quad . \quad (2.12)$$

The functor U_F is defined on objects A in \mathcal{C}_F , as $U_F(A) = FA$, and on morphisms $f^\natural : A \longrightarrow A'$ as

$$U_F(f^\natural) = \mu A' \cdot Ff : FA \longrightarrow FA' \quad . \quad (2.13)$$

It is straightforward to check that the unit of the adjunction η^K can be defined as $\eta^K = \eta^F$.

The counit, $\varepsilon^K : D_F U_F \longrightarrow 1_{\mathcal{C}_F}$, is defined on objects

$$\varepsilon^{K^\natural} A : FA = D_F U_F(A) \longrightarrow A \quad ,$$

as $\varepsilon^{K^\natural} A = (1_{FA})^\natural$. It is easy to check that $(D_F \dashv U_F, \varepsilon^K)$ is an F -adjunction over \mathcal{C} . □

Proposition 2.1.2. *The Eilenberg-Moore Category \mathcal{C}^F is an object in $\mathbf{F}\text{-Adj}(\mathcal{C})$.*

Proof (Sketch):

The adjunction over \mathcal{C}

$$\mathcal{C} \begin{array}{c} \xleftarrow{U^F} \\ \xrightarrow{D^F} \end{array} \mathcal{C}^F \quad ,$$

is defined as follows. The functor D^F , known as the *free algebra functor*, is defined on an object C , as the pair $(FC, \mu C)$, and is defined on a morphism $h : C \longrightarrow C'$, as

$$D^F(h) = \overline{Fh} .$$

The naturality of μ implies that \overline{Fh} is a morphism in \mathcal{C}^F . The functor U^F , known as the *forgetful functor*, is defined on an object $(M, {}^F\chi_M)$ in \mathcal{C}^F as M , and for a morphism $\overline{f} : (M, {}^F\chi_M) \longrightarrow (M', {}^F\chi_{M'})$ as

$$U^F(\overline{f}) = f .$$

It is straightforward to check that the unit η^E for this adjunction can be defined as $\eta^E = \eta^F$.

The counit $\varepsilon^E : D^F U^F \longrightarrow 1_{\mathcal{C}^F}$ is defined on objects

$$\overline{\varepsilon^E}(M, {}^F\chi_M) : (FM, \mu M) = D^F U^F(M, {}^F\chi_M) \longrightarrow (M, {}^F\chi_M) , \quad (2.14)$$

as $\overline{\varepsilon^E}(M, {}^F\chi_M) = \overline{{}^F\chi_M}$. This is well-defined since the first requirement for the action ${}^F\chi_M$, (2.9) can be identified as a requirement for ${}^F\chi_M$ to be a morphism in \mathcal{C}^F . The proof that $(D^F \dashv U^F, \varepsilon^E)$ is an object in $\mathbf{F}\text{-Adj}(\mathcal{C})$ is left to the reader. \square

The main property of these two categories is that they are universal objects in the category $\mathbf{F}\text{-Adj}(\mathcal{C})$.

Proposition 2.1.3. *The Kleisli category \mathcal{C}_F for a monad (F, μ, η^F) is an initial object in $\mathbf{F}\text{-Adj}(\mathcal{C})$.*

Proof:

Let $(\mathcal{D}, L \dashv R)$ be an object in $\mathbf{F}\text{-Adj}(\mathcal{C})$. Then the *a posteriori* unique functor K_F ,

$$\begin{array}{ccc} & & \mathcal{C}_F \\ & \nearrow U_F & \downarrow K_F \\ \mathcal{C} & \xrightarrow{D_F} & \mathcal{D} \\ & \xleftarrow{R} & \downarrow \\ & \xrightarrow{L} & \mathcal{D} \end{array} ,$$

is defined on objects A in \mathcal{C}_F , as

$$K_F(A) = LA , \quad (2.15)$$

and on morphisms $f^\natural : A \longrightarrow A'$, as

$$K_F(f^\natural) = \varepsilon LA' \cdot Lf : LA \longrightarrow LA' .$$

The commutativity of the left adjoint functors is checked in the following way. Let C be an object in \mathcal{C} . Then $K_F D_F(C) = K_F(C) = L(C)$. Let $h : C \longrightarrow C'$ be a morphism in \mathcal{C} . Then

$$K_F D_F(h) = K_F(\eta^F C' \cdot h)^\natural = \varepsilon L C' \cdot L(\eta^F C' \cdot h) = \varepsilon L C' \cdot L \eta^F C' \cdot L h = L h ,$$

where the last equality comes from the triangular identity associated to the left adjoint L . Thus, $K_F D_F = L$, as required.

On the other hand, the commutativity of the right adjoints is proved in the following way. Let A be an object in \mathcal{C}_F . Then $RK_F(A) = RL(A) = F(A) = U_F(A)$. Let $f^\natural : A \longrightarrow A'$ be a morphism in \mathcal{C}_F . Then

$$RK_F(f^\natural) = R(\varepsilon L A' \cdot L f) = R \varepsilon L A' \cdot R L f = \mu A' \cdot F f = U_F(f^\natural) .$$

Therefore, $RK_F = U_F$, as required.

To prove that K_F is unique, suppose that there is another morphism in $\mathbf{F-Adj}(\mathcal{C})$, say $J : \mathcal{C}_F \longrightarrow \mathcal{D}$. Let A be in \mathcal{C}_F . Since the functor D_F is the identity on objects, then $JA = JD_F A$. Furthermore, J is a morphism in $\mathbf{F-Adj}(\mathcal{C})$ hence $JD_F = L$, therefore $JA = LA$. On the other hand, let $f^\natural : A \longrightarrow A'$ be a morphism in \mathcal{C}_F . The requirement $JD_F = L$ gives

$$JD_F(f) = J((\eta^F F A' \cdot f)^\natural) = L f .$$

Next, the property (2.4) evaluated at A' , reads $J(1_{FA'})^\natural = \varepsilon L A'$. Therefore

$$\begin{aligned} J(f^\natural) &= J((\mu A' \cdot \eta^F F A' \cdot f)^\natural) &= J((\mu A' \cdot F(1_{FA'}) \cdot \eta^F F A' \cdot f)^\natural) \\ & &= J((1_{FA'})^\natural \cdot (\eta^F F A' \cdot f)^\natural) \\ & &= J((1_{FA'})^\natural) J((\eta^F F A' \cdot f)^\natural) \\ & &= \varepsilon L A' \cdot L f , \end{aligned}$$

where in the second equality, the definition of the composition in \mathcal{C}_F , (2.7), was used. The previous calculation determines the definition of J on morphisms, so $J = K_F$ \square

Proposition 2.1.4. *The Eilenberg-Moore category \mathcal{C}^F for a monad (F, μ, η^F) is a final object in $\mathbf{F-Adj}(\mathcal{C})$.*

Proof:

Let $(\mathcal{D}, L \dashv R)$ be an object in $\mathbf{F}\text{-Adj}(\mathcal{C})$. The *a posteriori* unique functor K^F , called *comparison functor*,

$$\begin{array}{ccc} \mathcal{C} & \begin{array}{c} \xleftarrow{R} \\ \xrightarrow{L} \end{array} & \mathcal{D} \\ & \begin{array}{c} \searrow U^F \\ \swarrow D^F \end{array} & \downarrow K^F \\ & & \mathcal{C}^F \end{array} ,$$

is defined on objects D in \mathcal{D} , as

$$K^F(D) = (RD, R\varepsilon D) . \quad (2.16)$$

On morphisms $r : D \longrightarrow D'$, K^F is defined as

$$K^F(r) = \overline{Rr} : (RD, R\varepsilon D) \longrightarrow (RD', R\varepsilon D') . \quad (2.17)$$

The commutativity of the left adjoint functors is checked in the following way. Let C be an object in \mathcal{C} . Then $K^F L(C) = (RLC, R\varepsilon LC) = (FC, \mu C) = D_F(C)$. Let $h : C \longrightarrow C'$ be a morphism in \mathcal{C} , then

$$K^F L(h) = \overline{RLf} = \overline{Ff} = D^F(f) ,$$

where the definition of the induced monad by an adjunction, (2.3), is used. Thus, $K^F L = D^F$, as required.

On the other hand, the commutativity of the right adjoints is proved in the following way. Let D be an object in \mathcal{D} . Then $U^F K^F(D) = U^F(RD, R\varepsilon D) = R(D)$. Let $r : D \longrightarrow D'$ in \mathcal{D} be a morphism in \mathcal{D} . Then

$$U^F K^F(r) = U^F(\overline{Rr}) = Rr .$$

Therefore, $U^F K^F = R$, as required.

To prove that K^F is unique, suppose that there exists another morphism $J : \mathcal{D} \rightarrow \mathcal{C}^F$ in $\mathbf{F}\text{-Adj}(\mathcal{A})$. Let D be an object in \mathcal{D} . Then $J(D) = (M, {}^F\chi_M)$, since $U^F J = R$ the object M is determined as $M = RD$. Before determining the action, let $r : D \longrightarrow D'$ be a morphism in \mathcal{D} . Due to the fact that J is a morphism in $\mathbf{F}\text{-Adj}(\mathcal{C})$, $U^F J = R$, hence $U^F J r = Rr$. Using this behaviour of $U^F J$ on morphisms,

$$R\varepsilon D = U^F J\varepsilon D = U^F \overline{\varepsilon^E} J D = U^F \overline{\varepsilon^E} (RD, {}^F\chi_M) = U^F(\overline{{}^F\chi_M}) = {}^F\chi_M .$$

Thus, the action ${}^F\chi_M$ is determined by the value $R\varepsilon D$. Furthermore, due to this determination, we can now conclude that $Jr = \overline{Rr} = K^F r$. This determines the definition of J on morphisms, so $J = K^F$. \square

2.2 Comonads and the Associated Category of Adjunctions

Dual to the previous section, consider a comonad $(G, \delta, \varepsilon^G)$ on the category \mathcal{D} . Let us define a category that has, by objects, adjunctions with codomain \mathcal{D}

$$\mathcal{C} \begin{array}{c} \xleftarrow{R} \\ \xrightarrow{L} \end{array} \mathcal{D} \quad ,$$

such that the comonad induced on \mathcal{D} is precisely the one given at first, *i.e.* $(LR, L\eta R, \varepsilon) = (G, \delta, \varepsilon^G)$. The notation for such an adjunction is $(\mathcal{C}, L \dashv R, \eta)$, or $(\mathcal{C}, L \dashv D)$ for short, leaving the unit understood. The morphisms of this category $\overline{J} : (\mathcal{C}, L \dashv D) \longrightarrow (\mathcal{C}', L' \dashv D')$ are functors $J : \mathcal{C} \longrightarrow \mathcal{C}'$ such that the diagram

$$\begin{array}{ccc} \mathcal{C} & & \\ \downarrow J & \begin{array}{c} \xleftarrow{R} \\ \xrightarrow{L} \end{array} & \mathcal{D} \\ \mathcal{C}' & \begin{array}{c} \xleftarrow{R'} \\ \xrightarrow{L'} \end{array} & \end{array} \quad ,$$

commutes serially. Within this category there are also two universal objects, which, contrary to the previous subsection, are going to be only slightly explained. The *Kleisli category* for the comonad $(G, \delta, \varepsilon^G)$ over \mathcal{D} and denoted by \mathcal{D}^G . The objects of this category are the same as the original one

$$Obj(\mathcal{D}) = Obj(\mathcal{D}^G) \quad .$$

The morphisms in \mathcal{D}^G are $h^\natural : A \longrightarrow A'$ if and only if

$$h : GA \longrightarrow A' \quad ,$$

is a morphism in \mathcal{D} , and the composition for the pair $h^\natural : A \longrightarrow A'$ and $k^\natural : A' \longrightarrow A''$ is defined as

$$k^\natural \cdot h^\natural = (k \cdot Gh \cdot \delta_A)^\natural : A \longrightarrow A'' \quad .$$

The unit of A for this composition is

$$(\varepsilon_A^G)^\natural : A \longrightarrow A ,$$

since $\varepsilon_A^G : GA \longrightarrow A$.

The second category is the category known as the *Eilenberg-Moore category of coalgebras or comodules* for the comonad $(G, \delta, \varepsilon^G)$ and denoted by \mathcal{D}_G . The objects of this category are G -comodules or comodules for short, $(M, {}^G\rho_M)$ in \mathcal{D} such that the following diagrams

$$\begin{array}{ccc} GGM & \xleftarrow{\delta_M} & GM \\ \uparrow G^G\rho_M & & \uparrow G^G\rho_M \\ GM & \xleftarrow{{}^G\rho_M} & M \end{array} , \quad \begin{array}{ccc} M & \xleftarrow{\varepsilon_M^G} & GM \\ & \searrow = & \uparrow G^G\rho_M \\ & & M \end{array} .$$

commute.

A morphism in this category $\bar{r} : (M, {}^G\rho_M) \longrightarrow (M', {}^G\rho_{M'})$ is such that $r : M \longrightarrow M'$ is a morphism in \mathcal{D} and the following diagram

$$\begin{array}{ccc} GM & \xrightarrow{Gr} & GM' \\ \uparrow G^G\rho_M & & \uparrow G^G\rho_{M'} \\ M & \xrightarrow{r} & M' \end{array} ,$$

commutes.

These two categories belong also to the category $\mathbf{G}\text{-Adj}(\mathcal{D})$, and not only that but the following two propositions can be stated

Proposition 2.2.1. *The Kleisli category \mathcal{D}^G , for the comonad $(G, \delta, \varepsilon^G)$ over \mathcal{D} , is an initial object in the category $\mathbf{G}\text{-Adj}(\mathcal{D})$.*

Proof: cf. 2.1.3. □

Proposition 2.2.2. *The Eilenberg-Moore category \mathcal{D}_G , for the comonad $(G, \delta, \varepsilon^G)$ over \mathcal{D} , is a final object in the category $\mathbf{G}\text{-Adj}(\mathcal{D})$.*

Proof: cf. 2.1.4. □

2.3 Formal Theory of Monads

In this section, the notation $\alpha : f \longrightarrow g : A \longrightarrow B$ for a 2-cell in the 2-category \mathcal{A} , is widely used.

The formal theory of monads was developed in [20] and [30]. The following presentation makes also use of [18] and [24].

For the formal theory of monads, let \mathcal{A} be a 2-category, and define the *2-category of monads*, $\mathbf{Mnd}(\mathcal{A})$, as follows:

i) 0-cells of $\mathbf{Mnd}(\mathcal{A})$ are (A, f, μ, η^f) , where (f, μ, η^f) is a monad on A . A monad in the 2-category \mathcal{A} is understood as a 1-cell $f : A \longrightarrow A$, and 2-cells $\mu : ff \longrightarrow f : A \longrightarrow A$ and $\eta^f : 1_A \longrightarrow f : A \longrightarrow A$, depicted as

$$\begin{array}{c} \begin{array}{ccc} & ff & \\ \curvearrowright & & \curvearrowright \\ A & \downarrow \mu & A \\ \curvearrowleft & & \curvearrowleft \\ & f & \end{array} , \quad \begin{array}{ccc} & 1_A & \\ \curvearrowright & & \curvearrowright \\ A & \downarrow \eta^f & A \\ \curvearrowleft & & \curvearrowleft \\ & f & \end{array} , \end{array}$$

such that the following diagrams

$$\begin{array}{ccc} \begin{array}{ccc} fff & \xrightarrow{\mu^f} & ff \\ \downarrow f\mu & & \downarrow \mu \\ ff & \xrightarrow{\mu} & f \end{array} , & \begin{array}{ccc} f & \xrightarrow{\eta^f f} & ff \\ \downarrow f\eta^f & \searrow = & \downarrow \mu \\ ff & \xrightarrow{\mu} & f \end{array} , \end{array}$$

commute. Sometimes, the shorthand notation (A, f) , for such a 0-cell, is used instead.

ii) 1-cells of $\mathbf{Mnd}(\mathcal{A})$ are

$$(p, \varphi) : (A, f, \mu^f, \eta^f) \longrightarrow (A', h, \mu^h, \eta^h) , \quad (2.18)$$

where $p : A \longrightarrow A'$ is a 1-cell in \mathcal{A} , and φ is a 2-cell in \mathcal{A} ,

$$\begin{array}{ccc} A & \xrightarrow{p} & A' \\ \downarrow f & & \downarrow h \\ A & \xrightarrow{p} & A' \end{array} , \quad \varphi \quad (2.19)$$

such that the following diagrams commute:

$$\begin{array}{ccc}
 hhp & \xrightarrow{h\varphi} & hpf & \xrightarrow{\varphi f} & pff \\
 \downarrow \mu^h p & & & & \downarrow p\mu^f \\
 hp & \xrightarrow{\varphi} & pf & &
 \end{array} , \quad
 \begin{array}{ccc}
 & p & \\
 \eta^h p \swarrow & & \searrow p\eta^f \\
 hp & \xrightarrow{\varphi} & pf
 \end{array} . \tag{2.20}$$

iii) 2-cells of $\mathbf{Mnd}(\mathcal{A})$ are,

$$\bar{\Phi} : (p, \varphi) \longrightarrow (q, \psi) : (A, f) \longrightarrow (A', h) ,$$

where Φ is a 2-cell in \mathcal{A} ,

$$\begin{array}{ccc}
 & p & \\
 A & \downarrow \Phi & A' \\
 & q &
 \end{array} ,$$

such that

$$\begin{array}{ccc}
 hp & \xrightarrow{h\Phi} & hq \\
 \downarrow \varphi & & \downarrow \psi \\
 pf & \xrightarrow{\Phi f} & qf
 \end{array} , \tag{2.21}$$

commutes.

The composition of the underlying category $(\mathbf{Mnd}_0, \mathbf{Mnd}_1, \cdot)$, see Section 1.5.1, is defined as follows:

$$(A, f) \xrightarrow{(p, \varphi)} (A', f') \xrightarrow{(q, \psi)} (A'', f'') = (A, f) \xrightarrow{(q \cdot p, q\varphi \circ \psi p)} (A'', f'') .$$

In order to check that $(q \cdot p, q\varphi \circ \psi p)$ is well-defined, the pasting operation of 2-cells have to be explained. This operation is explained over one of the most simple possible cases,

$$\begin{array}{ccc}
 A & \xrightarrow{f} & B \\
 \searrow g & & \downarrow \alpha \\
 & & C \\
 & \nearrow s & \downarrow \beta \\
 & & D \\
 C & \xrightarrow{k} & D
 \end{array}
 \quad . \quad (2.22)$$

The pasting operation for this 2-cell composition is

$$\begin{array}{ccc}
 & \xrightarrow{h \cdot f} & \\
 & \downarrow 1_h * \alpha & \\
 A & \xrightarrow{hsg} & B \\
 & \downarrow \beta * 1_g & \\
 & \xrightarrow{k \cdot g} &
 \end{array}
 \quad .$$

In this way, more complex pasting operations can be carried out. For a more detailed explanation the reader is referred to [18]. Resuming to the well-definition of $(q \cdot p, q\varphi \circ \psi p)$, consider

$$\begin{array}{ccc}
 A \xrightarrow{p} A' \xrightarrow{q} A'' & & A \xrightarrow{q \cdot p} A'' \\
 \searrow f & \searrow f' & \searrow f'' \\
 & \downarrow \varphi & \downarrow \psi \\
 & A' & A'' \\
 & \downarrow p & \downarrow q \\
 & A & A'
 \end{array}
 \quad = \quad
 \begin{array}{ccc}
 A \xrightarrow{q \cdot p} A'' & & \\
 \searrow f & \searrow f'' & \\
 & \downarrow q \varphi \circ \psi p & \\
 & A' & \\
 & \downarrow q \cdot p & \\
 & A &
 \end{array}
 \quad .$$

Because of this, the 1-cell $(q \cdot p, q\varphi \circ \psi p)$ is well-defined. The requirement (2.21) for the composition of 1-cells is not going to be done in order to avoid doubling the length of this chapter. The unit of the 0-cell (A, f) for the composition of this underlying category, is $(1_A, 1_f) : (A, f) \longrightarrow (A, f)$.

For the pair of 0-cells (A, f) and (A', h) , the vertical structure in $\mathbf{Mnd}(\mathcal{A})$, *i.e.* the composition for the category $(\mathbf{Mnd}_1((A, f), (A', h)), \mathbf{Mnd}_2((A, f), (A', h)), \circ)$, is defined as follows. Consider the following 2-diagram

$$\begin{array}{ccc}
 & \xrightarrow{(p, \varphi)} & \\
 & \downarrow \bar{\Phi} & \\
 (A, f) & \xrightarrow{(r, \rho)} & (A', h) \\
 & \downarrow \bar{\Psi} & \\
 & \xrightarrow{(q, \psi)} &
 \end{array}
 \quad = \quad
 \begin{array}{ccc}
 & \xrightarrow{(p, \varphi)} & \\
 & \downarrow \bar{\Psi} \circ \bar{\Phi} & \\
 (A, f) & & (A', h) \\
 & \xrightarrow{(q, \psi)} &
 \end{array}
 \quad ,$$

where $\bar{\Psi} \circ \bar{\Phi} = \overline{\Psi \circ \Phi}$, which is well defined because of the following equality between commutative diagrams

$$\begin{array}{ccc}
hp & \xrightarrow{h\Phi} & hr & \xrightarrow{h\Psi} & hq & & hp & \xrightarrow{h(\Psi\circ\Phi)} & hq \\
\downarrow \varphi & & \downarrow \rho & & \downarrow \psi & = & \downarrow \varphi & & \downarrow \psi \\
pf & \xrightarrow{\Phi_f} & rf & \xrightarrow{\Psi_f} & qf & & pf & \xrightarrow{(\Psi\circ\Phi)_f} & qf
\end{array}$$

This composition just defined inherits the associativity from the 2-category \mathcal{A} . The unit of the 1-cell (p, φ) for this vertical product is defined as $\overline{1_{(p, \varphi)}} = \overline{1_p}$.

The horizontal structure in $\mathbf{Mnd}(\mathcal{A})$, for the category $(\mathbf{Mnd}_0, \mathbf{Mnd}_1, \bar{*})$ is defined as follows. Consider the following 2-diagram,

$$\begin{array}{ccc}
& (p, \varphi) & (p', \varphi') & & (p' \cdot p, p' \varphi \circ \varphi' p) \\
& \curvearrowright & \curvearrowright & & \curvearrowright \\
(A, f) & \downarrow \overline{\Phi} & (A', h) & \downarrow \overline{\Gamma} & (A'', k) = (A, f) \downarrow \overline{\Gamma \bar{*} \Phi} (A'', k) , \\
& \curvearrowleft & \curvearrowleft & & \curvearrowleft \\
& (q, \psi) & (q', \psi') & & (q' \cdot q, q' \psi \circ \psi' q)
\end{array}$$

where $\overline{\Gamma \bar{*} \Phi} = \overline{\Gamma \bar{*} \Phi}$. Due to the lengthy calculation of the respective commutative diagram, the proof of the well-definition of this composition is not done here. The unit 2-cell of (A, f) for this composition is $\overline{1_{(A, f)}} = \overline{1_A}$. All this provides $\mathbf{Mnd}(\mathcal{A})$ with a structure of a 2-category.

Consider the *inclusion 2-functor*,

$$Inc_{\mathcal{A}} : \mathcal{A} \longrightarrow \mathbf{Mnd}(\mathcal{A}) ,$$

defined as follows. For a 0-cell B , $Inc_{\mathcal{A}}(B) = (B, 1_B, 1_{1_B}, 1_{1_B})$. For a 1-cell $b : B \longrightarrow B'$, is defined as $Inc_{\mathcal{A}}(b) = (b, 1_b)$,

$$\begin{array}{ccc}
& (b, 1_b) & \\
& \curvearrowright & \\
(B, 1_B) & & (B', 1_{B'}) .
\end{array}$$

For a 2-cell, $\beta : b \longrightarrow b' : B \longrightarrow B'$, $Inc_{\mathcal{A}}(\beta) = \overline{\beta}$, where

$$\begin{array}{ccc}
& (b, 1_b) & \\
& \curvearrowright & \\
(B, 1_B) & \downarrow \overline{\beta} & (B', 1_{B'}) . \\
& \curvearrowleft & \\
& (b', 1_{b'}) &
\end{array}$$

Definition 2.3.1. *The 2-category \mathcal{A} is said to admit the construction of algebras if the inclusion functor $Inc_{\mathcal{A}} : \mathcal{A} \longrightarrow \mathbf{Mnd}(\mathcal{A})$ has a right adjoint, in which case it is denoted by*

$$Alg_{\mathcal{A}} : \mathbf{Mnd}(\mathcal{A}) \longrightarrow \mathcal{A} \quad .$$

For the sake of referencing, this 2-adjunction is fully displayed as

$$\mathcal{A} \begin{array}{c} \xleftarrow{Alg_{\mathcal{A}}} \\ \xrightarrow{Inc_{\mathcal{A}}} \end{array} \mathbf{Mnd}(\mathcal{A}) \quad . \quad (2.23)$$

Suppose that the 2-category \mathcal{A} admits the construction of algebras. Then according to [19] and [28], for every pair of 0-cells, B and (A, f) , in \mathcal{A} and $\mathbf{Mnd}(\mathcal{A})$, respectively, there is an isomorphism between the following categories,

$$Hom_{\mathcal{A}}(B, Alg_{\mathcal{A}}(A, f)) \cong Hom_{\mathbf{Mnd}(\mathcal{A})}(Inc_{\mathcal{A}}(B), (A, f)) \quad ,$$

which follows by the Yoneda lemma for 2-categories. If the following notations are taken into account, $F = (f, \mu, \eta^f)$, $A^E = Alg_{\mathcal{A}}(A, f)$, $Alg^F_{-} = Hom_{\mathbf{Mnd}(\mathcal{A})}(Inc_{\mathcal{A}}(_), (A, f))$, then the previous isomorphism can be read, over the 0-cell B , as

$$Hom_{\mathcal{A}}(B, A^E) \cong Alg^F(B) \quad .$$

The 0-cell A^E is termed as an *Eilenberg-Moore object* in \mathcal{A} , because it represents the 2-functor $Alg^F(_)$, cf. [24]. Therefore, Definition 2.3.1 can be rephrased as follows: the 2-category \mathcal{A} admits the construction of algebras if and only if it has Eilenberg-Moore objects for any monad $F = (f, \mu, \eta^f)$ over A , in \mathcal{A} .

In order to find the *Kleisli objects* in \mathcal{A} , let us make the following observation. According to [15, I.6], the following are equivalent

- i) $l \dashv r$
- ii) $r^{op} \dashv l^{op}$
- iii) $r^{co} \dashv l^{co}$
- iv) $l^{coop} \dashv r^{coop}$.

If Definition 2.3.1 is considered, then the 2-category \mathcal{A}^{op} is said to have the construction of algebras, if the following adjunction takes place

$$\mathcal{A}^{op} \begin{array}{c} \xleftarrow{Alg_{\mathcal{A}^{op}}} \\ \xrightarrow{Inc_{\mathcal{A}^{op}}} \end{array} \mathbf{Mnd}(\mathcal{A}^{op}) \quad ,$$

which can be read, due to the very previous observation applied to the 2-category 2-Cat , as

$$\mathbf{Mnd}^{op}(\mathcal{A}^{op}) \begin{array}{c} \xleftarrow{Inc_{\mathcal{A}^{op}}^{op}} \\ \xrightarrow{Alg_{\mathcal{A}^{op}}^{op}} \end{array} \mathcal{A} \quad , \quad (2.24)$$

Therefore, the following isomorphism of categories exists. For all, B in \mathcal{A} and (A, f) in $\mathbf{Mnd}^{op}(\mathcal{A}^{op})$

$$Hom_{\mathbf{Mnd}^{op}(\mathcal{A}^{op})}((A, f), Inc_{\mathcal{A}^{op}}^{op}(B)) \cong Hom_{\mathcal{A}}(Alg_{\mathcal{A}^{op}}^{op}(A, f), B) \quad .$$

In the same way as before, in terms of the notation, $F = (f, \mu, \eta^f)$, $A_K = Alg_{\mathcal{A}^{op}}^{op}(A, f)$ and $Alg_{F-} = Hom_{\mathbf{Mnd}^{op}(\mathcal{A}^{op})}((A, f), Inc_{\mathcal{A}^{op}}^{op}-)$, the isomorphism of categories, for the 0-cell B , reads

$$Alg_F(B) \cong Hom_{\mathcal{A}}(A_K, B) \quad . \quad (2.25)$$

The 0-cell A_K is called a *Kleisli object* in \mathcal{A} , because it represents the functor $Alg_F(-)$, cf. [24]. And saying that \mathcal{A}^{op} admits the construction of algebras is equivalent for \mathcal{A} having Kleisli objects for any monad $F = (f, \mu, \eta^f)$ over A in \mathcal{A} .

Yet again, if Definition 2.3.1 is considered, then the 2-category \mathcal{A}^{co} is said to have the construction of algebras if the following adjunction takes place

$$\mathcal{A}^{co} \begin{array}{c} \xleftarrow{Alg_{\mathcal{A}^{co}}} \\ \xrightarrow{Inc_{\mathcal{A}^{co}}} \end{array} \mathbf{Mnd}(\mathcal{A}^{co}) \quad ,$$

which also reads as

$$\mathbf{Mnd}^{co}(\mathcal{A}^{co}) \begin{array}{c} \xleftarrow{Inc_{\mathcal{A}^{co}}^{co}} \\ \xrightarrow{Alg_{\mathcal{A}^{co}}^{co}} \end{array} \mathcal{A} \quad .$$

This renders the following isomorphism of categories. For all B in \mathcal{A} and (A, g) a comonad over A ,

$$Hom_{\mathbf{Mnd}^{co}(\mathcal{A}^{co})}((A, g), Inc_{\mathcal{A}^{co}}^{co}(B)) \cong Hom_{\mathcal{A}}(Alg_{\mathcal{A}^{co}}^{co}(A, g), B) \quad .$$

Yet again, if the following definitions are made, $G = (g, \delta, \varepsilon^g)$, $A_{coK} = Alg_{\mathcal{A}^{co}}^{co}(A, g)$ and $Coalg_{G-} = Hom_{\mathbf{Mnd}^{co}(\mathcal{A}^{co})}((A, g), Inc_{\mathcal{A}^{co}}^{co}-)$, then the isomorphism of categories, over the 0-cell B , reads this time as

$$\mathit{Coalg}_G(B) \cong \mathit{Hom}_{\mathcal{A}}(A_{coK}, B) . \quad (2.26)$$

The 0-cell A_{coK} is known as a *coKleisli object* in \mathcal{A} , because it represents the functor $\mathit{Coalg}_G(_)$, cf. [24]. And saying that \mathcal{A}^{co} admits the construction of algebras is equivalent to \mathcal{A} having coKleisli objects for any comonad $G = (g, \delta, \varepsilon^g)$ over A in \mathcal{A} .

In what follows, the 2-category $\mathbf{Mnd}^{op}(\mathcal{A}^{op})$ is of particular importance, in order to get the Kleisli objects in the 2-category $\mathbf{IntCat}(\mathfrak{M})$, hence we describe it explicitly (with some minor changes in the notation used for $\mathbf{Mnd}(\mathcal{A})$).

i) The 0-cells of this 2-category are (A, f, μ^f, η^f) , *i.e.* monads in \mathcal{A} ,

ii) The 1-cells of this 2-category are

$$(r, \rho) : (A, f) \longrightarrow (A', h) ,$$

such that $r : A \longrightarrow A'$ is a 1-cell in \mathcal{A} , and ρ is a 2-cell in \mathcal{A} ,

$$\begin{array}{ccc} A & \xrightarrow{r} & A' \\ f \downarrow & & \downarrow h \\ A & \xrightarrow{r} & A' \end{array} , \quad \rho$$

such that the following diagrams commute:

$$\begin{array}{ccccc} rff & \xrightarrow{\rho f} & hrf & \xrightarrow{h\rho} & hhr \\ r\mu^f \downarrow & & & & \downarrow \mu^{hr} \\ rf & \xrightarrow{\rho} & hr & & \end{array} , \quad \begin{array}{ccc} & r & \\ r\eta^f \swarrow & & \searrow \eta^{hr} \\ rf & \xrightarrow{\rho} & hr \end{array} .$$

iii) The 2-cells of this 2-category are

$$\bar{\Sigma} : (r, \rho) \longrightarrow (s, \sigma) : (A, f) \longrightarrow (A', h) ,$$

where Σ is a 2-cell in \mathcal{A}

$$A \begin{array}{c} \xrightarrow{r} \\ \downarrow \Sigma \\ \xrightarrow{s} \end{array} A' ,$$

such that

$$\begin{array}{ccc} rf & \xrightarrow{\Sigma f} & sf \\ \rho \downarrow & & \downarrow \sigma \\ hr & \xrightarrow{h\Sigma} & hs \end{array} ,$$

commutes. With this description of $\mathbf{Mnd}^{op}(\mathcal{A}^{op})$ at hand the algebraic Kleisli 2-functor can be fully characterized. This Algebraic Kleisli 2-functor for a monad $F = (f, \mu, \eta^f)$ over A is

$$Alg_F(_) = Hom_{\mathbf{Mnd}^{op}(\mathcal{A}^{op})}((A, f), Inc_{\mathcal{A}^{op}}^{op}(_)) : \mathcal{A} \longrightarrow {}_2\mathbf{Cat} ,$$

which acts on 0-cells B in \mathcal{A} as

$$Alg_F(B) = B_F ,$$

where $B_F = \mathbf{Mon}^{op}(\mathcal{A}^{op})((A, f), (B, 1_B))$ is a category. The objects in this category are pairs (r, ρ) , where ρ is the following 2-cell

$$A \begin{array}{c} \xrightarrow{rf} \\ \downarrow \rho \\ \xrightarrow{r} \end{array} B ,$$

such that the following diagrams

$$\begin{array}{ccc} rff & \xrightarrow{r\mu} & rf \\ \rho f \downarrow & & \downarrow \rho \\ rf & \xrightarrow{\rho} & r \end{array} , \quad \begin{array}{ccc} r & \xrightarrow{r\eta^f} & rf \\ & \searrow = & \downarrow \rho \\ & & r \end{array} , \tag{2.27}$$

commute. A morphism in B_F , $\bar{\Sigma} : (r, \rho) \longrightarrow (s, \sigma)$, is a 2-cell

$$\begin{array}{ccc}
 & r & \\
 & \curvearrowright & \\
 A & \downarrow \Sigma & B \\
 & \curvearrowleft & \\
 & s &
 \end{array} , \tag{2.28}$$

such that the following diagram

$$\begin{array}{ccc}
 rf & \xrightarrow{\Sigma f} & sf \\
 \rho \downarrow & & \downarrow \sigma \\
 r & \xrightarrow{\Sigma} & s
 \end{array} , \tag{2.29}$$

commutes.

The algebraic Kleisli 2-functor acts on 1-cells $b : B \longrightarrow B'$ in \mathcal{A} , as

$$Alg_F(b) = b_F : B_F \longrightarrow B'_F ,$$

where b_F is a functor. This, in turn, acts on objects (r, ρ) as

$$b_F(r, \rho) = (br, b\rho) ,$$

and over morphisms, $\bar{\Sigma} : (r, \rho) \longrightarrow (s, \sigma)$, as

$$b_F(\bar{\Sigma}) = \bar{b}\bar{\Sigma} : (br, b\rho) \longrightarrow (bs, b\sigma) .$$

The algebraic Kleisli 2-functor acts on 2-cells

$$\begin{array}{ccc}
 & b & \\
 & \curvearrowright & \\
 B & \downarrow \beta & B' \\
 & \curvearrowleft & \\
 & b' &
 \end{array} ,$$

as $Alg_F(\beta) = \beta_F$, where $\beta_F : b_F \longrightarrow b'_F : B_F \longrightarrow B'_F$ is a natural transformation such that

$$\beta_F(r, \rho) = \overline{\beta r} : (br, b\rho) \longrightarrow (b'r, b'\rho) .$$

This finishes the complete description of the algebraic Kleisli 2-functor $Alg_F(_) : \mathcal{A} \longrightarrow {}_2\mathbf{Cat}$.

2.3.1 The 2-Category $\mathbf{KL}(\mathcal{A})$

The 2-category $\mathbf{KL}(\mathcal{A})$ is the Kleisli completion of the 2-category \mathcal{A} , its construction is fully explained in [20]. The 2-category $\mathbf{KL}(\mathcal{A})$ has by 0-cells those given by the 0-cells of $\mathbf{Mnd}(\mathcal{A})$, that is to say, (A, f, μ, η^f) . The 1-cells of $\mathbf{KL}(\mathcal{A})$, from (A, f, μ^f, η^f) to (A', h, μ^h, η^h) , are given by

$$(A, f) \begin{array}{c} \xrightarrow{(p, \varphi)} \\ \searrow \quad \nearrow \\ (A', h) \end{array} ,$$

such that $p : A \longrightarrow A'$ is a 1-cell in \mathcal{A} , and $\varphi : pf \longrightarrow hp : A \longrightarrow A'$ a 2-cell in \mathcal{A} . Note the inversion in the 2-cell definition for this 2-category with that of $\mathbf{Mnd}(\mathcal{A})$, given by (2.19). This 2-cell is required to fulfill the commutativity of similar diagrams like those given in (2.20). The 2-cells of the 2-category $\mathbf{KL}(\mathcal{A})$ differ substantially from those of $\mathbf{Mnd}(\mathcal{A})$, and are described as follows.

$$\overline{\Lambda} : (p, \varphi) \longrightarrow (q, \psi) : (A, f) \longrightarrow (A', h)$$

is a 2-cell in \mathcal{A} ,

$$A \begin{array}{c} \xrightarrow{p} \\ \downarrow \Lambda \\ \xrightarrow{hq} \end{array} A' ,$$

such that the following diagram

$$\begin{array}{ccccc} pf & \xrightarrow{\varphi} & hp & \xrightarrow{h\Lambda} & hhq \\ \Lambda f \downarrow & & & & \downarrow \mu^h q \\ hqf & & & & \\ h\psi \downarrow & & & & \\ hhq & \xrightarrow{\mu^h q} & & & hq \end{array} ,$$

commutes.

The underlying categorical structure of this 2-category, $(\mathbf{KL}_0(\mathcal{A}), \mathbf{KL}_1(\mathcal{A}), \cdot)$, is defined by the following composition

$$(A, f) \xrightarrow{(p, \varphi)} (A', f') \xrightarrow{(q, \psi)} (A'', f'') = (A, f) \xrightarrow{(q \cdot p, \psi p \circ q \varphi)} (A'', f'') .$$

The unit of (A, f) with respect to this composition is $(1_A, 1_f)$. The vertical structure of this 2-category is defined by the following 2-diagram

$$(A, f) \begin{array}{c} \xrightarrow{(p, \phi)} \\ \downarrow \bar{\Lambda} \\ \xrightarrow{(r, \rho)} \\ \downarrow \bar{\Lambda}' \\ \xrightarrow{(q, \psi)} \end{array} (A', h) = (A, f) \begin{array}{c} \xrightarrow{(p, \phi)} \\ \downarrow \bar{\Lambda}' \circ \bar{\Lambda} \\ \xrightarrow{(q, \psi)} \end{array} (A', h) ,$$

where $\bar{\Lambda}' \circ \bar{\Lambda} = \overline{\mu^h q \circ h \Lambda' \circ \bar{\Lambda}}$. The unit of (p, φ) for this composition is $\overline{\eta^h p} : (p, \varphi) \longrightarrow (p, \varphi)$, since $\eta^h p : p \longrightarrow hp$.

On the other hand, the horizontal structure is given by the following 2-diagram

$$(A, f) \begin{array}{c} \xrightarrow{(p, \varphi)} \\ \downarrow \bar{\Lambda} \\ \xrightarrow{(q, \psi)} \end{array} (A', h) \begin{array}{c} \xrightarrow{(p', \varphi')} \\ \downarrow \bar{\Gamma} \\ \xrightarrow{(q', \psi')} \end{array} (A'', k) = (A, f) \begin{array}{c} \xrightarrow{(p' \cdot p, \varphi' p \circ p' \varphi)} \\ \downarrow \bar{\Gamma} \bar{\Lambda} \\ \xrightarrow{(q' \cdot q, \psi' q \circ q' \psi)} \end{array} (A'', k)$$

where $\bar{\Gamma} \bar{\Lambda} = \overline{\mu^k q' q \circ k \Gamma q \circ \varphi' q \circ p' \Lambda}$ and the unit of (A, f) for this composition is $\overline{\eta^f} : (1_A, 1_f) \longrightarrow (1_A, 1_f)$, since $\eta^f : 1_A \longrightarrow f$. This completes the definition of $\mathbf{KL}(\mathcal{A})$.

2.3.2 Wreaths

The theory of wreaths is developed in [20]. These are considered as *extended distributive laws* and are used in this thesis to get an explicit Kleisli object from any monad on $\mathbf{KL}(\mathcal{A})$. To begin with let us state the following simple

Definition 2.3.2.1. *A wreath is a monad in $\mathbf{KL}(\mathcal{A})$.*

The complete description of a wreath in $\mathbf{KL}(\mathcal{A})$ is the following one. A monad on the object (A, f, μ, η^f) , or a wreath, $((A, f), (h, \lambda), \bar{\nu}, \bar{\sigma})$ consists, according to the previous section, of an endo 1-cell $(h, \lambda) : (A, f) \longrightarrow (A, f)$ and two 2-cells $\bar{\nu} : (h, \lambda) \cdot (h, \lambda) = (h \cdot h, \lambda h \circ h \lambda) \longrightarrow (h, \lambda)$ and $\bar{\sigma} : 1_{(A, f)} \longrightarrow (h, \lambda)$, corresponding to the multiplication and the unit of the wreath, respectively. The previous data has to satisfy the requirements of a monad in $\mathbf{KL}(\mathcal{A})$. More exhaustively, (h, λ) consists of cells $h : A \longrightarrow A$ and $\lambda : hf \longrightarrow fh$ in \mathcal{A} . The last 2-cell satisfies the commutativity of the following diagrams

$$\begin{array}{ccc}
 hff & \xrightarrow{\lambda f} & fhf & \xrightarrow{f\lambda} & ffh \\
 \downarrow h\mu^f & & & & \downarrow \mu^f h \\
 hf & \xrightarrow{\lambda} & fh & & fh
 \end{array} , \quad
 \begin{array}{ccc}
 & h & \\
 h\eta^f \swarrow & & \searrow \eta^f h \\
 hf & \xrightarrow{\lambda} & fh
 \end{array} .$$

The 2-cells in $\mathbf{KL}(\mathcal{A})$, $\bar{\nu}$ and $\bar{\sigma}$, are 2-cells in \mathcal{A} , $\nu : hh \rightarrow fh$ and $\sigma : 1_A \rightarrow fh$, such that the following diagrams commute

$$\begin{array}{ccc}
 hhf & \xrightarrow{h\lambda} & hfh & \xrightarrow{\lambda h} & fhh & \xrightarrow{f\nu} & ffh \\
 \downarrow \nu f & & & & & & \downarrow \mu^f h \\
 fhf & & & & & & fh \\
 \downarrow f\lambda & & & & & & \\
 ffh & \xrightarrow{\mu^f h} & fh & & & & fh
 \end{array} , \quad
 \begin{array}{ccc}
 f & \xrightarrow{f\sigma} & ffh \\
 \downarrow \sigma f & & \downarrow \mu^f h \\
 fhf & & fh \\
 \downarrow f\lambda & & \\
 ffh & \xrightarrow{\mu^f h} & fh
 \end{array} .$$

The requirements for the associativity of the monad and the unitality, $\bar{\nu} \circ \bar{\nu}(h, \lambda) = \bar{\nu} \circ (h, \lambda) \bar{\nu}$ and $\bar{\nu} \circ \bar{\sigma}(h, \lambda) = 1_{(h, \lambda)} = \bar{\nu} \circ (h, \lambda) \bar{\sigma}$, respectively, can be translated to the following commutative diagrams

$$\begin{array}{ccc}
 hhh & \xrightarrow{\nu h} & fhh \\
 \downarrow h\nu & & \downarrow f\nu \\
 hfh & & ffh \\
 \downarrow \lambda h & & \downarrow \mu^f h \\
 fhh & \xrightarrow{f\nu} & ffh & \xrightarrow{\mu^f h} & fh
 \end{array} , \quad
 \begin{array}{ccc}
 h & \xrightarrow{\sigma h} & fhh \\
 \downarrow h\sigma & & \downarrow f\nu \\
 hfh & & ffh \\
 \downarrow \lambda h & & \downarrow \mu^f h \\
 fhh & \xrightarrow{f\nu} & ffh & \xrightarrow{\mu^f h} & fh \\
 & & \eta^f h \searrow & &
 \end{array} .$$

Having a wreath in $\mathbf{KL}(\mathcal{A})$ (0-cell in $\mathbf{KL}(\mathbf{KL}(\mathcal{A}))$), there is an induced composite monad in \mathcal{A} (0-cell in $\mathbf{KL}(\mathcal{A})$), cf. [20], called the *wreath product*. This composite can be seen as the value over 0-cells of the following 2-functor:

$$\mathbf{Comp}_{\mathcal{A}} : \mathbf{KL}(\mathbf{KL}(\mathcal{A})) \longrightarrow \mathbf{KL}(\mathcal{A}) . \quad (2.30)$$

This 2-functor is the left adjoint to the inclusion 2-functor $Inc_{\mathbf{KL}(\mathcal{A})}$. This adjunction is depicted as

$$\mathbf{KL}(\mathbf{KL}(\mathcal{A})) \begin{array}{c} \xleftarrow{Inc_{\mathbf{KL}(\mathcal{A})}} \\ \xrightarrow{\mathbf{Comp}_{\mathcal{A}}} \end{array} \mathbf{KL}(\mathcal{A}) \quad ;$$

see [20]. That $Inc_{\mathbf{KL}(\mathcal{A})}$ has a left adjoint means that $Alg_{\mathbf{KL}(\mathcal{A})} \cong \mathbf{Comp}_{\mathcal{A}}$ and, in particular, $\mathbf{Comp}_{\mathcal{A}}$ has to send a monad $((A, f), (h, \lambda), \bar{\nu}, \bar{\sigma})$ to its Kleisli object, as it was discussed earlier.

The image of the wreath $((A, f), (h, \lambda), \bar{\nu}, \bar{\sigma})$ under the 2-functor $\mathbf{Comp}_{\mathcal{A}}$ can be written down explicitly as (A, fh, μ^c, σ) , where the induced multiplication μ^c for the composite monad is:

$$\mu^c = \mu^f h \circ f \nu \circ \mu^f h h \circ f \lambda h : fhfh \longrightarrow fh . \quad (2.31)$$

Chapter 3

Internal Kleisli Categories

3.1 Monads and Adjunctions in the 2-Category $\mathbf{IntCat}(\mathfrak{M})$

This chapter is based on [10]. In this chapter, Kleisli and coKleisli objects are found in the 2-category of internal categories, that is to say, that the 2-categories $\mathbf{IntCat}^{op}(\mathfrak{M})$ and $\mathbf{IntCat}^{co}(\mathfrak{M})$ admits the construction of algebras. Also, Kleisli objects are found in the 2-category $\mathbf{IntCoCat}(\mathfrak{M})$. In order to do so let us begin by giving the definition of an adjunction in the 2-category $\mathbf{IntCat}(\mathfrak{M})$. Let (A, C) and (B, D) be 0-cells in $\mathbf{IntCat}(\mathfrak{M})$.

Definition 3.1.1. *An adjunction from (A, C) to (B, D) is the data $(l, r, \eta, \varepsilon)$, where l and r are internal functors,*

$$(A, C) \begin{array}{c} \xleftarrow{r} \\ \xrightarrow{l} \end{array} (B, D) \quad , \quad (3.1)$$

and (η, ε) are internal natural transformations,

$$\begin{aligned} \eta & : 1_{(A,C)} \longrightarrow rl \ , \\ \varepsilon & : lr \longrightarrow 1_{(B,D)} \ , \end{aligned}$$

that fulfill the so-called triangular identities:

$$\varepsilon l_0 * l_1 \eta = 1_l \ , \quad (3.3a)$$

$$r_1 \varepsilon * \eta r_0 = 1_r \ . \quad (3.3b)$$

The shorthand notation for such an adjunction is $l \dashv r$, leaving the unit and counit understood.

Remember that according to Section 2.1, the first of the triangular identities will be referred to as the triangular identity associated to the left adjoint l and the second as the triangular identity associated to the right adjoint r , this referencing is by no means standard but it helps a lot when

writing.

Let us rephrase the definition of a monad, given in Section 2.3, but this time within the 2-category $\mathbf{IntCat}(\mathfrak{M})$.

Definition 3.1.2. *A monad on the 0-cell (A, C) consists of the following data (f, μ, η^f) , where the first component is a 1-cell in $\mathbf{IntCat}(\mathfrak{M})$, $f = (f_1, f_0) : (A, C) \longrightarrow (A, C)$ and the rest of the data is composed of 2-cells $\mu : ff \longrightarrow f : (A, C) \longrightarrow (A, C)$ and $\eta^f : 1_{(A, C)} \longrightarrow f : (A, C) \longrightarrow (A, C)$,*

$$\begin{array}{ccc} & ff & \\ & \curvearrowright & \\ (A, C) & \downarrow \mu & (A, C) \\ & \curvearrowleft & \\ & f & \end{array} \quad , \quad \begin{array}{ccc} & 1_A & \\ & \curvearrowright & \\ (A, C) & \downarrow \eta^f & (A, C) \\ & \curvearrowleft & \\ & f & \end{array} \quad ,$$

such that the following diagrams

$$\begin{array}{ccc} fff & \xrightarrow{\mu f_0} & ff \\ f_1 \mu \downarrow & & \downarrow \mu \\ ff & \xrightarrow{\mu} & f \end{array} \quad , \quad \begin{array}{ccc} f & \xrightarrow{\eta^f f_0} & ff \\ f_1 \eta^f \downarrow & \searrow = & \downarrow \mu \\ ff & \xrightarrow{\mu} & f \end{array} \quad , \quad (3.4)$$

commute. The first equation is referred to as the associativity of the monad, and the second one as the unitality of the monad.

Having given the two previous definitions, the following proposition can be stated

Proposition 3.1.3. *Every adjunction $l \dashv r$, from (A, C) to (B, D) , induces a monad on the internal category (A, C) given by*

$$\begin{aligned} f &= rl : (A, C) \longrightarrow (A, C) \quad , \\ \mu &= r_1 \varepsilon l_0 : rlr l \longrightarrow rl \quad , \\ \eta^f &= \eta : 1_{(A, C)} \longrightarrow rl \quad . \end{aligned}$$

Proof :

The first induced map is an endofunctor and the last two are natural transformations due to Section 1.5.3, there remains only to show the associativity and the unitality.

•) Associativity

Translate the associativity condition given in (3.4) by using $f = rl$ and $\mu = r_1 \varepsilon l_0$, then we get the following equality

$$r_1 \varepsilon l_0 * r_1 \varepsilon l_0 r_0 l_0 = r_1 \varepsilon l_0 * r_1 l_1 r_1 \varepsilon l_0 , \quad (3.5)$$

which holds because of the following argument. Use Lemma 1.5.3.2 to factorize r_1 , then the equality that results is the Godement product equality of $\alpha = \varepsilon l_0$ and $\beta = \varepsilon$, like in (1.28).

•) Unitality

Applying r_1 to the triangular identity associated to the left adjoint l and l_0 to the triangular identity associated to the right adjoint r , the following equality can be obtained

$$r_1 \varepsilon l_0 * \eta r_0 l_0 = 1_{rl} = r_1 \varepsilon l_0 * r_1 l_1 \eta . \quad (3.6)$$

This previous equality is nothing but the commutativity of the 2 triangles in the second diagram in (3.4), *i.e.* the unitality of the monad, after translation, using $f = rl$, $\mu = r_1 \varepsilon l_0$ and $\eta^f = \eta$. \square

3.2 Explicit Construction of Kleisli Objects in $\mathbf{IntCat}(\mathfrak{M})$

In this section a Kleisli object is constructed for a given monad in $\mathbf{IntCat}(\mathfrak{M})$. The guideline for this construction is an *ad hoc* variant of the Kleisli category for a monad in a category \mathcal{C} , see Section 2.1. The construction for the coKleisli objects will follow similarly.

3.2.1 Sweedler Notation

This subsection will introduce us to one of the computation methods for a monoidal category used in this thesis. In order to do so, let us introduce first the *Sweedler notation*, cf. [16]. Consider as in Section 1.4.1 a comonoid $(C, \Delta_C, \varepsilon_C)$ in the monoidal category $(\mathbf{Vect}, \otimes, k)$, *i.e.* a coalgebra. Let c be an element in C , then the image of this element under the coaction can be written as $\Delta_C(c) = \sum_{(c)} c_{(1)} \otimes c_{(2)}$. In the previous expression the summation can be left out and the expression can be abbreviated to

$$\Delta_C(c) = c_{(1)} \otimes c_{(2)} ,$$

where the summation is understood. With this notation the coassociativity of the coalgebra can be displayed as

$$(C \otimes \Delta_C) \cdot (\Delta_C)(c) = c_{(1)} \otimes c_{(2)(1)} \otimes c_{(2)(2)} = c_{(1)} \otimes c_{(2)} \otimes c_{(3)} = c_{(1)(1)} \otimes c_{(1)(2)} \otimes c_{(2)} = (\Delta_C \otimes C) \cdot \Delta_C$$

If $(M, {}^C\rho_M, \rho_M^C)$ is a C -comodule for the coalgebra then, for all $m \in M$, the application of the left C -coaction can be written as ${}^C\rho_M(m) = m_{[-1]} \otimes m_{[0]}$, also $\rho_M^C(m) = m_{[0]} \otimes m_{[1]}$. Then, the compatibility condition, for $m \in M$, between these coactions can be written down as

$$m_{[0]_{[-1]}} \otimes m_{[0]_{[0]}} \otimes m_{[1]} = m_{[-1]} \otimes m_{[0]_{[0]}} \otimes m_{[0]_{[1]}} .$$

On the other hand, if (A, m_A, u_A) is a C -ring then, for $a \otimes b \in A \square_C A$, $m_A(a \otimes b) = ab$. The complete details for the Sweedler notation are shown doing calculations.

In [27], the author extends and justifies the use of this notation not only on monoidal categories like $(\mathbf{Vect}, \otimes, k)$, but on general monoidal categories $(\mathfrak{M}, \otimes, I)$, where the objects are not necessarily sets. The role of the elements of a set is played instead by the *generalized elements* of an object A in \mathfrak{M} , which are morphisms $a : X \longrightarrow A$ in \mathfrak{M} . Such a generalized element is referred to as a in A , where any reference to X is omitted.

As an example of the extended Sweedler notation, we list the properties of internal functors and internal natural transformations using generalized elements. Let (A, C) be an internal category in $\mathbf{IntCat}(\mathfrak{M})$. Let also c in C and a, a' in A be generalized elements, then the following lists can be stated.

i) For a functor, $(f_1, f_0) : (A, C) \longrightarrow (B, D)$:

$$\varepsilon_D \cdot f_0(c) = \varepsilon_C(c) \tag{3.7a}$$

$$f_0(c)_{(1)} \otimes f_0(c)_{(2)} = f_0(c_{(1)}) \otimes f_0(c_{(2)}) \tag{3.7b}$$

$$f_1(a)_{[-1]} \otimes f_1(a)_{[0]} = f_0(a_{[-1]}) \otimes f_1(a_{[0]}) \tag{3.7c}$$

$$f_1(a)_{[0]} \otimes f_1(a)_{[1]} = f_1(a_{[0]}) \otimes f_0(a_{[1]}) \tag{3.7d}$$

$$u_B \cdot f_0(c) = f_1 \cdot u_A(c) \tag{3.7e}$$

$$f_1(a)f_1(a') = f_1(aa') \tag{3.7f}$$

ii) For a natural transformation, $\alpha : f \longrightarrow g : (A, C) \longrightarrow (B, D)$:

$$\alpha(c)_{[-1]} \otimes \alpha(c)_{[0]} = g_0(c_{(1)}) \otimes \alpha(c_{(2)}) \tag{3.8a}$$

$$\alpha(c)_{[0]} \otimes \alpha(c)_{[1]} = \alpha(c_{(1)}) \otimes f_0(c_{(2)}) \tag{3.8b}$$

$$g_1(a_{[0]})\alpha(a_{[1]}) = \alpha(a_{[-1]})f_1(a_{[0]}) \tag{3.8c}$$

In the forthcoming calculations to be done with generalized elements, the previous listed properties are important. When an equality in such a calculation uses one of these properties, the use of this property is going to be pointed out as a reference right on the top of the equality itself. Also, in doing calculations, there will not be any reference to obvious manipulations just for the sake of brevity.

3.2.2 Kleisli Objects in $\mathbf{IntCat}(\mathfrak{M})$

3.2.2.1 Construction of the Kleisli objects

The proposal for the Kleisli object in $\mathbf{IntCat}(\mathfrak{M})$, for the monad (f, μ, η^f) over (A, C) , is the following:

- i) The object of objects of the Kleisli object is the same as the object of objects of the internal category (A, C) , according to (2.5). The object of morphisms is defined as $C^f \square_C A$, where the new object of morphisms is modified by the codomain map through the monad f , according to (2.6). Therefore, the proposed internal category that it is the Kleisli object for the monad (f, μ, η^f) is $(C^f \square_C A, C)$, in short notation $A_f = C^f \square_C A$.
- ii) The multiplication $m_f : C^f \square_C A \square_C C^f \square_C A \cong C^f \square_C A^f \square_C A \longrightarrow C^f \square_C A$ is defined as

$$m_f = (C^f \square_C m_A^2) \cdot (C^f \square_C \mu \square_C f_1 \square_C A) \cdot (\iota_f^2 \square_C A) \cdot (\tilde{\Delta}_C^f \square_C A^f \square_C A) , \quad (3.9)$$

which, over a generalized element $c \otimes a_{[0]} \otimes a_{[1]} \otimes a'$ in $C^f \square_C A \square_C C^f \square_C A$, acts as,

$$c \otimes a_{[0]} \otimes a_{[1]} \otimes a' \longmapsto c_{(1)} \otimes \mu(c_{(2)})f_1(a)a' . \quad (3.10)$$

Compare this multiplication with the composition of morphisms in the Kleisli category \mathcal{C}_F , (2.7).

- iii) The unit $u_f : C \longrightarrow C^f \square_C A$ is defined as

$$u_f = (C^f \square_C \eta^f) \cdot \iota_f \cdot \tilde{\Delta}_C , \quad (3.11)$$

which over generalized elements c in C acts as,

$$c \longmapsto c_{(1)} \otimes \eta^f(c_{(2)}) . \quad (3.12)$$

Compare this definition of the unit with the unit morphism for the composition in \mathcal{C}_F , (2.8).

Having defined the proposed Kleisli object for the monad (f, μ, η^f) , the following proposition has to be proved:

Proposition 3.2.2.1.1. *$((C^f \square_C A, C), m_f, u_f)$ is an internal category.*

Proof:

- i) $C^f \square_C A$ is an object in ${}^C\mathcal{M}^C$.

First of all, $C^f \square_C A$ is in ${}^C\mathcal{M}^C$, since its left and right C -comodule structure maps are, $\Delta_C^f \square_C A$, and $C^f \square_C \rho_A^C$, respectively.

ii) m_f is a morphism in ${}^C\mathcal{M}^C$.

Let us prove that the morphism m_f is in ${}^C\mathcal{M}^C$, by proving that all the morphisms related to the definition of it are in ${}^C\mathcal{M}^C$. We begin with $\tilde{\Delta}_C$, which according to Proposition A.4 is a morphism in ${}^C\mathcal{M}^C$, also $\tilde{\Delta}_C^f$ is a morphism in ${}^C\mathcal{M}^C$ since it is the image of the functor F^f and, by the same argument, so is $(1_A)^f = 1_{A^f}$. Therefore $\tilde{\Delta}^f \square_C A^f \square_C A$ is a morphism in ${}^C\mathcal{M}^C$, if we see it as a horizontal composition (coproduct) of morphisms in $\mathbf{Bicomod}(\mathfrak{M})$.

Next, according to Corollary A.5, the morphism ι_f is in ${}^C\mathcal{M}^C$, then so is $\iota_f^2 \square_C A$. By definition, μ and f_1 are morphisms in ${}^C\mathcal{M}^C$, therefore so is $C^f \square_C \mu \square_C f_1 \square_C A$. Also, by definition, m_A is a morphism in ${}^C\mathcal{M}^C$ and, because of this, $C^f \square_C m_A^2$ is a morphism in ${}^C\mathcal{M}^C$ as well. Finally, the composition of these maps, which gives the definition of m_f , is a morphism in ${}^C\mathcal{M}^C$, as required.

Note that the previous argumentation could have been summarized by saying that $\tilde{\Delta}_C$, ι_f , μ , f_1 and m_A are morphisms in ${}^C\mathcal{M}^C$, then take a suitable combination of vertical and horizontal compositions in $\mathbf{Bicomod}(\mathfrak{M})$ to obtain the morphism m_f . Note that this combination is inside the monoidal category $({}^C\mathcal{M}^C, \square_C, C)$ which is obtained from the bicategory $\mathbf{Bicomod}(\mathfrak{M})$ by fixing the comonoid $(C, \Delta_C, \varepsilon_C)$, see Remark 1.5.1.1.

iii) u_f is a morphism in ${}^C\mathcal{M}^C$

According to the previous paragraphs $\tilde{\Delta}_C$ and ι_f are morphisms in ${}^C\mathcal{M}^C$, also, by definition, η^f is a morphism in ${}^C\mathcal{M}^C$, therefore u_f is a morphism in ${}^C\mathcal{M}^C$, as required.

iv) m_f is associative.

Let $c \otimes a_{[0]} \otimes a_{[1]} \otimes a'_{[0]} \otimes a'_{[1]} \otimes a''$ be a generalized element in $C^f \square_C A \square_C C^f \square_C A \square_C C^f \square_C A$, then

$$\begin{aligned}
(m_f \cdot (C^f \square_C A \square_C m_f))(c \otimes a_{[0]} \otimes a_{[1]} \otimes a'_{[0]} \otimes a'_{[1]} \otimes a'') &= c_{(1)} \otimes \mu(c_{(2)}) f_1(a_{[0]}) \mu(a_{[1]}) f_1(a') a'' \\
&\stackrel{3.8c}{=} c_{(1)} \otimes \mu(c_{(2)}) \mu(a_{[-1]}) f_1 f_1(a_{[0]}) f_1(a') a'' \\
&= c_{(1)} \otimes \mu(c_{(2)}) \mu f_0(c_{(3)}) f_1 f_1(a) f_1(a') a'' \\
&= c_{(1)} \otimes \mu(c_{(2)}) f_1 \mu(c_{(3)}) f_1 f_1(a) f_1(a') a'' \\
&\stackrel{3.7f}{=} c_{(1)} \otimes \mu(c_{(2)}) f_1 [\mu(c_{(3)}) f_1(a) a'] a'' \\
&= (m_f \cdot (m_f \square_C C^f \square_C A))(c \otimes a_{[0]} \otimes a_{[1]} \otimes a'_{[0]} \otimes a'_{[1]} \otimes a'').
\end{aligned}$$

In the third equality, the fact that $c \otimes a$ is a generalized element in $C^f \square_C A$, *i.e.* $c \otimes a_{[-1]} \otimes a_{[0]} = c_{(1)} \otimes f_0(c_{(2)}) \otimes a$, was used and in the fourth one, the associativity of the monad, *i.e.* $\mu * \mu f_0 = \mu * f_1 \mu$. The sixth equality follows from the right C -colinearity of m_A .

v) u_f is unital.

Let $c \otimes a$ be a generalized element in $C^f \square_C A$, then

$$\begin{aligned}
m_f \cdot (A_f \square_C u_f)(c \otimes a) &= c_{(1)} \otimes \mu(c_{(2)})f_1(a_{[0]})\eta^f(a_{[1]}) \\
&\stackrel{3.8c}{=} c_{(1)} \otimes \mu(c_{(2)})\eta^f(a_{[-1]})a_{[0]} \\
&= c_{(1)} \otimes \mu(c_{(2)})\eta^f f_0(c_{(3)})a \\
&= c_{(1)} \otimes u_A f_0(c_{(2)})a \\
&= c \otimes u_A(a_{[-1]})a_{[0]} \\
&= c \otimes a.
\end{aligned}$$

In the third and fifth equality, the fact that $c \otimes a$ is a generalized element in $C^f \square_C A$ was used, and in the fourth one, the unitality of the monad, *i.e.* $\mu * \eta^f f_0 = 1_f$. In the sixth equality, the unitality of u_A was applied. On the other hand,

$$\begin{aligned}
m_f \cdot (u_f \square_C A_f)(c \otimes a) &= c_{(1)} \otimes \mu(c_{(2)})f_1\eta^f(c_{(3)})a \\
&= c_{(1)} \otimes u_A f_0(c_{(2)})a \\
&= c_{(1)} \otimes u_A(a_{[-1]})a_{[0]} \\
&= c \otimes a.
\end{aligned}$$

Here there is nothing more to add other than the unitality of the monad $\mu * f_1 \eta^f = 1_f$ was used in the second equality. \square

Let us propose the f -adjunction of the Kleisli object (A_f, C) over the internal category (A, C) .

For the left adjoint functor $l : (A, C) \longrightarrow (A_f, C)$ the following pair of morphisms is proposed:
 $l_0 : C \longrightarrow C$ as

$$l_0 = Id_C, \quad (3.13)$$

and $l_1 : A \longrightarrow A_f$ as

$$l_1 = (C^f \square_C m_A) \cdot (C^f \square_C \eta^f \square_C A) \cdot (\iota_f \square_C A) \cdot (\tilde{\Delta}_C \square_C A) \cdot C\tilde{\rho}_A. \quad (3.14)$$

Here the reader is compelled to check on the definition of the left adjoint functor for the Kleisli object in (2.12). This last morphism acts upon generalized elements as

$$a \longmapsto a_{[-1](1)} \otimes \eta^f(a_{[-1](2)})a_{[0]}. \quad (3.15)$$

As for the right adjoint functor $r : (A_f, C) \longrightarrow (A, C)$ the following pair of maps is proposed:
 $r_0 : C \longrightarrow C$,

$$r_0 = f_0 , \quad (3.16)$$

and $r_1 : A_f \longrightarrow A$

$$r_1 = m_A \cdot (\mu \square_C f_1) \cdot \iota_f , \quad (3.17)$$

a morphism which acts upon generalized elements as

$$c \otimes a \longmapsto \mu(c) f_1(a) . \quad (3.18)$$

These definitions should be compared to the definition of the right adjoint functor for the Kleisli category, (2.13).

Before giving the unit and counit of the adjunction, let us prove the following

Proposition 3.2.2.1.2. *The pairs of morphisms l and r between internal categories (A, C) and (A_f, C) , just defined, are indeed functors.*

Proof:

i) l_0 is a morphism in $\mathbf{Comon}_{\mathfrak{M}}$ obviously.

ii) $l_1 : {}^l A^l \rightarrow A_f$ is in ${}^C \mathcal{M}^C$.

Since l_0 is the identity comonoid morphism, ${}^l A^l = A$. The morphism ${}^C \tilde{\rho}_A$ is in ${}^C \mathcal{M}^C$, according to Proposition A.4, since ${}^C \rho_A$ is a fork for the cotensor product $C \square_C A$. The rest of the morphisms involved in the definition of l_1 have already been proved to be in ${}^C \mathcal{M}^C$.

iii) Multiplicativity of l_1 , *i.e.* the following diagram commutes

$$\begin{array}{ccc} A \square_C A & \xrightarrow{l_1 \square_C l_1} & C^f \square_C A \square_C C^f \square_C A \\ \downarrow m_A & & \downarrow m_f \\ A & \xrightarrow{l_1} & C^f \square_C A \end{array} .$$

Let $a \otimes a'$ be a generalized element in $A \square_C A$, then

$$\begin{aligned}
m_f \cdot (l_1 \square_C l_1)(a \otimes a') &= m_f(a_{[-1](1)} \otimes \eta^f(a_{[-1](2)})a_{[0]} \otimes a'_{[-1](1)} \otimes \eta^f(a'_{[-1](2)})a'_{[0]}) \\
&= m_f(a_{[0]([-1](1))} \otimes \eta^f(a_{[0]([-1](2))})a_{[0][0]} \otimes a_{1} \otimes \eta^f(a_{[1](2)})a') \\
&= a_{[0]([-1](1)(1))} \otimes \mu(a_{[0]([-1](1)(2))})f_1(\eta^f(a_{[0]([-1](2))})a_{[0][0]})\eta^f(a_{[1]})a' \\
&= a_{[0]([-1](1))} \otimes \mu(a_{[0]([-1](2)(1))})f_1(\eta^f(a_{[0]([-1](2)(2))}))f_1(a_{[0][0]})\eta^f(a_{[1]})a' \\
&= a_{[0]([-1](1))} \otimes u_A f_0(a_{[0]([-1](2))})f_1(a_{[0][0]})\eta^f(a_{[1]})a' \\
&= a_{[-1](1)} \otimes u_A f_0(a_{[-1](2)})f_1(a_{[0][0]})\eta^f(a_{[0][1]})a' \\
&\stackrel{3.8c}{=} a_{[-1](1)} \otimes u_A f_0(a_{[-1](2)})\eta^f(a_{[0]([-1])})a_{[0][0]}a' \\
&= a_{[-1](1)} \otimes u_A f_0(a_{[-1](2)(1)})\eta^f(a_{[-1](2)(2)})a_{[0]}a' \\
&\stackrel{3.8a}{=} a_{[-1](1)} \otimes u_A(\eta^f(a_{[-1](2)})_{[-1]})\eta^f(a_{[-1](2)})_{[0]}a_{[0]}a' \\
&= a_{[-1](1)} \otimes \eta^f(a_{[-1](2)})a_{[0]}a' \\
&= (aa')_{[-1](1)} \otimes \eta^f((aa')_{[-1](2)})(aa')_{[0]} \\
&= l_1 \cdot m_A(a \otimes a') .
\end{aligned}$$

In the second equality, the fact that $a \otimes a'$ is a generalized element in $A \square_C A$, *i.e.* $a_{[0]} \otimes a_{[1]} \otimes a' = a \otimes a'_{[-1]} \otimes a'_{[0]}$ was used. In the third equality, the right C -colinearity of m_A was applied along with the compatibility of coactions for A and the coassociativity of the right C -coaction of A . In the fourth equality, the coassociativity of Δ_C and the multiplicativity of f_1 were used. The fifth equality follows by the unitality of the monad, *i.e.* $\mu * f_1 \eta^f = 1_f$. The sixth one is a consequence of the compatibility of the left and right C -coactions of A . In the eighth one, that ${}^C\rho_A$ is a left C -coaction for A and the coassociativity of Δ_C were used. In the tenth equality, the unitality of u_A was used. The final equality, follows by the fact that m_A is a morphism in ${}^C\mathcal{M}$.

iv) Compatibility of units, *i.e.* the following diagram commutes,

$$\begin{array}{ccc}
C & \xrightarrow{l_0} & C \\
u_A \downarrow & & \downarrow u_f \\
A & \xrightarrow{l_1} & A_f
\end{array} .$$

Let c be a generalized element in C , then

$$\begin{aligned}
u_f \cdot l_0(c) &= c_{(1)} \otimes \eta^f(c_{(2)}) \\
&= c_{(1)} \otimes \eta^f(c_{(2)})_{[0]}u_A(\eta^f(c_{(2)}))_{[1]} \\
&\stackrel{3.8b}{=} c_{(1)} \otimes \eta^f(c_{(2)(1)})u_A(c_{(2)(2)}) \\
&= c_{(1)(1)} \otimes \eta^f(c_{(1)(2)})u_A(c_{(2)}) \\
&= u_A(c)_{[-1](1)} \otimes \eta^f(u_A(c)_{[-1](2)})u_A(c)_{[0]} \\
&= l_1 \cdot u_A(c) .
\end{aligned}$$

In the second equality, the unitality of u_A was applied and in the fourth one, the coassociativity of Δ_C . And finally, the fifth equality is a consequence of the fact that u_A is a morphism in ${}^C\mathcal{M}$, *i.e.* $u_A(c)_{[-1]} \otimes u_A(c)_{[0]} = c_{(1)} \otimes u_A(c_{(2)})$.

i') r_0 is a morphism in $\mathbf{Comon}_{\mathfrak{M}}$ by definition.

ii') $r_1 : {}^rA_f^r \rightarrow A$ is a morphism in ${}^C\mathcal{M}^C$.

According to Corollary A.5, the morphism ι_f is in ${}^C\mathcal{M}^C$, and because of the functor ${}^fF^f$, so is ${}^f\iota_f^f : {}^fC^f \square_C A^f \rightarrow {}^fC^{ff} \square_C {}^fA^f$. It was already check that μ , f_1 and m_A are morphisms in ${}^C\mathcal{M}^C$, therefore $r_1 : {}^rA_f^r \rightarrow A$ is a morphism in ${}^C\mathcal{M}^C$, since it is a combination of compositions of morphisms in ${}^C\mathcal{M}^C$.

Note the difference between proving that $r_1 : {}^rA_f^r \rightarrow A$ is a morphism in ${}^C\mathcal{M}^C$ from $r_1 : A_f \rightarrow A$ being a morphism in ${}^C\mathcal{M}^C$, this difference comes from the definition of an internal functor in Definition 1.4.2.1.

iii') Multiplicativity of r_1 , *i.e.* the following diagram commutes

$$\begin{array}{ccc}
 C^f \square_C A \square_C C^f \square_C A & \xrightarrow{\iota_f} & C^f \square_C A^f \square_C {}^fC^f \square_C A \xrightarrow{r_1 \square_C r_1} A \square_C A \\
 \downarrow m_f & & \downarrow m_A \\
 C^f \square_C A & \xrightarrow{r_1} & A
 \end{array} .$$

Let $c \otimes a_{[0]} \otimes a_{[1]} \otimes a'$ be a generalized element in $C^f \square_C A \square_C C^f \square_C A$, then

$$\begin{aligned}
 (m_f \cdot (r_1 \square_C r_1) \cdot \iota_f)(c \otimes a_{[0]} \otimes a_{[1]} \otimes a') &\stackrel{3.18}{=} \mu(c) f_1(a_{[0]}) \mu(a_{[1]}) f_1(a') \\
 &\stackrel{3.8c}{=} \mu(c) \mu(a_{[-1]}) f_1 f_1(a_{[0]}) f_1(a') \\
 &= \mu(c_{(1)}) \mu f_0(c_{(2)}) f_1 f_1(a) f_1(a') \\
 &= \mu(c_{(1)}) f_1 \mu(c_{(2)}) f_1 f_1(a) f_1(a') \\
 &= r_1 \cdot m_f(c \otimes a_{[0]} \otimes a_{[1]} \otimes a') .
 \end{aligned}$$

In the third equality, the fact that $c \otimes a$ is a generalized element in $C^f \square_C A$, *i.e.* $c_{(1)} \otimes f_0(c_{(2)}) \otimes a = c \otimes a_{[-1]} \otimes a_{[0]}$ was used, and in the fourth equality, the associativity of the monad was used.

iv') Compatibility of units, *i.e.* the following diagram commutes,

$$\begin{array}{ccc}
 C & \xrightarrow{r_0} & C \\
 \downarrow u_f & & \downarrow u_A \\
 A_f & \xrightarrow{r_1} & A
 \end{array} .$$

Let c be a generalized element in C , then

$$\begin{aligned} u_A \cdot r_0(c) &= u_A f_0(c) \\ &= \mu(c_{(1)}) f_1 \eta^f(c_{(2)}) \\ &= r_1 \cdot u_f(c) , \end{aligned}$$

where only the unitality of the monad was required. \square

Now that the proof has been given, the adjunction can be formulated by giving the unit and counit of it. For a unit of the f -adjunction, a natural transformation

$$\eta^K : 1_{(A,C)} \longrightarrow rl,$$

is needed. The composition rl will give:

$$\begin{aligned} r_0 \cdot l_0 &= f_0 \cdot 1_C = f_0 , \\ r_1 \cdot l_1(a) &= r_1(a_{[-1](1)} \otimes \eta^f(a_{[-1](2)})a_{[0]}) \\ &= \mu(a_{[-1](1)}) f_1 \eta^f(a_{[-1](2)}) f_1(a_{[0]}) \\ &= f_1 u_A(a_{[-1]}) f_1(a_{[0]}) \\ &= f_1(u_A(a_{[-1]})a_{[0]}) \\ &= f_1(a) , \end{aligned}$$

where the unitality of the monad was required in the third equality and the unitality of u_A in the fifth one. Therefore, $rl = f$ and the unit can be defined as

$$\eta^K = \eta^f . \tag{3.19}$$

For a counit, a natural transformation

$$\varepsilon^K : lr \longrightarrow 1_{(A_f,C)} ,$$

is needed. The composition lr is the following:

$$\begin{aligned}
l_0 \cdot r_0 &= f_0 , \\
l_1 \cdot r_1(c \otimes a) &= l_1(\mu(c)f_1(a)) \\
&= (\mu(c)f_1(a))_{[-1](1)} \otimes \eta^f((\mu(c)f_1(a))_{[-1](2)}) (\mu(c)f_1(a))_{[0]} \\
&= \mu(c)_{[-1](1)} \otimes \eta^f(\mu(c)_{[-1](2)}) \mu(c)_{[0]} f_1(a) \\
&\stackrel{3.8a}{=} f_0(c_{(1)})_{(1)} \otimes \eta^f(f_0(c_{(1)})_{(2)}) \mu(c_{(2)}) f_1(a) \\
&= f_0(c)_{(1)} \otimes \eta^f(f_0(c)_{(2)}) \mu(c_{(3)}) f_1(a) .
\end{aligned}$$

The third equality follows by the hypothesis that m_A is a morphism in ${}^C\mathcal{M}$, *i.e.* for a generalized element $b \otimes b'$ in $A \square_C A$, $(bb')_{[-1](1)} \otimes (bb')_{[-1](2)} \otimes (bb')_{[0]} = b_{[-1](1)} \otimes b_{[-1](2)} \otimes b_{[0]} b'$. In the fifth equality, the fact that f_0 is a morphism of comonoids was used.

Let us now define the counit $\varepsilon^K : C \longrightarrow C^f \square_C A$ as

$$\varepsilon^K = (C^f \square_C f_1) \cdot \iota_f \cdot (C^f \square_C u_A) \cdot \tilde{\Delta}_C . \quad (3.20)$$

This morphism acts over a generalized element c in C , as

$$c \longmapsto c_{(1)} \otimes f_1 u_A(c_{(2)}) . \quad (3.21)$$

Proposition 3.2.2.1.3. *The morphism ε^K , previously defined, is a natural transformation from lr to $1_{(A_f, C)}$*

Proof:

i) The morphism $\varepsilon^K : C^f \longrightarrow C^f \square_C A$ is in ${}^C\mathcal{M}^C$.

Since the composite morphism $\iota_f \cdot (C^f \square_C u_A) \cdot \tilde{\Delta}_C$ is in ${}^C\mathcal{M}^C$, hence if the functor F^f is applied to it

$$F^f(\iota_f \cdot (C^f \square_C u_A) \cdot \tilde{\Delta}_C) = \iota_f^f \cdot (C^f \square_C u_A^f) \cdot \tilde{\Delta}_C^f ,$$

the resulting morphism is in ${}^C\mathcal{M}^C$ as well. On the other hand, the morphism $C^f \square_C f_1 : C^f \square_C f_1 A^f \longrightarrow C^f \square_C A$ is in ${}^C\mathcal{M}^C$, therefore the composition of this two maps that gives ε^K is in ${}^C\mathcal{M}^C$.

ii) Naturality of the counit, *i.e.* the following diagram commutes

$$\begin{array}{ccccc}
& & C^f \square_C A \square_C C & \xrightarrow{\iota_C} & C^f \square_C A \square_C C & \xrightarrow{C^f \square_C A \square_C \varepsilon^K} & C^f \square_C A \square_C C^f \square_C C & & \\
& \nearrow^{C^f \square_C \rho_A^C} & & & & & & \searrow^{m_f} & \\
C^f \square_C A & & & & & & & & C^f \square_C A . \\
& \searrow_{\tilde{\Delta}_C \square_C A} & & & & & & \nearrow_{m_f} & \\
& & C \square_C C^f \square_C A & \xrightarrow{\iota_f \square_C A} & C^f \square_C C^f \square_C A & \xrightarrow{\varepsilon^K \square_C l_1 r_1} & C^f \square_C A \square_C C^f \square_C C & &
\end{array}$$

Let $c \otimes a$ be a generalized element in $C^f \square_C A$, then

$$\begin{aligned}
(m_f \cdot (C^f \square_C A \square_C \varepsilon^K) \cdot (C^f \square_C \rho_A^C))(c \otimes a) &= m_f(c \otimes a_{[0]} \otimes a_{1} \otimes f_1 u_A(a_{[1](2)})) \\
&= c_{(1)} \otimes \mu(c_{(2)}) f_1(a_{[0]}) f_1 u_A(a_{[1]}) \\
&= c_{(1)} \otimes \mu(c_{(2)}) f_1(a) \\
&= c_{(1)} \otimes u_A(\mu(c_{(2)})_{[-1]}) \mu(c_{(2)})_{[0]} f_1(a) \\
&\stackrel{3.8a}{=} c_{(1)} \otimes u_A f_0(c_{(2)}) \mu(c_{(3)}) f_1(a) \\
&= c_{(1)} \otimes \mu(c_{(2)}) \eta^f f_0(c_{(3)}) \mu(c_{(4)}) f_1(a) \\
&= c_{(1)} \otimes \mu(c_{(2)})_{[0]} u_A(\mu(c_{(2)})_{[1]}) \eta^f f_0(c_{(3)}) \mu(c_{(4)}) f_1(a) \\
&\stackrel{3.8b}{=} c_{(1)} \otimes \mu(c_{(2)}) u_A f_0 f_0(c_{(3)}) \eta^f f_0(c_{(4)}) \mu(c_{(5)}) f_1(a) \\
&= c_{(1)} \otimes \mu(c_{(2)}) f_1 f_1 u_A(c_{(3)}) \eta^f f_0(c_{(4)}) \mu(c_{(5)}) f_1(a) \\
&= m_f(c_{(1)} \otimes f_1 u_A(c_{(2)}) \otimes f_0(c_{(3)}) \otimes \eta^f f_0(c_{(4)}) \mu(c_{(5)}) f_1(a)) \\
&= m_f \cdot (\varepsilon^K \square_C l_1 r_1) \cdot (\iota_f \square_C A) \cdot (\tilde{\Delta}_C \square_C A)(c \otimes a) .
\end{aligned}$$

In the second, fourth and seventh equalities, the unitality of u_A was required. In the sixth equality, the unitality of the monad was used instead. In the ninth equality, the right C -colinearity of u_A was applied. \square

In the previous calculation there is an equality that we want to single out for further references. Let c be a generalized element in C , then

$$\begin{aligned}
u_A f_0(c) &= \mu(c_{(1)}) \eta^f f_0(c_{(2)}) \\
&= \mu(c_{(1)})_{[0]} u_A(\mu(c_{(1)})_{[1]}) \eta^f f_0(c_{(2)}) \\
&= \mu(c_{(1)}) u_A f_0 f_0(c_{(2)}) \eta^f f_0(c_{(3)}) \\
&= \mu(c_{(1)}) f_1 f_1 u_A(c_{(2)}) \eta^f f_0(c_{(3)}) .
\end{aligned} \tag{3.22}$$

Once that the naturality of the counit has been proved, only the triangular identities are left to be proved:

$$\text{i) } \varepsilon^K l_0 * l_1 \eta^K = u_f l_0,$$

Let c be a generalized element in C , then

$$\begin{aligned} \varepsilon^K l_0 * l_1 \eta^K(c) &= m_f(\varepsilon^K l_0(c_{(1)}) \otimes l_1 \eta^K(c_{(2)})) \\ &= m_f(c_{(1)} \otimes f_1 u_A(c_{(2)}) \otimes (\eta^f(c_{(3)})_{[-1](1)} \otimes \eta^f(\eta^f(c_{(3)})_{[-1](2)}) \eta^f(c_{(3)})_{[0]}) \\ &\stackrel{3.8a}{=} m_f(c_{(1)} \otimes f_1 u_A(c_{(2)}) \otimes f_0(c_{(3)}) \otimes \eta^f f_0(c_{(4)}) \eta^f(c_{(5)})) \\ &= c_{(1)} \otimes \mu(c_{(2)}) f_1 f_1 u_A(c_{(3)}) \eta^f f_0(c_{(4)}) \eta^f(c_{(5)}) \\ &= c_{(1)} \otimes u_A f_0(c_{(2)}) \eta^f(c_{(3)}) \\ &\stackrel{3.8a}{=} c_{(1)} \otimes u_A(\eta^f(c_{(2)})_{[-1]}) \eta^f(c_{(2)})_{[0]} \\ &= c_{(1)} \otimes \eta^f(c_{(2)}) \\ &= u_f l_0(c) . \end{aligned}$$

In the fifth equality, the equality given in (3.22) was used.

$$\text{ii) } r_1 \varepsilon^K * \eta^K r_0 = u_A r_0,$$

Let c be a generalized element in C ,

$$\begin{aligned} (r_1 \varepsilon^K * \eta^K r_0)(c) &= m_A(r_1 \varepsilon^K(c_{(1)}) \otimes \eta^K r_0(c_{(2)})) \\ &= \mu(c_{(1)}) f_1 f_1 u_A(c_{(2)}) \eta^f f_0(c_{(3)}) \\ &= u_A f_0(c) \\ &= u_A r_0(c) . \end{aligned}$$

In the third equality, (3.22) was used.

Just as in the case of standard categories, see Proposition 2.1.1, the following can be stated.

Proposition 3.2.2.1.4. *The monad induced by the adjunction*

$$(A, C) \begin{array}{c} \xleftarrow{r} \\ \xrightarrow{l} \end{array} (C^f \square_C A, C) \quad ,$$

is the monad which the construction of the Kleisli object started with, i.e. (f, μ, η^f) .

Proof:

$$\text{i) } f = rl, \text{ as already explained it follows immediately from the construction of functors } r \text{ and } l.$$

$$\text{ii) } \mu = r_1 \varepsilon^K l_0 .$$

Let c be a generalized element in C , then

$$r_1 \varepsilon^K l_0(c) = \mu(c_{(1)}) f_1 f_1 u_A(c_{(2)}) = \mu(c_{(1)}) u_A f_0 f_0(c_{(2)}) \stackrel{3.8b}{=} \mu(c)_{[0]} u_A(\mu(c)_{[1]}) = \mu(c) .$$

In the last equation, the unitality of u_A was applied.

$$\text{iii) } \eta^f = \eta^K, \text{ by definition.} \quad \square$$

3.2.2.2 Proof for the Kleisli Object

The previous section dealt with the construction of the *a posteriori* Kleisli object for the monad (f, μ, η^f) over (A, C) in $\mathbf{IntCat}(\mathfrak{M})$, and with its well-defined construction, *i.e.* that it is an internal category and the induced monad over (A, C) is precisely the one we started with. In this section, the proof that this internal category is indeed a Kleisli object is given by showing the isomorphism of categories required in [24], through the representation of Alg_F , see (2.25).

According to the isomorphism of categories given by (2.25), the following 2-cell in the 2-category $\mathbf{2-Cat}$ can be constructed

$$\begin{array}{ccc} & Alg_F & \\ & \curvearrowright & \\ \mathbf{IntCat}(\mathfrak{M}) & \downarrow \cong \Theta & \mathbf{2Cat} , \\ & \curvearrowleft & \\ & \mathbf{IntCat}((A_f, C), _) & \end{array}$$

where the following substitutions were made in (2.25) : $\mathcal{A} = \mathbf{IntCat}(\mathfrak{M})$ and $A_K = (C^f \square_C A, C)$. Let (B, D) be in $\mathbf{IntCat}(\mathfrak{M})$, then

$$\Theta_{(B,D)} : Alg_F(B, D) \longrightarrow \mathbf{IntCat}((C^f \square_C A, C), (B, D)),$$

is a 1-cell in $\mathbf{2Cat}$, that it is to say, a functor, and is defined

i) on objects (s, σ) in $Alg_F(B, D) = (B, D)_F$ as,

$$\begin{aligned} (\Theta_{(B,D)}(s, \sigma))_0 &= s_0 , \\ (\Theta_{(B,D)}(s, \sigma))_1 &= m_B \cdot (\sigma \square_D s_1) \cdot \iota_s ; \end{aligned}$$

ii) on morphisms $\bar{\Sigma} : (s, \sigma) \longrightarrow (t, \tau)$,

$$\Theta_{(B,D)}(\overrightarrow{\Sigma}) = \overrightarrow{\Sigma} \ .$$

where the notation $\overrightarrow{\Sigma}$ means that the underlying morphism $\Sigma : s \longrightarrow t$ is the same but it has to fulfill different requirements.

The proposal for the inverse natural transformation $\tilde{\Theta}$ is defined as follows.

i') On objects $g = (g_1, g_0)$ in $\mathbf{IntCat}((C^f \square_C A, C), (B, D))$ as,

$$\begin{aligned} (\tilde{\Theta}_{(B,D)}(g_1, g_0)_s)_0 &= g_0 l_0 \ , \\ (\tilde{\Theta}_{(B,D)}(g_1, g_0)_s)_1 &= g_1 l_1 \ , \\ \tilde{\Theta}_{(B,D)}(g_1, g_0)_\sigma &= g_1 \varepsilon^K l_0 \ . \end{aligned}$$

ii') On morphisms $\beta : (g_1, g_0) \longrightarrow (g'_1, g'_0)$,

$$\tilde{\Theta}_{(B,D)}(\beta) = \beta l_0 \ .$$

Having defined the 2-natural transformation Θ and its expected inverse $\tilde{\Theta}$, we need to prove the following

Proposition 3.2.2.2.1. *The 2-natural transformations Θ and $\tilde{\Theta}$ are well-defined.*

Proof:

For Θ :

i) On objects, the pair $((\Theta_{(B,D)}(s, \sigma))_1, (\Theta_{(B,D)}(s, \sigma))_0)$ is an internal functor.

Since $s : (A, C) \longrightarrow (B, D)$ is already a functor then $s_0 : C \longrightarrow D$ is a morphism in $\mathbf{Comon}_{\mathfrak{M}}$. On the other hand, we need to establish that $m_B \cdot (\sigma \square_C s_1) \cdot \iota_s$ is part of an internal functor:

- $m_B \cdot (\sigma \square_C s_1) \cdot \iota_s : {}^s C^f \square_C A^s \longrightarrow B$ is a morphism in ${}^D \mathcal{M}^D$.

First, ι_s is a morphism in ${}^C \mathcal{M}^C$, then after applying the induced functor ${}^s F^s, {}^s \iota_s^s$ will be a morphism in ${}^D \mathcal{M}^D$. Second, $\sigma : {}^s C^{sf} \longrightarrow B$, $s_1 : {}^s A^s \longrightarrow B$ and $m_B : B \square_D B \longrightarrow B$ are morphisms in ${}^D \mathcal{M}^D$ by hypothesis, therefore the composite $m_B \cdot (\sigma \square_C s_1) \cdot \iota_s$ is in ${}^D \mathcal{M}^D$, as required.

- The morphism $m_B \cdot (\sigma \square_C s_1) \cdot \iota_s$ is multiplicative.

The proof of this multiplicativity is done with generalized elements and using the Sweedler notation as before. Let $c \otimes a_{[0]} \otimes a_{[1]} \otimes a'$ be a generalized element in $C^f \square_C A \square_C C^f \square_C A$, then

$$\begin{aligned}
& \left(m_B \cdot ((m_B \cdot (\sigma \square_C s_1) \cdot \iota_s) \square_D (m_B \cdot (\sigma \square_C s_1) \cdot \iota_s)) \cdot (C^f \square_C \iota_s \square_C A) \right) (c \otimes a_{[0]} \otimes a_{[1]} \otimes a') \\
&= \sigma(c) s_1(a_{[0]}) \sigma(a_{[1]}) s_1(a') \\
&\stackrel{3.8c}{=} \sigma(c) \sigma(a_{[-1]}) s_1 f_1(a_{[0]}) s_1(a') \\
&= \sigma(c_{(1)}) \sigma(f_0(c_{(2)})) s_1 f_1(a) s_1(a') \\
&= \sigma(c_{(1)}) s_1 \mu(c_{(2)}) s_1 f_1(a) s_1(a') \\
&= ((m_B \cdot (\sigma \square_C s_1) \cdot \iota_s) \cdot m_f) (c \otimes a_{[0]} \otimes a_{[1]} \otimes a') .
\end{aligned}$$

In the third equality, the fact that the generalized element $c \otimes a$ is in $C^f \square_C A$, *i.e.* $c_{(1)} \otimes f_0(c_{(2)}) \otimes a = c \otimes a_{[-1]} \otimes a_{[0]}$, was used. The fourth equality follows from the requirement given by the first diagram in (2.27), for an object in $(B, D)_F$.

- Compatibility with units.

Let c be a generalized element in C , then

$$u_B s_0(c) = 1_s(c) = \sigma(c_{(1)}) s_1 \eta^f(c_{(2)}) = ((m_B \cdot (\sigma \square_C s_1) \cdot \iota_s) \cdot u_f)(c) .$$

In the second equality, the second requirement in (2.27), for an object in $(B, D)_F$, was used.

- ii) On morphisms, $\Theta_{(B,D)}(\overline{\Sigma})$ is an internal natural transformation.

The proof of the naturality of $\overrightarrow{\Sigma}: m_B \cdot (\sigma \square_C s_1) \cdot \iota_s \longrightarrow m_B \cdot (\sigma' \square_C s'_1) \cdot \iota_{s'}$ is split into the following two parts:

- $\Sigma: s'^C \longrightarrow B$ is in ${}^D\mathcal{M}^D$, which follows from the definition of $\overline{\Sigma}: s \longrightarrow s'$ being a natural transformation.
- The naturality of $\overrightarrow{\Sigma}$.

Let $c \otimes a$ be a generalized element in $C^f \square_C A$, then

$$\begin{aligned}
& \left(m_B \cdot ((m_B \cdot (\sigma' \square_C s'_1) \cdot \iota_{s'}) \square_D \Sigma) \cdot (C^f \square_C \iota_{s'}) \cdot (C^f \square_C \tilde{\rho}_A^C) \right) (c \otimes a) = \sigma'(c) s'_1(a_{[0]}) \Sigma(a_{[1]}) \\
&\stackrel{3.8c}{=} \sigma'(c) \Sigma(a_{[-1]}) s_1(a_{[0]}) \\
&= \sigma'(c_{(1)}) \Sigma f_0(c_{(2)}) s_1(a) \\
&= \Sigma(c_{(1)}) \sigma(c_{(2)}) s_1(a) \\
&= (m_B \cdot (\Sigma \square_D (m_B \cdot (\sigma \square_C s_1) \cdot \iota_s)) \cdot (\iota_s \square_C A) \cdot (\tilde{\Delta}_C^f \square_C A)) (c \otimes a) .
\end{aligned}$$

In the third equality, the requirement (2.29), *i.e.* $\Sigma * \sigma = \sigma' * \Sigma f_0$, was used.

For $\tilde{\Theta}$:

- i) On objects (g_1, g_0) in $\mathbf{IntCat}((A_f, C), (B, D))$; $(\tilde{\Theta}_{(B,D)}(g_1, g_0)_s, \tilde{\Theta}_{(B,D)}(g_1, g_0)_\sigma)$ is an object in $(B, D)_F$.

Clearly, $\tilde{\Theta}_{(B,D)}(g_1, g_0)_s = gl$ is a functor from (A, C) to (B, D) , and $\tilde{\Theta}_{(B,D)}(g_1, g_0)_\sigma$ a natural transformation from $glf = glrl$ to gl . As far as the requirements in (2.27) are concerned, they are translated into the following requirements, taking into account that $\mu = r_1 \varepsilon^K l_0$,

- $g_1 \varepsilon^K l_0 * g_1 l_1 r_1 \varepsilon^K l_0 = g_1 \varepsilon^K l_0 * g_1 \varepsilon^K l_0 r_0 l_0$.

Due to Lemma (1.5.3.2), it is enough to prove the equality $\varepsilon^K l_0 * l_1 r_1 \varepsilon^K l_0 = \varepsilon^K l_0 * \varepsilon^K l_0 r_0 l_0$, but this equality is just the Godement product equality for $\varepsilon^K \bar{*} \varepsilon^K l_0$.

- $g_1 \varepsilon^K l_0 * g_1 l_1 \eta^K = 1_{gl}$,

Due to Lemma (1.5.3.2) and to the triangular identity associated to the left adjoint l , $g_1 \varepsilon^K l_0 * g_1 l_1 \eta^K = g_1 (\varepsilon^K l_0 * l_1 \eta^K) = g_1 1_l = 1_{gl}$, as required.

- ii) On morphisms β in $\mathbf{IntCat}((A_f, C), (B, D))$; $\tilde{\Theta}_{(B,D)}(\beta)$ is a morphism in $(B, D)_F$

- Clearly, $\beta l : gl \longrightarrow g'l$ is a natural transformation.
- The requirement (2.29) translates in this case to $\beta l_0 * g_1 \varepsilon^K l_0 = g'_1 \varepsilon^K l_0 * \beta l_0 r_0 l_0$. This is simply the Godement product equality (1.28), for $\beta \bar{*} \varepsilon^K l_0$. \square

Once the proof that Θ and $\tilde{\Theta}$ are well-defined, has been done, it is natural to state the following

Theorem 3.2.2.2.2. *The object $(C^f \square_C A, C)$ in $\mathbf{IntCat}(\mathfrak{M})$ is a Kleisli object for the monad $F = (f, \mu, \eta^f)$ over (A, C) . That is,*

$$Alg_{F_} \xrightarrow{\cong} \mathbf{IntCat}((C^f \square_C A, C), _).$$

Proof:

- i) $\Theta : Alg_{F_} \longrightarrow \mathbf{IntCat}((C^f \square_C A, C), _)$ is a natural transformation.

The following diagram must commute for any $(h_1, h_0) : (B, D) \longrightarrow (B', D')$

$$\begin{array}{ccc}
Alg_F(B, D) & \xrightarrow{Alg_F(h)} & Alg_F(B', D') \\
\Theta_{(B, D)} \downarrow & & \downarrow \Theta_{(B', D')} \\
\mathbf{IntCat}((A_f, C), (B, D)) & \xrightarrow{\mathbf{IntCat}((A_f, C), h)} & \mathbf{IntCat}((A_f, C), (B', D'))
\end{array}$$

Since this is a functorial diagram, its commutativity has to be proved as much for objects as for morphisms. Let (s, σ) be in $Alg_F(B, D)$, then

$$\begin{aligned}
(\Theta_{(B', D')} \circ Alg_F(h))(s, \sigma) &= (h_0 s_0, m_{B'} \cdot (h_1 \sigma \square_{D'} h_1 s_1) \cdot \iota_{hs}) \\
&= (h_0 s_0, m_{B'} \cdot (h_1 \square_{D'} h_1) \cdot \iota_h \cdot (\sigma \square_{D'} s_1) \cdot \iota_s) \\
&= (h_0 s_0, h_1 \cdot m_B \cdot (\sigma \square_D s_1) \cdot \iota_s) \\
&= h_*(s_0, m_B \cdot (\sigma \square_D s_1) \cdot \iota_s) \\
&= (\mathbf{IntCat}((C^f \square_C A, C), h) \circ \Theta_{(B, D)})(s, \sigma) .
\end{aligned}$$

In the second equality, the factorization lemma in Lemma A.2 was used.

On morphisms, let $\Sigma : (s, \sigma) \longrightarrow (s', \sigma')$ be a morphism in $Alg_F(B, D)$, then

$$\begin{aligned}
(\Theta_{(B', D')} \circ Alg_F(h))(\Sigma) &= h_1 \Sigma \\
&= h_*(\Sigma) \\
&= (\mathbf{IntCat}((C^f \square_C A, C), h) \circ \Theta_{(B, D)})(\Sigma) .
\end{aligned}$$

Next, Θ , as a 2-natural transformation, has to fulfill the requirement (1.24). Note though that if in this requirement $\mathcal{B} = \mathbf{2Cat}$, the equality given by (1.24) simplifies to the equality

$$\alpha_B(F\gamma X) = G\gamma_{\alpha_A X} ,$$

for any object X in the category FA . This simplified equation is verified for Θ and (s, σ) an object in $Alg_F(B, D)$ as follows:

$$\begin{aligned}
\Theta_{(B', D')} (Alg_F(\gamma)(s, \sigma)) &= \Theta_{(B', D')} (\gamma s_0) \\
&= \gamma s_0 \\
&= \mathbf{IntCat}((C^f \square_C A, C), \gamma)(m_B \cdot (\sigma \square_D s_1) \cdot \iota_s, s_0) \\
&= \mathbf{IntCat}((C^f \square_C A, C), \gamma)(\Theta_{(B, D)}(s, \sigma)) .
\end{aligned}$$

Therefore, the naturality of Θ is proved. That Θ is an isomorphism is proved as follows.

ii) $\Theta \circ \tilde{\Theta} = 1_{\mathbf{IntCat}((A_f, C), _)}.$

- On objects, let (g_1, g_0) be an object in $\mathbf{IntCat}((C^f \square_C A, C), (B, D))$, then

$$(\Theta \circ \tilde{\Theta})(g_1, g_0) = \Theta(gl, g_1 \varepsilon^K l_0) = (m_B \cdot (g_1 \varepsilon^K l_0 \square_D g_1 l_1) \cdot \iota_{gl}, g_0 l_0) .$$

Since $l_0 = 1_C$, there only remains to prove that $m_B \cdot (g_1 \varepsilon^K l_0 \square_D g_1 l_1) \cdot \iota_{gl} = g_1$. To do so, let $c \otimes a$ be a generalized object in $C^f \otimes A$, then

$$\begin{aligned} (m_B \cdot (g_1 \varepsilon^K l_0 \square_D g_1 l_1) \cdot \iota_{gl})(c \otimes a) &= (m_B \cdot (g_1 \square_D g_1) \cdot \iota_g \cdot (\varepsilon^K l_0 \square_D l_1) \cdot \iota_l)(c \otimes a) \\ &= g_1 m_f(\varepsilon^K l_0(c) \otimes l_1(a)) \\ &= g_1 m_f(c_{(1)} \otimes f_1 u_A(c_{(2)}) \otimes a_{[-1](1)} \otimes \eta^f(a_{[-1](2)}) a_{[0]}) \\ &= g_1 (c_{(1)} \otimes \mu(c_{(2)}) f_1 f_1 u_A(c_{(3)}) \eta^f(a_{[-1]}) a_{[0]}) \\ &= g_1 (c_{(1)} \otimes \mu(c_{(2)}) f_1 f_1 u_A(c_{(3)}) \eta^f f_0(c_{(4)}) a) \\ &= g_1 (c_{(1)} \otimes u_A f_0(c_{(2)}) a) \\ &= g_1 (c_{(1)} \otimes u_A(a_{[-1]}) a_{[0]}) \\ &= g_1(c \otimes a) . \end{aligned}$$

In the first equality, the factorization lemma A.2 was applied. In the second equality, the compatibility with multiplications of g_1 was used. In the fourth equality, the right C -colinearity of u_A was applied. In the fifth equality, the fact that the generalized element $c_{(1)} \otimes c_{(2)} \otimes a$ is in $C \square_C C^f \square_C A$ was used. In the sixth equality, (3.22) was used.

- On morphisms, let $\beta : (g_1, g_0) \longrightarrow (g'_1, g'_0)$, then

$$\Theta \circ \tilde{\Theta}(\beta) = \Theta(\beta l_0) = \beta l_0 = \beta .$$

iii) $\tilde{\Theta} \circ \Theta = 1_{\mathbf{Alg}_F _}.$

- On objects, let (s, σ) be an object in $(B, D)_F$, then

$$\begin{aligned} \tilde{\Theta} \circ \Theta(s_1, s_0, \sigma) &= \tilde{\Theta}(m_B \cdot (\sigma \square_C s_1) \cdot \iota_s, s_0) \\ &= ((m_B \cdot (\sigma \square_C s_1) \cdot \iota_s) \cdot l_1, s_0 l_0, (m_B \cdot (\sigma \square_C s_1) \cdot \iota_s) \cdot \varepsilon^K l_0) . \end{aligned}$$

Therefore, for the first component, if a is a generalized element in A ,

$$\begin{aligned} (m_B \cdot (\sigma \square_C s_1) \cdot \iota_s) \cdot l_1(a) &= \sigma(a_{[-1](1)}) s_1(\eta^f(a_{[-1](2)}) a_{[0]}) \\ &= (\sigma * s_1 \eta^f)(a_{[-1]}) s_1(a_{[0]}) \\ &= s_1 u_A(a_{[-1]}) s_1(a_{[0]}) \\ &= s_1(u_A(a_{[-1]}) a_{[0]}) \\ &= s_1(a) . \end{aligned}$$

In the third equality, the requirement $\sigma * s_1 \eta^f = 1_s$ was used and in the fifth one, the unitality of u_A .

On the other hand, for the third component, if c is a generalized element of C ,

$$\begin{aligned} ((m_B \cdot (\sigma \square_C s_1) \cdot \iota_s) \cdot \varepsilon^K l_0)(c) &= \sigma(c_{(1)}) s_1 f_1 u_A(c_2) \\ &= \sigma(c_{(1)}) u_A(s_0 f_0(c_{(2)})) \\ &\stackrel{3.8b}{=} \sigma(c)_{[0]} u_A(\sigma(c)_{[1]}) \\ &= \sigma(c) . \end{aligned}$$

- On morphisms, let $\bar{\Sigma} : (s, \sigma) \longrightarrow (s', \sigma')$, then

$$\tilde{\Theta} \circ \Theta(\Sigma) = \tilde{\Theta}(\Sigma) = \Sigma l_0 = \Sigma .$$

□

3.2.3 CoKleisli Objects in $\mathbf{IntCat}(\mathfrak{M})$

Let $(g, \delta, \varepsilon^g)$ be a comonad in $\mathbf{IntCat}(\mathfrak{M})$ over the internal category (A, C) . The coKleisli internal category is defined as follows:

- The object of morphisms and the object of objects are defined as $(A \square_C^g C, C)$ respectively, in short notation (A^g, C) .

- The multiplication $m_g : A \square_C^g C \square_C A \square_C^g C \cong A \square_C^g A \square_C^g C \longrightarrow A \square_C^g C$ is defined as

$$m_g = (m_A^2 \square_C^g C) \cdot (A \square_C g_1 \square_C \delta \square_C^g C) \cdot (A \square_C \iota_g^2) \cdot (A \square_C^g A \square_C^g \tilde{\Delta}_C) , \quad (3.23)$$

which, over a generalized element $a \otimes a'_{[-1]} \otimes a'_{[0]} \otimes c$ in $A \square_C^g C \square_C A \square_C^g C$, acts as,

$$a \otimes a'_{[-1]} \otimes a'_{[0]} \otimes c \longmapsto a g_1(a') \delta(c_{(1)}) \otimes c_{(2)} .$$

- The unit $u_g : C \longrightarrow A \square_C^g C$ is defined as

$$u_g = (\varepsilon^g \square_C^g C) \cdot \iota_g \cdot \tilde{\Delta}_C ,$$

which, over generalized elements c in C , acts as

$$c \longmapsto \varepsilon^g(c_{(1)}) \otimes c_{(2)} .$$

The next propositions and theorems are given without proof since their proofs are essentially the same as the respective ones for the Kleisli object, that is to say, *mutatis mutandis*. Nevertheless, the reference of the mate proof is given for each of the following propositions.

Proposition 3.2.3.1. $((A \square_C^g C, C), m_g, u_g)$ is an internal category.

Proof: cf. 3.2.2.1.1 □

Let us propose here in the same way as before the g -adjunction of the internal category (A, C) over the coKleisli object (A^g, C) , that is to say,

$$(A \square_C^g C, C) \begin{array}{c} \xleftarrow{r} \\ \xrightarrow{l} \end{array} (A, C) \quad .$$

The internal functor $l : (A^g, C) \longrightarrow (A, C)$ consists of the following pair of morphisms:

$$\begin{aligned} l_0 &= g_0 , \\ l_1 &= m_A \cdot (g_1 \square_C \delta) \cdot \iota_g , \end{aligned}$$

where the last morphism acts over generalized elements, $a \otimes c$ in $A \square_C^g C$, as

$$a \otimes c \longmapsto g_1(a)\delta(c) \quad .$$

The internal functor $r : (A, C) \longrightarrow (A^g, C)$ is given as the following pair of morphisms,

$$\begin{aligned} r_0 &= 1_C , \\ r_1 &= (m_A \square_C^g C) \cdot (A \square_C \varepsilon^g \square_C^g C) \cdot (A \square_C \iota_g) \cdot (A \square_C \tilde{\Delta}_C) \cdot \tilde{\rho}_A^C . \end{aligned}$$

Proposition 3.2.3.2. The pairs l and r just defined are functors between the internal categories (A^g, C) and (A, C) .

Proof: cf. 3.2.2.1.2 □

If the previous pair of functors has to be an adjunction then a unit and counit must be provided. The unit $\eta^{coK} : 1_{(A^g, C)} \longrightarrow rl$,

$$\eta^{coK} : C \longrightarrow A \square_C^g C$$

is the following morphism

$$\eta^{coK} = (g_1 \square_{C^g} C) \cdot \iota_g \cdot (u_A \square_C C) \cdot \tilde{\Delta}_C ,$$

which over generalized elements c in C , acts as

$$c \longmapsto g_1 u_A(c_{(1)}) \otimes c_{(2)} .$$

For the counit of the adjunction, it is clear that $lr = g$, therefore the counit

$$\varepsilon^{coK} : g = lr \longrightarrow 1_{(A,C)} ,$$

is taken as

$$\varepsilon^{coK} = \varepsilon^g .$$

With the previous definition of unit and counit, the following proposition can be stated

Proposition 3.2.3.3. *The following is an adjunction*

$$(A \square_{C^g} C, C) \underset{l}{\overset{r}{\rightleftarrows}} (A, C) ,$$

and the comonad induced over (A, C) is the one which the construction of the coKleisli object started with, that is to say $(g, \delta, \varepsilon^g)$.

Proof: cf. 3.2.2.1.4. □

Just as in Section 3.2.2.2, $(A \square_{C^g} C, C)$ being a coKleisli object means, according to [24], that it is a representative object for the coalgebraic functor $Coalg_G$. According to the isomorphism of categories in (2.26), another 2-cell in the 2-category $\mathbf{2}\mathbf{Cat}$ can be constructed

$$\begin{array}{ccc} & \text{Coalg}_G _ & \\ & \curvearrowright & \\ \mathbf{IntCat}(\mathfrak{M}) & \downarrow \cong \quad \Theta' & \mathbf{2Cat} , \\ & \curvearrowleft & \\ & \mathbf{IntCat}((A_g, C), _) & \end{array}$$

where $\mathcal{A} = \mathbf{IntCat}(\mathfrak{M})$ and $A_{coK} = (A \square_{C^g} C, C)$. Let (B, D) be an internal category in $\mathbf{IntCat}(\mathfrak{M})$, then

$$\Theta'_{(B,D)} : \text{Coalg}_G(B, D) \longrightarrow \mathbf{IntCat}((A \square_{C^g} C, C), (B, D)) ,$$

is a 1-cell in $\mathbf{2}\mathbf{Cat}$, that is to say, a functor which is defined as follows.

i) On objects (s, σ) in $\mathit{Coalg}_G(B, D)$, Θ' is defined as,

$$\begin{aligned} (\Theta'_{(B,D)}(s, \sigma))_0 &= s_0 , \\ (\Theta'_{(B,D)}(s, \sigma))_1 &= m_B \cdot (s_1 \square_D \sigma) \cdot \iota_s . \end{aligned}$$

ii) On morphisms $\bar{\Sigma} : (s, \sigma) \longrightarrow (t, \tau)$, Θ' is defined as

$$\Theta'_{(B,D)}(\bar{\Sigma}) = \bar{\Sigma} .$$

The proposal for the inverse natural transformation $\tilde{\Theta}'$ goes as follows.

i') On objects $k = (k_1, k_0)$ in $\mathbf{IntCat}((A_g, C), (B, D))$, $\tilde{\Theta}'$ is defined as,

$$\begin{aligned} (\tilde{\Theta}'_{(B,D)}(k_1, k_0)_s)_0 &= k_0 r_0 , \\ (\tilde{\Theta}'_{(B,D)}(k_1, k_0)_s)_1 &= k_1 r_1 , \\ \tilde{\Theta}'_{(B,D)}(k_1, k_0)_\sigma &= k_1 \eta^{coK} r_0 . \end{aligned}$$

ii') On morphisms $\gamma : (k_1, k_0) \longrightarrow (k'_1, k'_0)$, $\tilde{\Theta}'$ is defined as

$$\tilde{\Theta}'_{(B,D)}(\gamma) = \gamma r_0 .$$

Without further ado, the following theorem can be stated,

Theorem 3.2.3.4. *The morphism Θ' is a 2-natural isomorphism and the object $(A \square_{C^g} C, C)$ is a coKleisli object for the comonad $G = (g, \delta, \varepsilon^g)$ over (A, C) , that is*

$$\mathit{Coalg}_{G_-} \xrightarrow{\cong} \mathbf{IntCat}((A \square_{C^g} C, C), _)$$

Proof: 3.2.2.2.1 and 3.2.2.2.2 □

3.3 Internal Kleisli Objects and the Formal Theory of Monads

In order to obtain the Kleisli and coKleisli objects for a monad in the 2-category $\mathbf{IntCat}(\mathfrak{M})$ and Kleisli objects for a monad in the 2-category $\mathbf{IntCoCat}(\mathfrak{M})$ another tool is developed, namely by using the properties of the bicategory $\mathbf{KL}(\mathcal{A})$, for a specific bicategory \mathcal{A} , see [10] and [20]. Therefore, this section begins by introducing the bicategory $\mathbf{KL}(\mathbf{Bicomod}(\mathfrak{M}))$, afterwards several locally full and faithful bifunctors Φ , $\hat{\Phi}$ and Ψ into $\mathbf{KL}(\mathbf{Bicomod}(\mathfrak{M}))$ are defined which will enable us to find the Kleisli and coKleisli objects mentioned above.

3.3.1 The Bicategory of $\mathbf{KL}(\mathbf{Bicomod}(\mathfrak{M}))$

The 2-category $\mathbf{KL}(\mathcal{A})$, for a 2-category \mathcal{A} , and the bicategory $\mathbf{Bicomod}(\mathfrak{M})$ have been already defined, out of these constructions let us outline the bicategory $\mathbf{KL}(\mathbf{Bicomod}(\mathfrak{M}))$, in order to have the references and concepts at hand for the theory to follow.

The 0-cells for this bicategory are monads in $\mathbf{Bicomod}(\mathfrak{M})$, that is

$$C \xrightarrow{A} C \quad , \quad C \begin{array}{c} \xrightarrow{A \square_C A} \\ \downarrow m_A \\ \xrightarrow{A} \end{array} C \quad , \quad C \begin{array}{c} \xrightarrow{C} \\ \downarrow u_A \\ \xrightarrow{A} \end{array} C \quad .$$

Remark 3.3.1.1. $\mathbf{KL}_0(\mathbf{Bicomod}(\mathfrak{M})) = \mathbf{Mnd}_0(\mathbf{Bicomod}(\mathfrak{M})) = \mathbf{IntCat}_0(\mathfrak{M}) = \mathbf{IntCoCat}_0(\mathfrak{M})$.

The 1-cells for this bicategory are

$$(C, A) \xrightarrow{(M, \phi)} (D, B) \quad ,$$

such that

$$C \xrightarrow{M} D \quad , \quad C \begin{array}{c} \xrightarrow{A \square_C M} \\ \downarrow \phi \\ \xrightarrow{M \square_D B} \end{array} D \quad ,$$

are cells in $\mathbf{Bicomod}(\mathfrak{M})$ such that the following diagrams commute

$$\begin{array}{ccc} A \square_C A \square_C M & \xrightarrow{A \square_C \phi} & A \square_C M \square_D B & \xrightarrow{\phi \square_D B} & M \square_D B \square_D B \\ \downarrow m_A \square_C M & & \downarrow M \square_D m_B & & \\ A \square_C M & \xrightarrow{\phi} & M \square_D B & & \end{array} \quad , \quad \begin{array}{ccc} & M & \\ u_A \square_C M \swarrow & & \searrow M \square_D u_B \\ A \square_C M & \xrightarrow{\phi} & M \square_D B \end{array} .$$

The 2-cells for this category are

$$(C, A) \begin{array}{c} \xrightarrow{(M, \phi)} \\ \downarrow \bar{\Lambda} \\ \xrightarrow{(M', \phi')} \end{array} (D, B) \quad ,$$

such that

$$\begin{array}{ccc}
& M & \\
C & \xrightarrow{\quad} & D \\
& \downarrow \Lambda & \\
& M' \square_D B &
\end{array} ,$$

is a 2-cell in $\mathbf{Bicomod}(\mathfrak{M})$, and the following diagram

$$\begin{array}{ccc}
A \square_C M & \xrightarrow{\phi} & M \square_C B \xrightarrow{\Lambda \square_D B} M' \square_D B \square_D B \\
\downarrow A \square_C \Lambda & & \downarrow M' \square_D m_B \\
A \square_C M' \square_D B & & \\
\downarrow \phi' \square_D B & & \\
M' \square_D B \square_D B & \xrightarrow{M' \square_D m_B} & M' \square_D B
\end{array} , \tag{3.24}$$

commutes.

For the underlying category of $\mathbf{KL}(\mathbf{Bicomod}(\mathfrak{M}))$, the composition over the following 1-cell diagram

$$\begin{array}{ccccc}
& (M, \phi) & & (N, \gamma) & \\
(C, A) & \xrightarrow{\quad} & (C', A') & \xrightarrow{\quad} & (C'', A'')
\end{array} ,$$

is defined as

$$(M, \phi) \cdot (N, \gamma) = (M \square_{C'} N, (M \square_{C'} \gamma) \cdot (\phi \square_{C'} N)) .$$

The vertical structure of $\mathbf{KL}(\mathbf{Bicomod}(\mathfrak{M}))$ is defined over the following 2-cell diagram

$$\begin{array}{ccc}
& (M, \phi) & \\
& \downarrow \bar{\Lambda} & \\
(C, A) & \xrightarrow{(M', \phi')} & (D, B) \\
& \downarrow \bar{\Lambda}' & \\
& (M'', \phi'') &
\end{array}$$

as

$$\bar{\Lambda}' \circ \bar{\Lambda} = \overline{(M'' \square_D m_B) \cdot (\Lambda' \square_D B) \cdot \Lambda} .$$

The horizontal structure of $\mathbf{KL}(\mathbf{Bicomod}(\mathfrak{M}))$ is defined through the following 2-cell diagram

$$\begin{array}{ccccc} & (M, \phi) & & (N, \gamma) & \\ & \curvearrowright & & \curvearrowright & \\ (C, A) & \downarrow \bar{\Lambda} & (C', A') & \downarrow \bar{\Gamma} & (C'', A'') \text{ ,} \\ & \curvearrowleft & & \curvearrowleft & \\ & (M', \phi') & & (N', \gamma') & \end{array}$$

as

$$\bar{\Lambda} * \bar{\Gamma} = \overline{(M' \square_{C'} N' \square_{C''} m_{A''}) \cdot (M' \square_{C'} \Gamma \square_{C''} A'') \cdot (M' \square_{C'} \gamma) \cdot (\Lambda \square_{C'} N)} .$$

3.3.2 Bifunctors

This subsection is devoted to the construction of locally full embedded bifunctors to the bicategory $\mathbf{KL}(\mathcal{B})$, where \mathcal{B} is a bicategory, see [10]. The reason for such constructions is explained as follows. According to [20], the bicategory $\mathbf{KL}(\mathcal{B})$ is complete with respect to Kleisli objects, that is to say, for any monad in $\mathbf{KL}(\mathcal{B})$, this bicategory has the corresponding Kleisli object. Therefore, let us give a 2-category $\mathbf{M}(\mathcal{B}')$, for a bicategory \mathcal{B}' , whose 0-cells are monads in \mathcal{B}' and the remain structure is known but it is not necessary to be detailed. Then, if there exists a locally full embedding bifunctor, which is the identity on 0-cells, $F : \mathbf{M}(\mathcal{B}') \rightarrow \mathbf{KL}(\mathcal{B})$, any monad in $\mathbf{M}(\mathcal{B}')$ will render a monad in $\mathbf{KL}(\mathcal{B})$, which has a Kleisli object. In particular, this Kleisli object is a monad in \mathcal{B} hence, using the identification on 0-cells of F , this object can be seen as a monad in \mathcal{B}' , *i.e.* a 0-cell in $\mathbf{M}(\mathcal{B}')$. In summary, the 2-category $\mathbf{M}(\mathcal{B}')$ will have Kleisli objects through the locally full embedding F .

The first bifunctor to construct with the previous characteristics is $\Phi : \mathbf{IntCat}(\mathfrak{M}) \rightarrow \mathbf{KL}(\mathbf{Bicomod}(\mathfrak{M}))$. Over 0-cells (A, C) in $\mathbf{IntCat}(\mathfrak{M})$ it is defined as

$$\Phi(A, C, m_A, u_A) = (C, A, m_A, u_A) .$$

That is to say, the identity on 0-cells. Over 1-cells,

$$\begin{array}{ccc} & (f_1, f_0) & \\ & \curvearrowright & \\ (A, C) & & (B, D) \text{ ,} \end{array}$$

as

$$\Phi(f_1, f_0) = (C^f, \phi_f) = (C^f, (C^f \square_C f_1) \cdot \iota_f^f \cdot \tilde{\rho}_{A^f}^C) ,$$

where $\phi_f : A \square_C C^f \cong A^f \rightarrow C^f \square_C B$ is a morphism in ${}^C\mathcal{M}^D$. Over a 2-cell,

$$\begin{array}{ccc}
& (f_1, f_0) & \\
& \curvearrowright & \\
(A, C) & \downarrow \alpha & (B, D) , \\
& \curvearrowleft & \\
& (g_1, g_0) &
\end{array}$$

as

$$\begin{array}{ccc}
& (C^f, \phi'_f) & \\
& \curvearrowright & \\
(C, A) & \downarrow \overline{\Phi(\alpha)} & (D, B) , \\
& \curvearrowleft & \\
& (C^g, \phi'_g) &
\end{array}$$

where $\overline{\Phi(\alpha)} = (C^g \square_D \alpha) \cdot \iota_g^f \cdot \tilde{\Delta}_C^f$ and $\Phi(\alpha) : C^f \longrightarrow C^g \square_D B$ is a morphism in $\mathcal{C}\mathcal{M}^D$. This definition renders a bifunctor.

Proposition 3.3.2.1. *The bifunctor $\Phi : \mathbf{IntCat}(\mathfrak{M}) \longrightarrow \mathbf{KL}(\mathbf{Bicomod}(\mathfrak{M}))$ is a locally full embedding.*

Proof:

First we show that the bifunctor is locally injective on objects. Let (A, C) and (B, D) be 0-cells in $\mathbf{IntCat}(\mathfrak{M})$. Take objects $f, g : (A, C) \longrightarrow (B, D)$ such that

$$\Phi(f) = \Phi(g) . \quad (3.25)$$

Then clearly $f_0 = g_0$ from $C^f = C^g$. Let a be a generalized element in A , then because of (3.25), $a_{[-1]} \otimes f_1(a_{[0]}) = a_{[-1]} \otimes g_1(a_{[0]})$. If $m_B(u_B f_0(_) \otimes _)$ is applied to the left hand side of this equality, then

$$u_A f_0(a_{[-1]}) f_1(a_{[0]}) \stackrel{3.7c}{=} u_a(f_1(a)_{[-1]}) f_1(a)_{[0]} = f_1(a) .$$

On the other hand, if $m_B(u_B g_0(_) \otimes _)$ is applied to the right hand side of the aforementioned equality, which is the same as $m_B(u_B f_0(_) \otimes _)$ since $f_0 = g_0$, we obtained the morphism g_1 , hence we conclude that $f_1 = g_1$.

That Φ is locally faithful, is proved as follows. Let $\alpha : f \longrightarrow g$ and $\beta : h \longrightarrow k$ be 2-cells in $\mathbf{IntCat}(\mathfrak{M})((A, C), (B, D))$, such that $\overline{\Phi(\alpha)} = \overline{\Phi(\beta)}$, then

$$(C^g \square_D \alpha) \cdot \iota_g \cdot \tilde{\Delta}_C^f = (C^k \square_D \beta) \cdot \iota_k \cdot \tilde{\Delta}_C^h .$$

In the same way as before, we apply $m_B(u_B g_0(_) \otimes _)$ to the left hand side and $m_B(u_B k_0(_) \otimes _)$ to the right hand side to obtain $\alpha = \beta$.

In order to prove the local fullness, consider the following 2-cell $\bar{\Lambda} : (C^f, \phi_f) \longrightarrow (C^g, \phi_g)$ in $\mathbf{KL}(\mathbf{Bicomod}(\mathfrak{M}))((C, A), (D, B))$, then define the proposed internal natural transformation as

$$\alpha = m_B \cdot (u_B g_0 \square_D B) \cdot \Lambda .$$

Clearly $\alpha : {}^g C^f \longrightarrow B$ is a morphism in ${}^D \mathcal{M}^D$. The naturality of this morphism $\alpha(a_{[-1]})f_1(a_{[0]}) = g_1(a_{[0]})\alpha(a_{[1]})$, is proved as follows. If c is a generalized element in C^f then write $\Lambda(c) = c_\lambda \otimes c_{\bar{\lambda}}$, where $c_\lambda \otimes c_{\bar{\lambda}}$ is a generalized element in $C^g \square_D B$. Let a in A^f be a generalized element, then

$$\begin{aligned} \alpha(a_{[-1]})f_1(a_{[0]}) &= u_B g_0(a_{[-1]\lambda})a_{[-1]\bar{\lambda}}f_1(a_{[0]}) \\ &= u_B g_0\left((a_{[0]}\varepsilon(a_{[1]\lambda}))_{[-1]}\right)g_1\left((a_{[0]}\varepsilon(a_{[1]\lambda}))_{[0]}\right)a_{[1]\bar{\lambda}} \\ &= g_1\left((a_{[0]}\varepsilon(a_{[1]\lambda}))_{[0]}\right)u_B g_0\left((a_{[0]}\varepsilon(a_{[1]\lambda}))_{[1]}\right)a_{[1]\bar{\lambda}} \\ &= g_1\left((a_{[0]}u_A(a_{[1]\lambda}))_{[0]}\right)u_B g_0\left((a_{[0]}u_A(a_{[1]\lambda}))_{[1]}\right)a_{[1]\bar{\lambda}} \\ &= g_1\left(a_{[0]}(u_A(a_{[1]\lambda}))_{[0]}\right)u_B g_0\left((u_A(a_{[1]\lambda}))_{[1]}\right)a_{[1]\bar{\lambda}} \\ &= g_1(a_{[0]})g_1\left((u_A(a_{[1]\lambda}))_{[0]}u_A((u_A(a_{[1]\lambda}))_{[1]})\right)a_{[1]\bar{\lambda}} \\ &= g_1(a_{[0]})g_1 u_A(a_{[1]\lambda})a_{[1]\bar{\lambda}} \\ &= g_1(a_{[0]})u_B g_0(a_{[1]\lambda})a_{[1]\bar{\lambda}} \\ &= g_1(a_{[0]})\alpha(a_{[1]}) . \end{aligned}$$

In the second equality the fact that Λ is a 2-cell in $\mathbf{KL}(\mathbf{Bicomod})$, (3.24) , was used. The third equality, follows by the next equality of morphisms

$$\begin{aligned} m_B \cdot (u_B \square_D B) \cdot (g_0 \square_D g_1) \cdot \iota_g \cdot \tilde{\rho}_A^C &= m_B \cdot (u_B \square_D B) \cdot {}^D \tilde{\rho}_B \cdot g_1 \\ &= g_1 \\ &= m_B \cdot (B \square_D u_B) \cdot \tilde{\rho}_B^D \cdot g_1 \\ &= m_B \cdot (B \square_D u_B) \cdot (g_1 \square_D g_0) \cdot \iota_g \cdot \tilde{\rho}_A^C . \end{aligned}$$

In the fourth equality the equation $a\varepsilon(c) = au_A(c)$ coming from the unitality of u_A was used. In the fifth equality, the right colinearity of m_A was used. Finally, in the sixth equality the multiplicativity of g_1 was used.

That $\Phi(\alpha) = (C^g \square_D (m_B \cdot (u_B g_0 \square_D B) \cdot \Lambda)) \cdot \iota_g \cdot \tilde{\Delta}_C^f = \Lambda$, follows by the next calculation, where c is a generalized element in C^f ,

$$\begin{aligned} \Phi(\alpha)(c) &= c_{(1)} \otimes u_B g_0(c_{(2)\lambda}) c_{(2)\tilde{\lambda}} \\ &= c_{\lambda(1)} \otimes u_B g_0(c_{\lambda(2)}) c_{\tilde{\lambda}} \\ &= c_{\lambda} \otimes u_B(c_{\tilde{\lambda}[-1]}) c_{\tilde{\lambda}[0]} \\ &= c_{\lambda} \otimes c_{\tilde{\lambda}} \\ &= \Lambda(c) . \end{aligned}$$

In the second equality, the left C -colinearity of Λ was applied. The third equality follows from the fact that $c_{\lambda} \otimes c_{\tilde{\lambda}}$ is a generalized element in $C^g \square_D B$. The fourth equality uses the unitality of u_B . □

There is another functor of bicategories for the comonads counterpart, with the required characteristics, $\widehat{\Phi} : \mathbf{IntCat}^{co}(\mathfrak{M}) \longrightarrow \mathbf{KL}(\mathbf{Bicomod}^{op}(\mathfrak{M}))$ and this is described as follows. Over 0-cells (A, C) , $\widehat{\Phi}$ is defined as

$$\widehat{\Phi}(A, C, m_A, u_A) = (C, A, m_A, u_A) .$$

Again, it is defined as the identity on 0-cells. Over 1-cells,

$$(A, C) \xrightarrow{(f_1, f_0)} (B, D) ,$$

it is defined as

$$\widehat{\Phi}(f_1, f_0) = ({}^f C, \phi'_f) = ({}^f C, (f_1 \square_D {}^f C) \cdot {}^f \iota_f \cdot {}^f \tilde{\rho}_A^C) ,$$

where $\phi'_f : {}^f C \square_C A \cong {}^f A \longrightarrow B \square_D {}^f C$ is a morphism in ${}^D \mathcal{M}^C$. Over a 2-cell,

$$\begin{array}{ccc} & (f_1, f_0) & \\ & \curvearrowright & \\ (A, C) & \downarrow \alpha^{co} & (B, D) \\ & \curvearrowleft & \\ & (g_1, g_0) & \end{array} ,$$

as

$$\begin{array}{ccc}
& \xrightarrow{(fC, \phi_f)^{op}} & \\
(C, A) & \downarrow \bar{\Gamma}_\alpha & (D, B) , \\
& \xrightarrow{(gC, \phi_g)^{op}} &
\end{array}$$

where $\bar{\Gamma}_\alpha = (\alpha \square_D gC) \cdot f_{\iota_g} \cdot f_{\tilde{\Delta}_C}$ and $\Gamma_\alpha : fC \rightarrow B \square_D gC$ is a morphism in ${}^D\mathcal{M}^C$. $\hat{\Phi}$ defined in this way, is a functor of bicategories too.

Proposition 3.3.2.2. *The bifunctor $\hat{\Phi} : \mathbf{IntCat}^{co}(\mathfrak{M}) \rightarrow \mathbf{KL}(\mathbf{Bicomod}^{op}(\mathfrak{M}))$ is a locally full embedding.*

Proof:

In view of the left-right symmetry between definitions of Φ and $\hat{\Phi}$, this proof is analogous to that of Φ . \square

The final bifunctor to describe, Ψ , has as its domain the 2-category $\mathbf{IntCoCat}(\mathfrak{M})$, cf. Subsection 1.5.4. Therefore, this bifunctor will provide us with Kleisli objects in this 2-category. The bifunctor, $\Psi : \mathbf{IntCoCat}(\mathfrak{M}) \rightarrow \mathbf{KL}(\mathbf{Bicomod}(\mathfrak{M}))$ is defined as follows. Over 0-cells in (A, C) , it is described as

$$\Psi(A, C, m_A, u_A) = (C, A, m_A, u_A) .$$

Yet again, it is the identity on 0-cells. Over 1-cells,

$$\begin{array}{ccc}
& \xrightarrow{(f_1, f_0)} & \\
(A, C) & & (B, D) ,
\end{array}$$

it is defined as

$$\Psi(f_1, f_0) = ({}^fD, \gamma_f) = ({}^fD, {}^fD\tilde{\rho}_B \cdot f_1) ,$$

where $\gamma_f : A \square_C {}^fD \rightarrow {}^fD \square_D B$ is a morphism in ${}^C\mathcal{M}^D$. Over a 2-cell,

$$\begin{array}{ccc}
& \xrightarrow{(f_1, f_0)} & \\
(A, C) & \downarrow \alpha & (B, D) , \\
& \xrightarrow{(g_1, g_0)} &
\end{array}$$

as

$$\begin{array}{ccc}
 & ({}^fD, \gamma_f) & \\
 & \curvearrowright & \\
 (C, A) & \downarrow \overline{\Psi(\alpha)} & (D, B) , \\
 & \curvearrowleft & \\
 & ({}^gD, \gamma_g) &
 \end{array}$$

where $\overline{\Psi(\alpha)} = {}^gD\tilde{\rho}_B \cdot \alpha$ and $\Psi(\alpha) : {}^fD \longrightarrow {}^gD \square_D B$ is a morphism in ${}^C\mathcal{M}^D$. As expected, Ψ is also a functor of bicategories.

Proposition 3.3.2.3. *The bifunctor $\Psi : \mathbf{IntCoCat}(\mathfrak{M}) \longrightarrow \mathbf{KL}(\mathbf{Bicomod}(\mathfrak{M}))$ is a locally full embedding.*

Proof:

That the bifunctor is injective on objects and faithful is proved in a similar way as in the proof of the Proposition 3.3.2.1. That the bifunctor is full can be proved as follows.

Let $\overline{\Gamma} : ({}^fD, \gamma_f) \longrightarrow ({}^gD, \gamma_g) : (C, A) \longrightarrow (D, B)$ be a 2-cell in $\mathbf{KL}(\mathbf{Bicomod}(\mathfrak{M}))$, then $\alpha : f \longrightarrow g : (A, C) \longrightarrow (B, D)$ such that $\Psi(\alpha) = \overline{\Gamma}$ is defined as

$$\alpha = m_B \cdot (u_B \square_D B) \cdot \Gamma .$$

This morphism in \mathfrak{M} is easily seen as a morphism in ${}^C\mathcal{M}^D$. Its naturality is proved as follows. If d is generalized element of fD , then write $\Gamma(d) = d_\gamma \otimes d_{\tilde{\gamma}}$, where $d_\gamma \otimes d_{\tilde{\gamma}}$ is a generalized element in ${}^gD \square_D B$. Let $a \otimes d$ be a generalized element in $A \square_C {}^fD$, then

$$\begin{aligned}
 g_1(a \otimes \alpha(d)_{[-1]})\alpha(d)_{[0]} &= g_1(a \otimes (u_B(d_\gamma)d_{\tilde{\gamma}})_{[-1]})(u_B(d_\gamma)d_{\tilde{\gamma}})_{[0]} \\
 &= g_1(a \otimes (u_B(d_\gamma))_{[-1]})(u_B(d_\gamma))_{[0]}d_{\tilde{\gamma}} \\
 &= g_1(a \otimes d_{\gamma(1)})u_B(d_{\gamma(2)})d_{\tilde{\gamma}} \\
 &= g_1(a \otimes d_\gamma)u_B(d_{\tilde{\gamma}[-1]})d_{\tilde{\gamma}[0]} \\
 &= g_1(a \otimes d_\gamma)d_{\tilde{\gamma}} \\
 &= u_B((g_1(a \otimes d_\gamma)d_{\tilde{\gamma}})_{[-1]})(g_1(a \otimes d_\gamma)d_{\tilde{\gamma}})_{[0]} \\
 &= u_B((g_1(a \otimes d_\gamma))_{[-1]})(g_1(a \otimes d_\gamma))_{[0]}d_{\tilde{\gamma}} \\
 &= u_B((f_1(a \otimes d))_{[-1]\gamma})(f_1(a \otimes d))_{[-1]\tilde{\gamma}}(f_1(a \otimes d))_{[0]} \\
 &= \alpha((f_1(a \otimes d))_{[-1]}) \otimes (f_1(a \otimes d))_{[0]} .
 \end{aligned}$$

In the second and in the seventh equalities the left colinearity of m_B was applied. In the third one, the left colinearity of u_B was used instead. In the fourth one, the fact that $d_\gamma \otimes d_{\tilde{\gamma}}$ is a generalized element in ${}^gD \square_D B$, *i.e.* $d_{\gamma(1)} \otimes d_{\gamma(2)} \otimes d_{\tilde{\gamma}} = d_\gamma \otimes d_{\tilde{\gamma}[-1]} \otimes d_{\tilde{\gamma}[0]}$, was used. In the sixth equality, the unitality of u_B was used. The eighth equality follows by the fact that $\bar{\Gamma}$ is a 2-cell in $\mathbf{KL}(\mathbf{Bicomod}(\mathfrak{M}))$, *i.e.* it fulfills the commutativity of the diagram in (3.24). This requirement is translated, over the generalized element $a \otimes d$ in $A \square_C {}^fD$, to

$$(f_1(a \otimes d))_{[-1]\gamma} \otimes (f_1(a \otimes d))_{[-1]\tilde{\gamma}} (f_1(a \otimes d))_{[0]} = (g_1(a \otimes d_\gamma))_{[-1]} \otimes (g_1(a \otimes d_\gamma))_{[0]} d_{\tilde{\gamma}} .$$

This completes the proof of the proposition. \square

3.3.2.1 Reinterpretation of the Embedding Bifactoriality

The referee assigned to [10] pointed out another interpretation of the embedding of the bifunctors Φ , $\widehat{\Phi}$ and Ψ . In order to write about this other interpretation some background work has to be done before going into detail.

Consider a 2-category \mathcal{A} , a bicategory \mathcal{B} and assume that there is a bifunctor $F : \mathcal{A} \longrightarrow \mathcal{B}$ with the property of being locally fully faithful and identity on objects. Then there exists a 2-category denoted by $\mathbf{KL}_F(\mathcal{B})$ which can also be embedded into $\mathbf{KL}(\mathcal{B})$. Its description goes as follows. The 0-cells are the same as those of $\mathbf{KL}(\mathcal{B})$. The 1-cells in $\mathbf{KL}_F(\mathcal{B})$ are pairs (Fr, φ) in \mathcal{B} , where r is a 1-cell in \mathcal{A} , this pair renders a typical 1-cell in $\mathbf{KL}(\mathcal{B})$. The 2-cells in $\mathbf{KL}_F(\mathcal{B})$ are defined as $\eta^h \Lambda : (Fr, \varphi) \longrightarrow (Fs, \psi) : (A, f) \longrightarrow (A', h)$, where $\Lambda : Fr \longrightarrow Fs : A \longrightarrow A'$ is 2-cell in \mathcal{B} . The previous construction provides a locally full and faithful bifunctor $\mathbf{KL}_F(\mathcal{B}) \longrightarrow \mathbf{KL}(\mathcal{B})$ and because of the discussion at the beginning of this section, $\mathbf{KL}_F(\mathcal{B})$ has also Kleisli objects.

Next, apply this construction to $\mathcal{A} = \mathbf{Comon}(\mathfrak{M})$ and $\mathcal{B} = \mathbf{Bicomod}(\mathfrak{M})$. Obviously, $\mathbf{Comon}(\mathfrak{M})$ do not have a 2-category structure but it can have one according to the bifunctor F in order to make it locally full and faithful. We have three options

†) $F : \mathbf{Comon}(\mathfrak{M}) \longrightarrow \mathbf{Bicomod}(\mathfrak{M})$, is defined by the identity on the 0-cells and for 1-cells $f : C \longrightarrow D$ as the 1-cell C^f in $\mathbf{Bicomod}(\mathfrak{M})$. The 2-cells in $\mathbf{Comon}(\mathfrak{M})$ are defined, in order to make F locally full and faithful, as $\alpha : C^f \longrightarrow C^g$. This definition gives $\mathbf{KL}_F(\mathbf{Bicomod}(\mathfrak{M}))$ as the image under Φ of $\mathbf{IntCat}(\mathfrak{M})$, see Section 3.3.2.

†) $\widehat{F} : \mathbf{Comon}^{co}(\mathfrak{M}) \longrightarrow \mathbf{Bicomod}^{op}(\mathfrak{M})$, is defined by the identity on the 0-cells and for the 1-cells $f : C \longrightarrow D$ as ${}^fC^{op} : C \longrightarrow D$ and the 2-cells, $\alpha : {}^fC \longrightarrow {}^gC$ as the image under \widehat{F} of α^{co} . This definition gives $\mathbf{KL}_{\widehat{F}}(\mathbf{Bicomod}^{op}(\mathfrak{M}))$ as the image under $\widehat{\Phi}$ of $\mathbf{IntCat}^{co}(\mathfrak{M})$, see Section 3.3.2.

†) $G : \mathbf{Comon}^{coop}(\mathfrak{M}) \longrightarrow \mathbf{Bicomod}(\mathfrak{M})$, is defined yet again as the identity on the 0-cells and for the 1-cells $f^{op} : C \longrightarrow D$ as ${}^fD : C \longrightarrow D$ and for the 2-cells, $\alpha : {}^fD \longrightarrow {}^gD$ as the image under G of α^{co} . This definition renders $\mathbf{KL}_G(\mathbf{Bicomod}(\mathfrak{M}))$ as the image under Ψ of $\mathbf{IntCoCat}(\mathfrak{M})$,

see Section 3.3.2.

The relation between the alternative method suggested as before and the bifunctors developed in Section 3.3.2 can be understood by the following commutative diagram of locally full and faithful bifunctors, defined as the identity on 0-cells,

$$\begin{array}{ccc}
 \mathbf{KL}_F(\mathcal{B}) & \longrightarrow & \mathbf{KL}(\mathcal{B}) \\
 \uparrow & \nearrow & \\
 \mathbf{M}(\mathcal{B}') & &
 \end{array}$$

3.3.3 Wreaths in $\mathbf{IntCat}(\mathfrak{M})$

In this section the composite 2-functor $\mathbf{Comp}_A : \mathbf{KL}(\mathbf{KL}(\mathcal{A})) \longrightarrow \mathbf{KL}(\mathcal{A})$ is used in order to get the explicit form of the Kleisli objects corresponding to the wreaths in $\mathbf{KL}(\mathcal{A})$. In general, these wreaths will come from monads in the domain 2-category $\mathbf{M}(\mathcal{B}')$ of the locally full embedding bifunctor F , see Section 3.3.2. Then through the 2-functor \mathbf{Comp} , the composite monad will serve as a Kleisli object, first in the 2-category $\mathbf{KL}(\mathcal{A})$ and then, in the domain 2-category $\mathbf{M}(\mathcal{B}')$ as already explained.

3.3.3.1 Kleisli Objects in $\mathbf{IntCat}(\mathfrak{M})$

Above, the bifunctor $\Phi : \mathbf{IntCat} \longrightarrow \mathbf{KL}(\mathbf{Bicomod}(\mathfrak{M}))$ was constructed, which is a locally full embedding. The image of a monad (f, μ, η^f) , over (A, C) , under this bifunctor is the following wreath

$$\begin{aligned}
 (\Phi(A, C), \Phi(f), \Phi(\mu), \Phi(\eta^f)) = & ((C, A), \\
 & (C^f, (C^f \square_C f_1) \cdot \iota_f \cdot {}^C \tilde{\rho}_{Af}), \\
 & (C^f \square_C \mu) \cdot \iota_f^{ff} \cdot \tilde{\Delta}_C^{ff}, \\
 & (C^f \square_C \eta^f) \cdot \iota_f \cdot \tilde{\Delta}_C) . \tag{3.26}
 \end{aligned}$$

Therefore the Kleisli object for the wreath $\Phi(f, \mu, \eta^f)$ is given by the composite monad over C . This composite monad is, in particular, an internal category because it is a 0-cell in $\mathbf{KL}(\mathbf{Bicomod}(\mathfrak{M}))$, see Remark 3.3.1.1. The explicit form of the Kleisli object is $(C, C^f \square_C A, \mu^c, (C^f \square_C \eta^f) \cdot \iota_f \cdot \tilde{\Delta}_C)$ and $\mu^c : C^f \square_C A \square_C C^f \square_C A \longrightarrow C^f \square_C A$ is given, according to (2.31), by

$$(C^f \square_C m_A) \cdot (((C^f \square_C \mu^f) \cdot \iota_f \cdot \tilde{\Delta}_C^{ff}) \square_C A) \cdot (C^f \square_C C^f \square_C m_A) \cdot (C^f \square_C ((C^f \square_C f_1) \cdot \iota_f \cdot {}^C \tilde{\rho}_{Af}) \square_C A) .$$

This is nothing but the morphism m_f in (3.9). The complete internal category structure is precisely the one defined in Section 3.2.2.1, as expected.

3.3.3.2 CoKleisli Objects in $\mathbf{IntCat}(\mathfrak{M})$

In order to get the coKleisli objects in $\mathbf{IntCat}(\mathfrak{M})$, we use in this section the bifunctor $\widehat{\Phi} : \mathbf{IntCat}^{co}(\mathfrak{M}) \longrightarrow \mathbf{KL}(\mathbf{Bicomod}^{op}(\mathfrak{M}))$. The 2-category $\mathbf{IntCat}^{co}(\mathfrak{M})$ has been used here because a monad in it defines a comonad in $\mathbf{IntCat}(\mathfrak{M})$, through the duality. The bifunctor $\widehat{\Phi}$ is a locally full embedding, hence by using it we can obtain the coKleisli objects in $\mathbf{IntCat}(\mathfrak{M})$.

Let $(g, \delta, \varepsilon^g)$ be a comonad over (A, C) , its image $\widehat{\Phi}(g, \delta, \varepsilon^g)$ renders the following wreath in $\mathbf{KL}(\mathbf{Bicomod}^{op}(\mathfrak{M}))$:

$$\begin{aligned} (\Phi(A, C), \Phi(g), \Phi(\delta), \Phi(\varepsilon^g)) = & ((C, A), \\ & ({}^g C, (g_1 \square_C {}^g C) \cdot {}^g \iota_g \cdot {}^g \tilde{\rho}_A^C), \\ & (\delta \square_C {}^g C) \cdot {}^{gg} \iota_g \cdot {}^{gg} \tilde{\Delta}_C, \\ & (\varepsilon^g \square_C {}^g C) \cdot \iota_g \cdot \tilde{\Delta}_C) . \end{aligned} \quad (3.27)$$

Therefore the coKleisli object for the wreath $\widehat{\Phi}(g, \delta, \varepsilon^g)$ is also given by the composite monad over C , which is an internal category and it is explicitly given by $(C, A \square_C {}^g C, \mu^c, (\varepsilon^g \square_C {}^g C) \cdot \iota_g \cdot \tilde{\Delta}_C)$ and $\mu^c : A \square_C {}^g C \square_C A \square_C {}^g C \longrightarrow A \square_C {}^g C$, according to (2.31), is

$$(m_A \square_C {}^g C) \cdot (A \square_C ((\delta^g \square_C {}^g C) \cdot {}^{gg} \iota_g \cdot {}^{gg} \tilde{\Delta}_C)) \cdot (m_A \square_C {}^g C \square_C {}^g C) \cdot (A \square_C ((g_1 \square_C {}^g C) \cdot {}^g \iota_g \cdot {}^g \tilde{\rho}_A^C) \square_C {}^g C) .$$

This morphism is the same as m_g in (3.23). The complete internal category structure is the same as the one given in Section 3.2.3.

3.3.3.3 Kleisli Objects in $\mathbf{IntCoCat}(\mathfrak{M})$

The procedure developed for the both of the previous examples is extended to the case of cofunctors. This procedure can be applied to this case also because of the existence of the bifunctor $\Psi : \mathbf{IntCoCat}(\mathfrak{M}) \longrightarrow \mathbf{KL}(\mathbf{Bicomod}^{op}(\mathfrak{M}))$. Therefore, if there exists a monad (f, μ, η^f) , over (A, C) , in $\mathbf{IntCoCat}(\mathfrak{M})$, its image $\Psi(f, \mu, \eta^f)$ renders the following wreath in $\mathbf{KL}(\mathbf{Bicomod}(\mathfrak{M}))$

$$(\Psi(A, C), \Psi(f), \Psi(\mu), \Psi(\eta^f)) = ((C, A), ({}^f C, f_1), ({}^f C \tilde{\rho}_A \cdot \mu, ({}^f C \tilde{\rho}_A \cdot \eta^f)) . \quad (3.28)$$

The Kleisli object for the wreath $\Psi(f, \mu, \eta^f)$ is given, yet again, by the composite monad over C . This composite monad is $(C, {}^f C \square_C A, \mu^c, ({}^f C \tilde{\rho}_A \cdot \eta^f))$, where μ^c is given by

$$({}^f C \square_C m_A) \cdot (({}^f C \tilde{\rho}_A \cdot \mu) \square_C A) \cdot ({}^f C \square_C {}^f C \square_C m_A) \cdot ({}^f C \square_C f_1 \square_C A) . \quad (3.29)$$

As mentioned earlier, the conclusion that $\mathbf{IntCoCat}(\mathfrak{M})$ admits Kleisli objects is one important result obtained with this procedure.

3.4 String Diagrams

In Section 3.2.1 the Sweedler notation was explained in order to use it as a tool to compute with morphisms in a monoidal category $(\mathfrak{M}, \otimes, I)$. In this section, another tool to compute with morphisms in a monoidal category is explained, the so-called method of *string diagrams*. Due to Remark 1.5.1.1, that a monoidal category can be seen as a special case of a 2-category, the tool of string diagrams applied usually to 2-categories and bicategories, can also be used in monoidal categories. In the general case, the n -cell notation for a 2-category, used so far in this thesis, is Poincare dual to the string notation.

The topological background on which this technique relies on will be omitted for the sake of brevity and this thesis will only focus on the operational description of the method. The references that are closer to the notation and depiction of diagrams are [4], [14], [17]. We start the operational description by giving examples of this particular representation of morphisms in the bicategory $\mathbf{Bicomod}(\mathfrak{M})$.

Let M and N be C -comodules, then we represent the following morphisms using string diagrams as follows

$$1_M = \begin{array}{c} M \\ | \\ M \end{array}, \quad f = \begin{array}{c} M \\ | \\ \bullet \\ | \\ N \end{array} f, \quad g \cdot f = \begin{array}{c} M \\ | \\ \bullet \\ | \\ \bullet \\ | \\ M' \end{array} \begin{array}{c} f \\ g \end{array}, \quad f \square_C h = \begin{array}{c} M \\ | \\ \bullet \\ | \\ N \end{array} f \quad \begin{array}{c} M' \\ | \\ \bullet \\ | \\ N' \end{array} h.$$

For a comonoid $(C, \Delta_C, \varepsilon)$, we have that the induced comultiplication $\tilde{\Delta}_C$ is depicted as

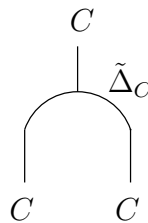

and its coassociativity as

For a C -comodule $(M, {}^C\tilde{\rho}_M, \tilde{\rho}_M^C)$, the coactions are drawn as

For the morphism $\iota_f : M \square_C N \longrightarrow M^f \square_C^f N$ given by the commutative diagram in (1.13), the corresponding string diagram is the following one

There is one important property that needs to be highlighted because it will appear in all the future calculations. This property is related to the equalizer property of $M \square_C N$ under the parallel morphisms $M \otimes {}^C\rho_N$ and $\rho_M^C \otimes N$, for C -comodules M and N . This property is drawn as

If M is still a C -comodule and N is now a D -comodule, along with a comonoid morphism $f_0 : C \longrightarrow D$, then this equality can be translated, for the right D -comodule $(M^f, (M \otimes f_0) \cdot \rho_M^C)$, to

Finally, for a monoid (A, m_A, u_A) in ${}^C\mathcal{M}^C$, the morphisms m_A and u_A are represented by

Just in the same way as we did for the Sweedler notation in Section 3.2.1, we omit further details and without further ado we proceed to show the usefulness of the method of string diagrams in action.

3.5 Binatural Maps and Adjunctions in $\mathbf{IntCat}(\mathfrak{M})$

This section is based on [10]. In [25], there are two equivalent definitions for an adjunction $L \dashv R$, the first one is through the existence of a unit and a counit and the other one through the bijection

$$\mathit{Hom}_{\mathcal{C}}(A, RB) \cong \mathit{Hom}_{\mathcal{D}}(LA, B) , \quad (3.31)$$

for all A in \mathcal{C} and B in \mathcal{D} . This requirement can be interpreted in terms of internal categories as follows. Consider the adjunction (2.11), for the Kleisli category \mathcal{C}_F , then as above, this gives a bijection $\mathit{Hom}_{\mathcal{C}}(A', FB') \cong \mathit{Hom}_{\mathcal{C}_F}(A', B')$. On the other hand, in the previous sections, the Kleisli object for a monad (f, μ, η^f) over (A, C) was found to be $(C, C^f \square_C A)$, hence a comparison between the object of morphisms $C^f \square_C A$ and the class of arrows or morphisms of a Kleisli category $\mathit{Hom}_{\mathcal{C}}(A', FB')$ can be given. This provides an insight in how to manipulate adjunctions within internal categories.

Take an adjunction $l \dashv r$ in the 2-category $\mathbf{IntCat}(\mathfrak{M})$, as in (3.1), then the left-hand side of (3.31), can be interpreted as $D^r \square_C A$ and the right-hand side as $B \square_D {}^l C$. In order to get the complete translation of this classic requirement for classical categories in terms of internal ones, the following definition has to be stated.

Definition 3.5.1. Let $l : (A, C) \longrightarrow (B, D)$ and $r : (B, D) \longrightarrow (A, C)$ be a pair of internal functors. Then a D - C -bicomodule map

$$\theta : D^r \square_C A \longrightarrow B \square_D^l C , \quad (3.32)$$

is said to be binatural if and only if the following diagrams commute

$$\begin{array}{ccc} B^r \square_C A & \xrightarrow{\tilde{\rho}_B^{D^r \square_C A}} & B \square_D D^r \square_C A \xrightarrow{B \square_D \theta} B \square_D B \square_D^l C \\ \downarrow D \tilde{\rho}_B^{r \square_C A} & & \downarrow m_B \square_D^l C \\ D \square_D B^r \square_C A & & \\ \downarrow D \square_D r_1 \square_C A & & \\ D^r \square_C A \square_C A & \xrightarrow{D^r \square_C m_A} & D^r \square_C A \xrightarrow{\theta} B \square_D^l C \end{array} , \quad (3.33)$$

$$\begin{array}{ccc} D^r \square_C A \square_C A & \xrightarrow{\theta \square_C \tilde{\rho}_A^C} & B \square_D^l C \square_C A \square_C C \xrightarrow{B \square_D u_B l_0 \square_C l_1 \square_D^l C} B \square_D B \square_D B \square_D^l C \\ \downarrow D^r \square_C m_A & & \downarrow m_B^2 \square_D^l C \\ D^r \square_C A & \xrightarrow{\theta} & B \square_D^l C \end{array} . \quad (3.34)$$

With this definition at hand, the requirement for an adjunction in $\mathbf{IntCat}(\mathfrak{M})$, c.f. (3.1), can have an equivalent characterization resembling that of (3.31).

Theorem 3.5.2. Let $l : (A, C) \longrightarrow (B, D)$ and $r : (B, D) \longrightarrow (A, C)$ be a pair of internal functors. The adjunction $l \dashv r$ takes place if and only if $D^r \square_C A \cong B \square_D^l C$ through binatural maps of D - C -bicomodules.

Proof:

Suppose that $l \dashv r$ is an adjunction. We claim that the binatural isomorphism is given by

$$\theta = (m_B \square_D^l C) \cdot (\varepsilon \square_D l_1 \square_D^l C) \cdot \iota_l^2 \cdot (D^r \square_D \tilde{\rho}_A^C) : D^r \square_C A \longrightarrow B \square_D^l C , \quad (3.35)$$

and its binatural inverse is

$$\theta^{-1} = (D^r \square_C m_A) \cdot (D^r \square_C r_1 \square_C \eta) \cdot \iota_r^2 \cdot (D \tilde{\rho}_B \square_D^l C) : B \square_D^l C \longrightarrow D^r \square_C A . \quad (3.36)$$

That θ and θ^{-1} are D - C -bicomodule maps follows by the respective bi-linearity of each of their composite morphisms. The rest of the prove is done by using string diagrams. First, the binaturality of θ is proved by checking the commutativity of the diagrams, (3.33) and (3.34). The proof starts by translating the upper-right branch of the commutative diagram (3.33) as a string diagram:

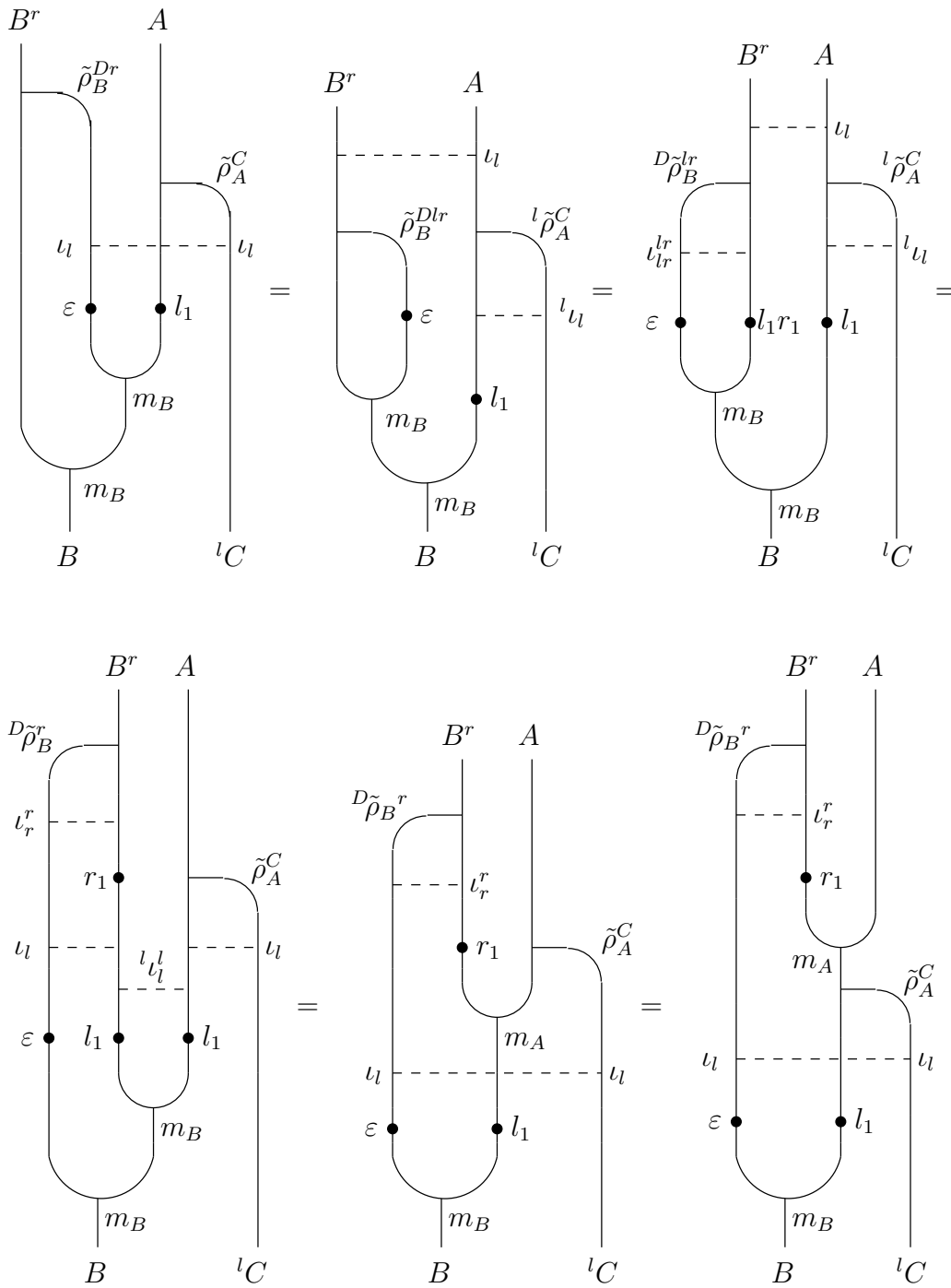

This last string diagram is the one corresponding to the left-lower branch of the diagram (3.33) as it was required. In the first equality of the previous string calculation the associativity for m_B

was used. The second equality follows by the naturality of ε . In the third equality, the bifunctionality of the cotensor product along with the associativity of m_B were used. For the fourth equality, the multiplicativity of l_1 was used. Finally, for the fifth equality the right C -colinearity of m_A was used.

The next string diagram shows the commutativity of the second requirement (3.34) for the binaturality of θ

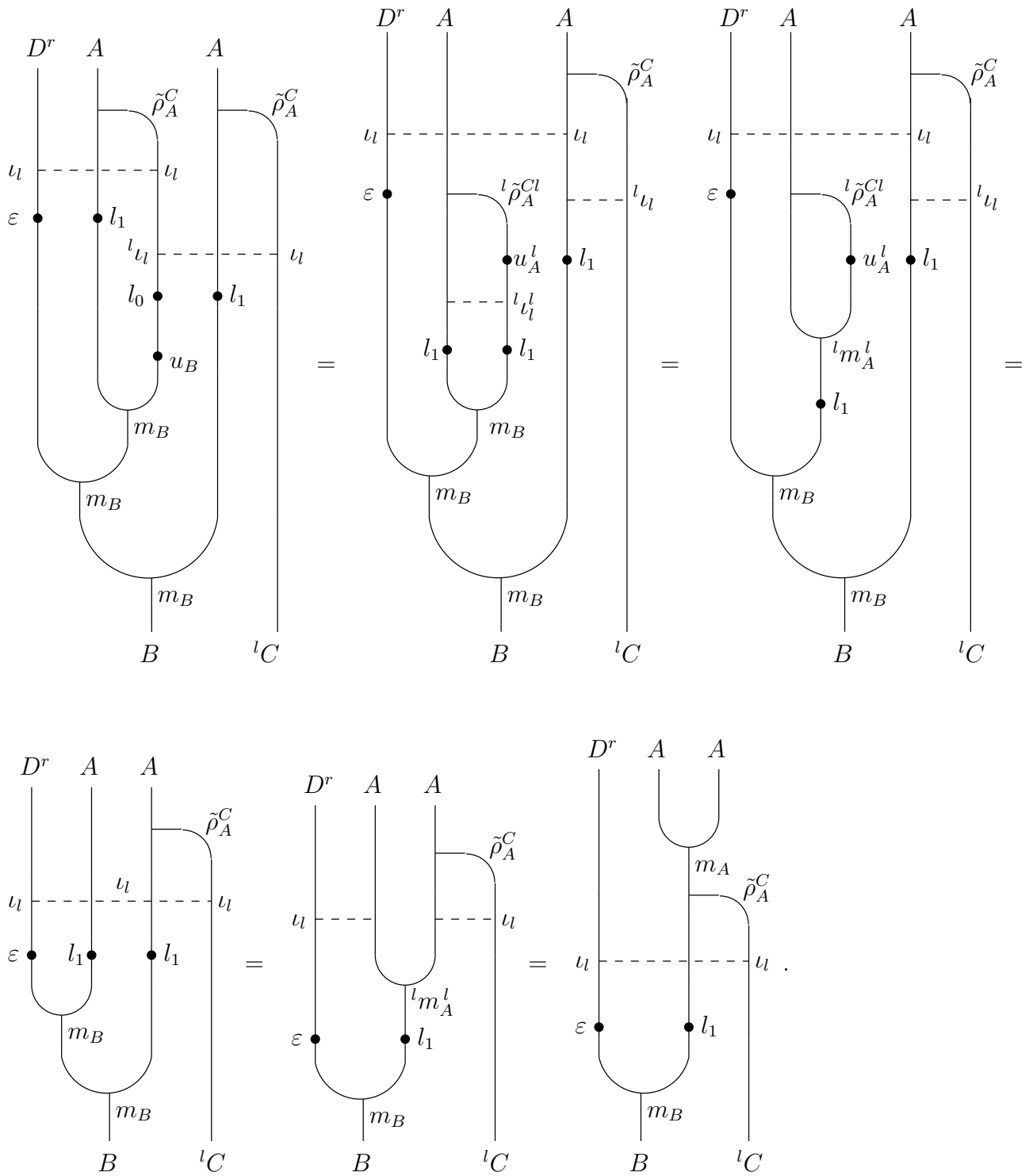

In the previous string calculation, the following steps were carried out. In the first equality, the functoriality of the cotensor product along with the equality $u_B \cdot l_0 = l_1 \cdot u_A$ were used. In the second equality, the multiplicativity of l_1 was used. In the third equality, the unitality of u_A was used only. In the fourth equality, the associativity of m_B and the multiplicativity of l_1 were used one after the other. Finally, in the fifth equality, the right C -colinearity of m_A was used.

The binaturality of θ^{-1} is proved by a mirror reflexion of the proof just given and by renaming the involved morphisms, *i.e.* by changing l_1 for r_1 , ε for η , m_B for m_A and so on.

The proof for the equality $\theta \cdot \theta^{-1} = 1_{B \square_D {}^l C}$ starts by translating the left-hand side of the equality using string diagrams:

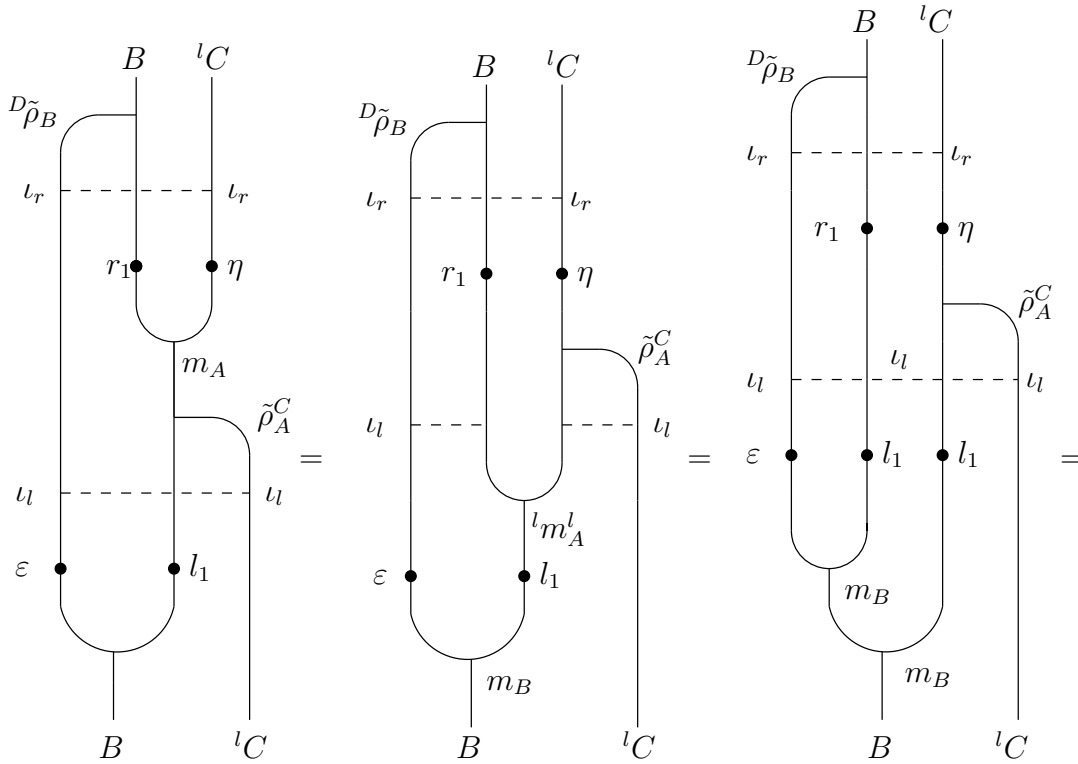

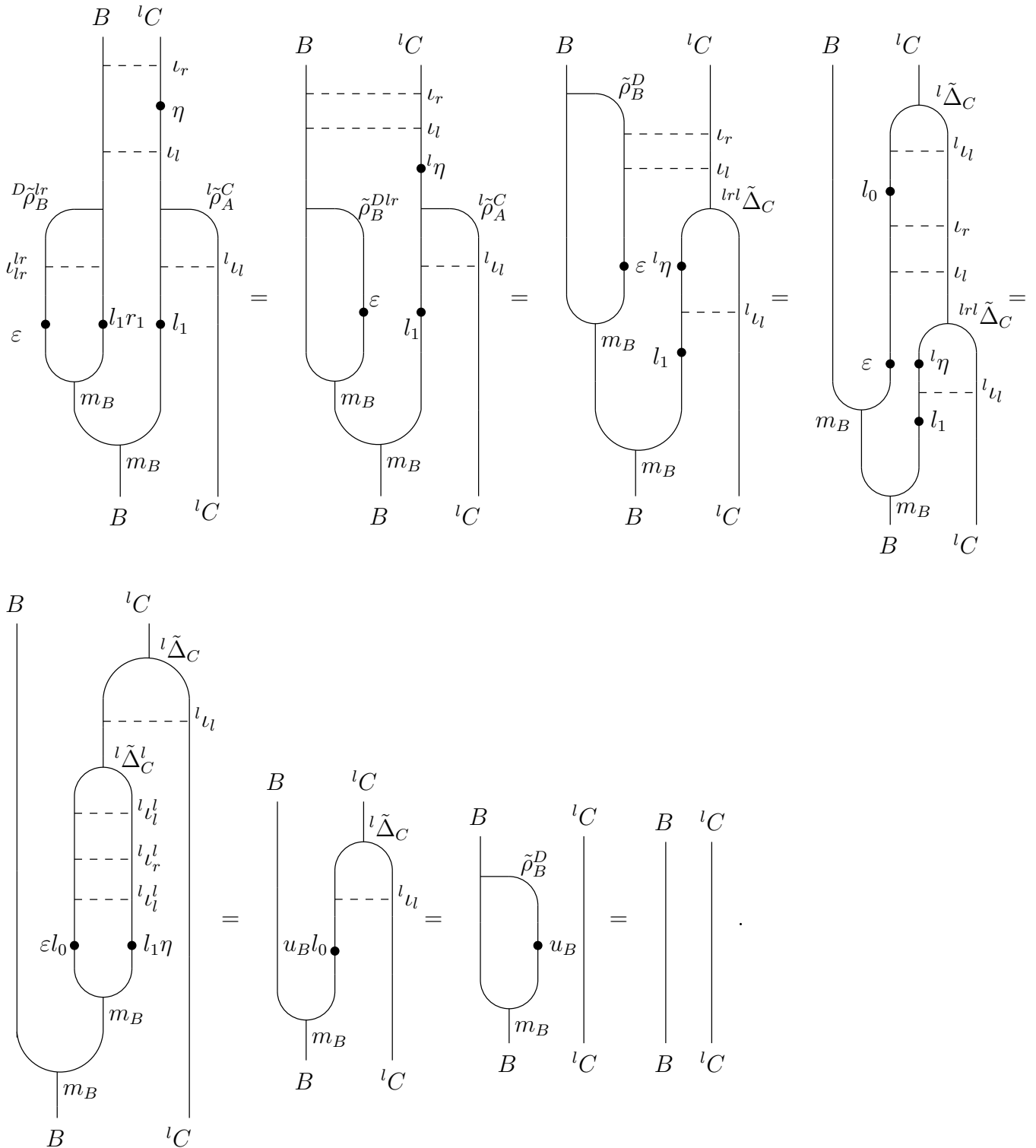

This string calculation was performed as follows. In the first equality the right C -colinearity of m_A was used. In the second equality the multiplicativity of m_A and the associativity of m_B were used at once. In the third equality, just the functoriality of the cotensor product was used to move the morphisms up and down. In the fourth equality, the naturality of ε was used. In the fifth one, the left C -colinearity of η was used instead. In the sixth equality, the property in (3.30) was used. The seventh equality follows by the coassociativity of Δ_C and the functoriality

of the cotensor product, which allow us to move the strings. In the eighth equality, the triangular identity associated to the left adjoint l was used. In the ninth equality, the property (3.30) was used yet again. Finally, in the tenth equality, the unitality of u_B was used.

The proof of the equality $\theta^{-1} \cdot \theta = 1_{D^r \square_C A}$ can be performed by a mirror reflexion on the one just given and by renaming the involved morphisms as before. Therefore, for this proof one uses the multiplicativity of r_1 , the naturality of η and the triangular identity associated with the right adjoint r .

Conversely, suppose that there is a D - C -bicomodule isomorphism $\theta : D^r \square_C A \longrightarrow B \square_D {}^l C$ with inverse θ^{-1} . The induced unit and counit for the *a posteriori* adjunction are defined as follows:

$$\eta = m_A \cdot (u_A r_0 \square_C A) \cdot \theta^{-1} \cdot (u_B l_0 \square_D {}^l C) \cdot \iota_l \cdot \tilde{\Delta}_C : C \longrightarrow A , \quad (3.37)$$

$$\varepsilon = m_B \cdot (B \square_D u_B l_0) \cdot \theta \cdot (D^r \square_C u_A r_0) \cdot \iota_r \cdot \tilde{\Delta}_D : D \longrightarrow B . \quad (3.38)$$

That $\eta : {}^r l C \longrightarrow A$ is a C -bicomodule morphism follows from the fact that the composition $\iota_l \cdot \tilde{\Delta}_C$ can be mapped, using the functor ${}^r l F$, to the following C -bicomodule morphism ${}^r l \iota_l \cdot {}^r l \tilde{\Delta}_C$; the composition $\theta^{-1} \cdot (u_B l_0 \square_D {}^l C)$ can be mapped through the functor ${}^r F$, to the following C -bicomodule morphism, ${}^r \theta^{-1} \cdot ({}^r (u_B l_0) \square_D {}^l C)$; the previous two compositions can be composed also with the following C -bicomodule map $m_A \cdot (u_A r_0 \square_C A)$ which gives the definition of η . That $\varepsilon : {}^l r D \longrightarrow B$ is a D -bicomodule map follows in the same way.

Before going into the proof of the naturality of η , the string diagrams for the binaturality of θ^{-1} have to be drawn. For (3.33) and (3.34) we have

(3.39)

respectively. The last string diagram will be used not in this form but the one after composing with $m_A \cdot (u_A r_0 \square_C A)$, which results in the following equality of string diagrams

(3.40)

With these string diagram equalities at hand, the naturality of η can now be proved.

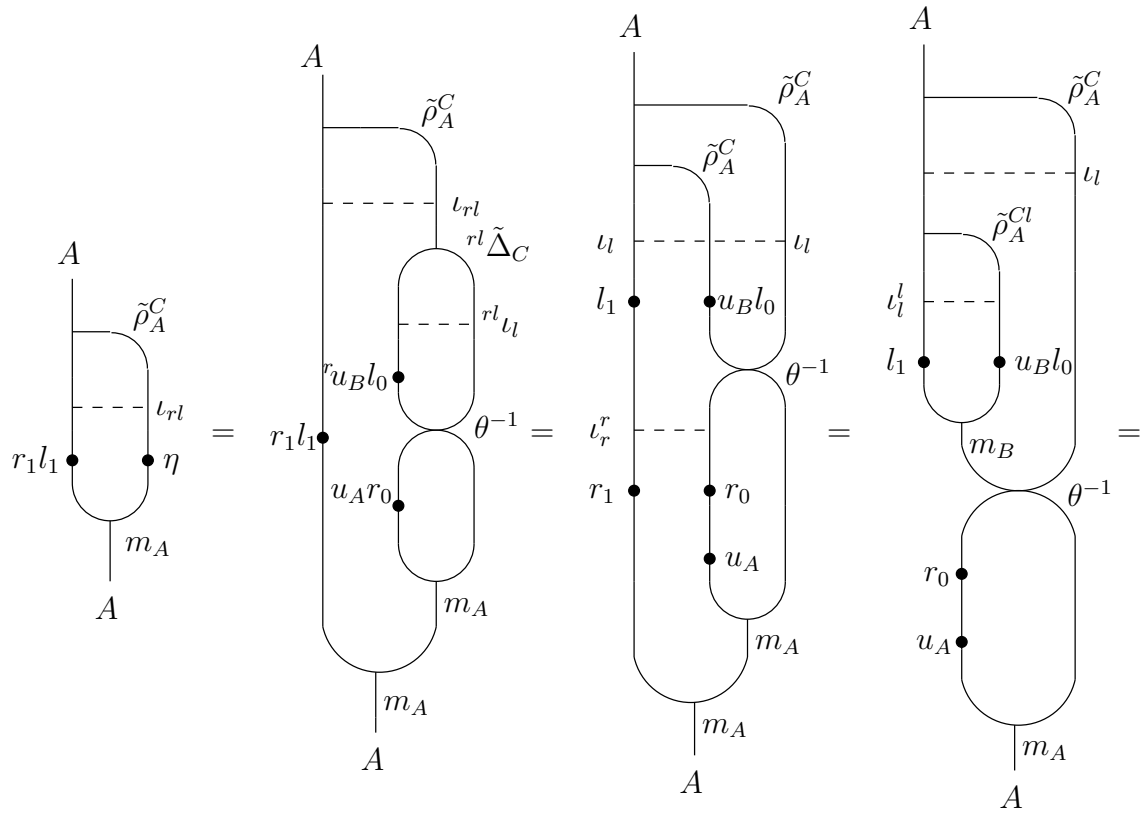

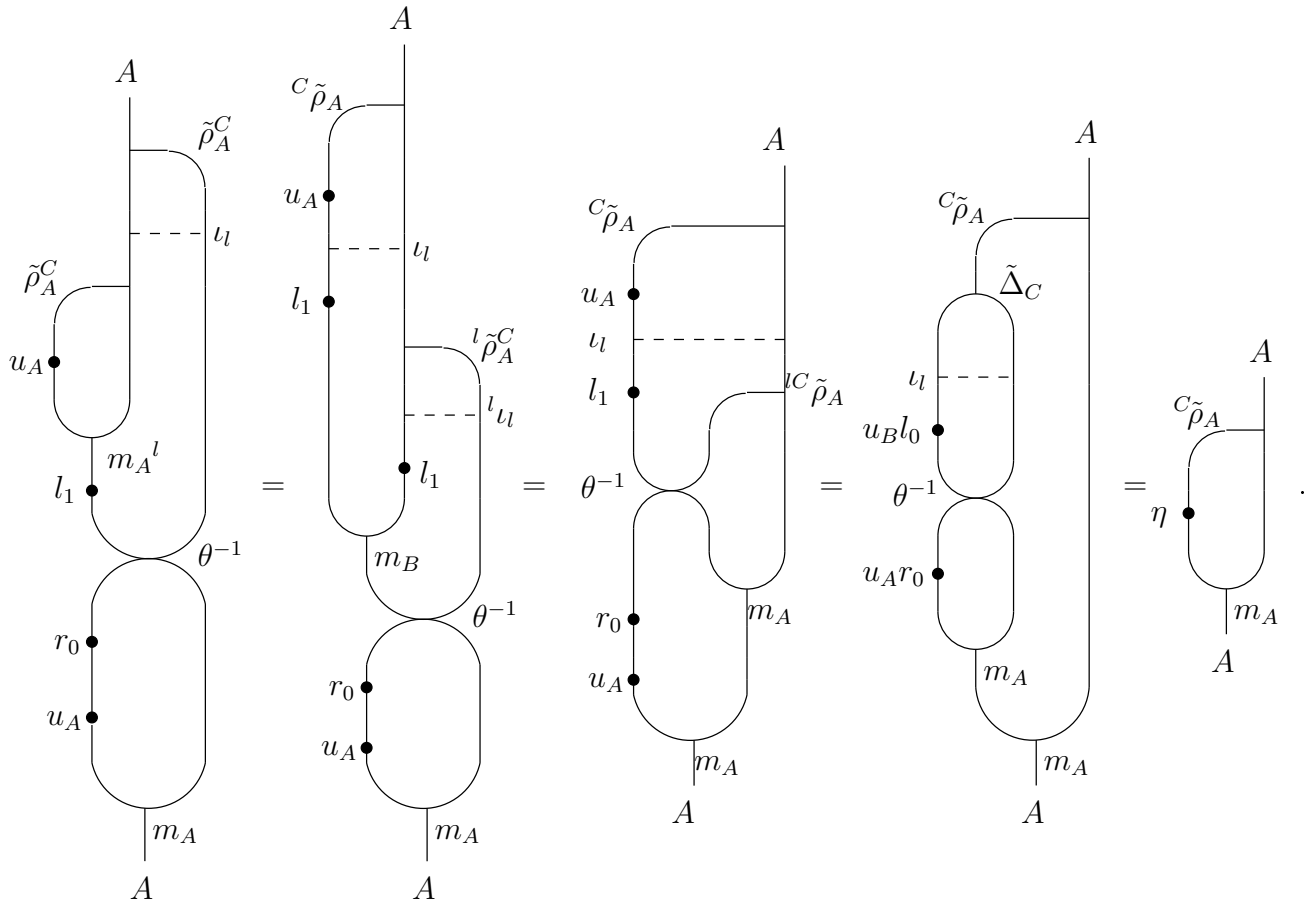

In the previous string calculation, the following steps were carried out. In the first equality, the definition of η was taken. In the second equality, the property (3.30) was used. In the third equality, (3.40) was used. The fourth equality follows by the multiplicativity of l_1 and the unitality of u_A . In the fifth equality, the multiplicativity of l_1 and the functoriality of the cotensor product to move strings up and down were used. In the sixth equality, the first requirement for the binaturality of θ^{-1} , (3.39), was used. In the seventh equality, the associativity of m_A along with (3.30) were used. Finally, in the eighth equality, the definition of η was applied.

The naturality of ε is proved by symmetrical steps as the ones carried out.

As far as the triangular identities go, the one associated with the left adjoint l , namely $\varepsilon l_0 * l_1 \eta = 1_l = u_B l_0$, is proved as follows. Applying the definition of the unit η and the counit ε in terms of θ and θ^{-1} , we start by

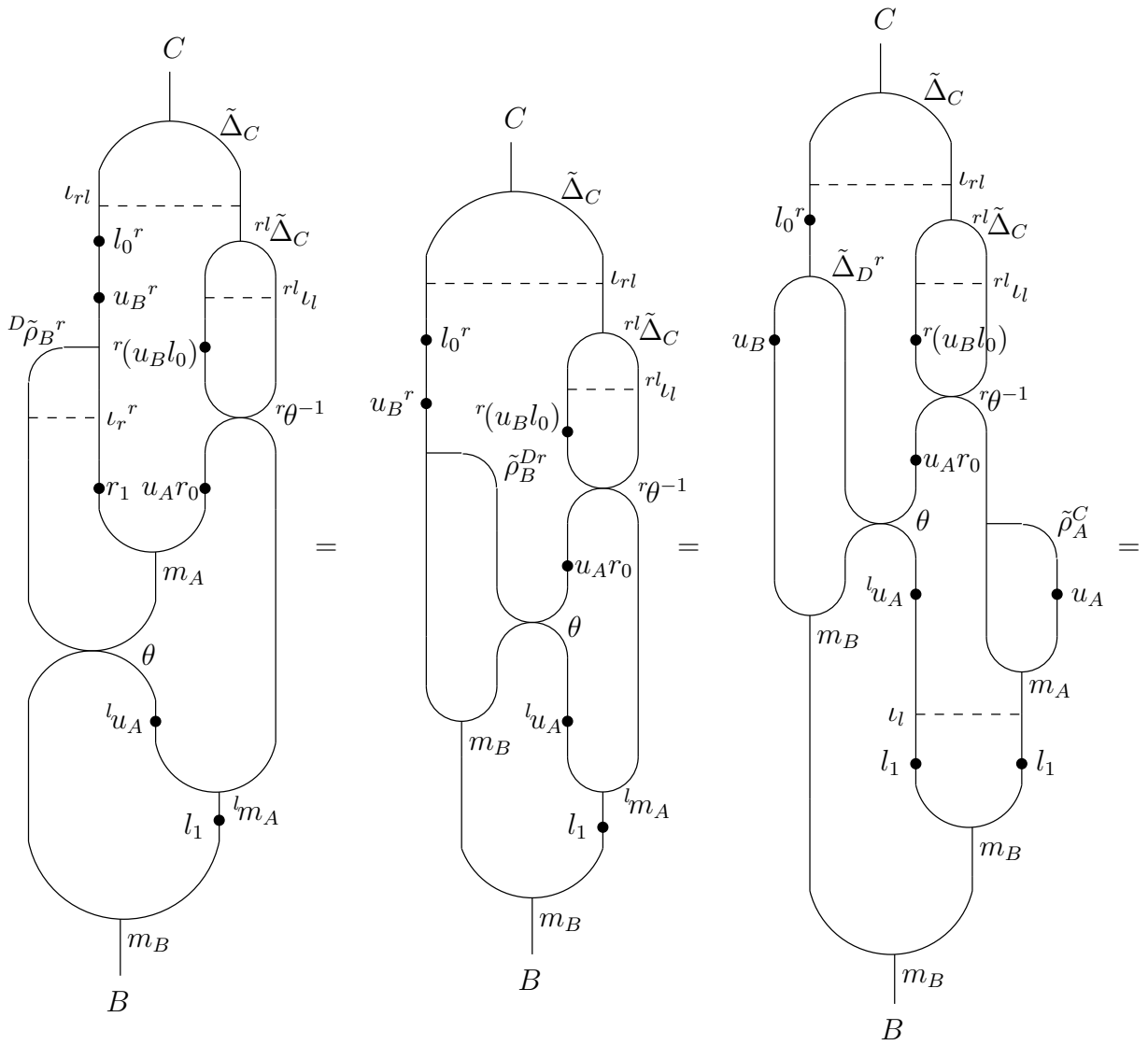

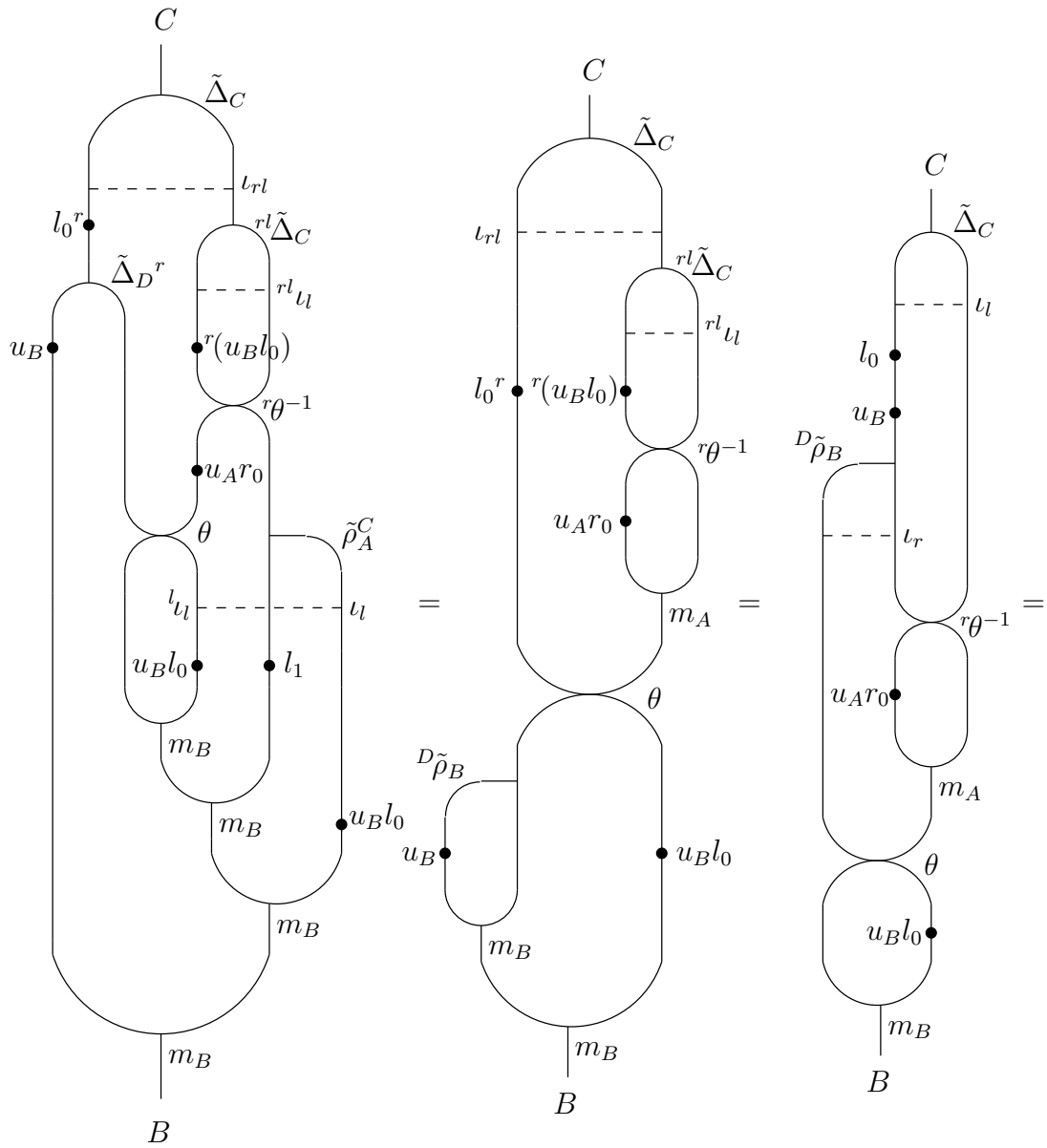

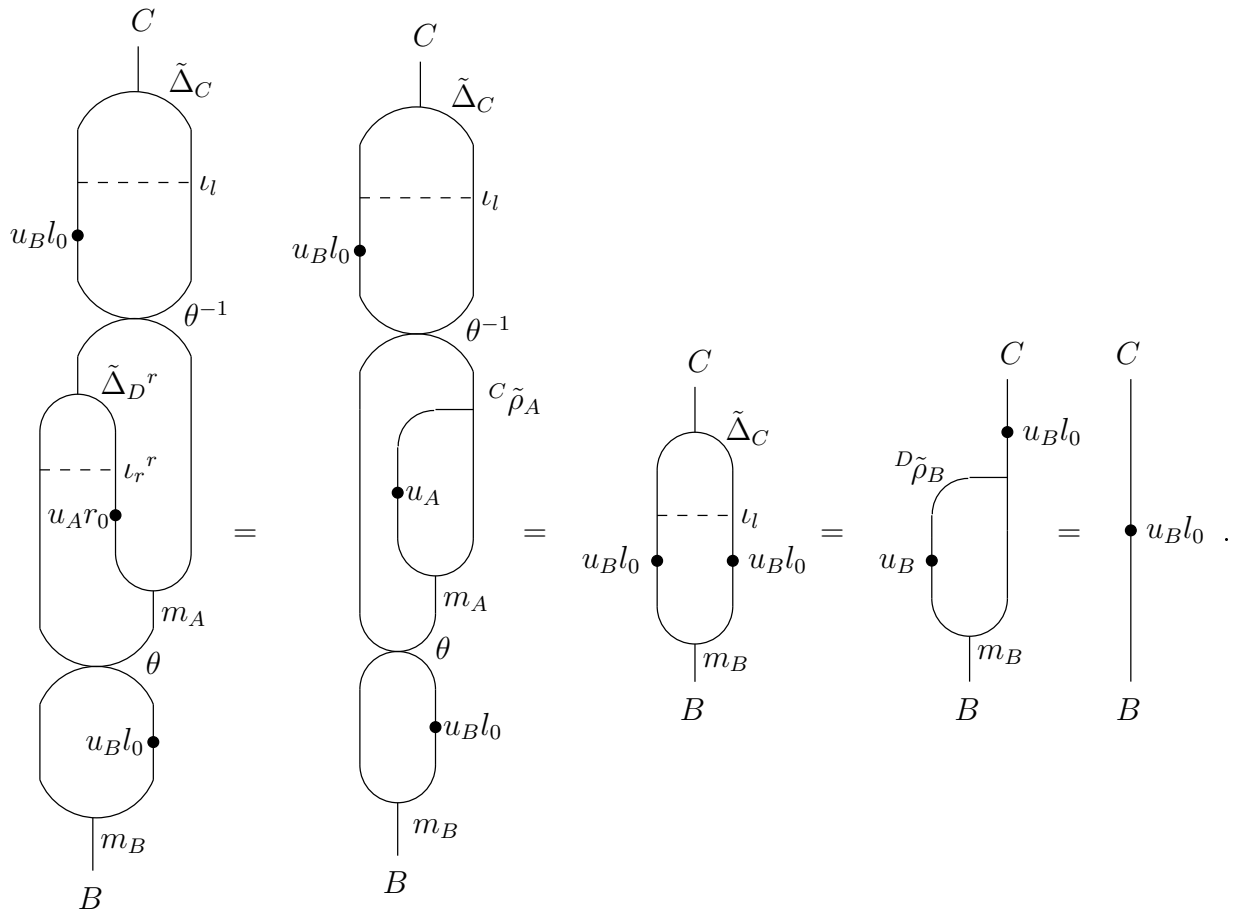

The first equality follows by the unitality of u_A . In the second equality, the multiplicativity of l_1 and the associativity of m_A and m_B were used. In the third equality, the second requirement for θ being a binatural map, (3.34), and the left colinearity of u_B were used. For the fourth one, the first requirement for the binaturality of θ , (3.33), was used only. For the fifth equality, the right colinearity of u_B and the unitality of u_A were used. For the sixth equality the multiplicativity of l_1 and the associativity of m_B were used. For the seventh, the left D -colinearity of θ was used. For the eighth equality, the left colinearity of u_B and the coassociativity of Δ_C were used. For the ninth equality, the left D -colinearity of θ^{-1} was used only. For the tenth one, property (3.30) was used. For the eleventh equality, the unitality of u_A and the fact that θ^{-1} is the inverse for θ were used. For the twelfth equality, the fact that l_0 is a comonoid map along with the left colinearity of u_B were used. For the last equality, the unitality of u_B was used.

The other triangular equality, the one associated with the right adjoint r , is done symmetrically as this one. This concludes the proof. \square

3.5.1 Alternative Proof of the Characterization of Adjunctions

In [6], G. Böhm suggested another proof of the characterization of adjunctions in $\mathbf{IntCat}(\mathfrak{M})$ using the locally full embedding bifunctor $\Phi : \mathbf{IntCat}(\mathfrak{M}) \longrightarrow \mathbf{KL}(\mathbf{Bicomod}(\mathfrak{M}))$. This proof requires the following introduction.

Let \mathcal{B} be a bicategory, and consider the following pair of 1-cells in $\mathbf{KL}(\mathcal{B})$

$$(A, f) \begin{array}{c} \xleftarrow{(r, \psi)} \\ \xrightarrow{(l, \varphi)} \end{array} (A', h) \quad . \quad (3.41)$$

In particular, l is a 1-cell in \mathcal{B} . Suppose further that in \mathcal{B} , k is a right adjoint to l ,

$$A \begin{array}{c} \xleftarrow{k} \\ \xrightarrow{l} \end{array} A' \quad , \quad (3.42)$$

with unit $\nu : 1_A \longrightarrow kl$ and counit $\zeta : lk \longrightarrow 1_{A'}$. Then there is a bijective correspondence between adjunctions $(l, \varphi) \dashv (r, \psi)$ and isomorphic 2-cells

$$\theta : fr \longrightarrow kh \quad , \quad (3.43)$$

satisfying the following equalities

$$\theta \circ \mu^f r = k\mu^h \circ (kh\zeta h) \circ (k\varphi kh) \circ (\nu fkh) \circ f\theta \quad , \quad (3.44a)$$

$$k\mu^h \circ \theta h = \theta \circ \mu^f r \circ f\psi \quad . \quad (3.44b)$$

In this section Theorem 3.5.2 is restated and reproved using the above characterization of adjunctions.

Theorem 3.5.1.1. *Let $l : (A, C) \longrightarrow (B, D)$ and $r : (B, D) \longrightarrow (A, C)$ be a pair of internal functors. The adjunction $l \dashv r$ takes place if and only if $D^r \square_C A \cong B \square_D {}^l C$ through binatural maps of D - C -bicomodules.*

Proof:

The bicategory \mathcal{B} is taken as the bicategory $\mathbf{Bicomod}(\mathfrak{M})$. Then, due to the locally full embedding $\Phi : \mathbf{IntCat}(\mathfrak{M}) \longrightarrow \mathbf{KL}(\mathbf{Bicomod}(\mathfrak{M}))$, constructed in Section 3.3.2, an adjunction

$$(A, C) \begin{array}{c} \xleftarrow{r} \\ \xrightarrow{l} \end{array} (B, D) \quad , \quad (3.45)$$

in $\mathbf{IntCat}(\mathfrak{M})$ can be taken to be an adjunction in $\mathbf{KL}(\mathbf{Bicomod}(\mathfrak{M}))$,

$$(C, A) \begin{array}{c} \xleftarrow{(D^r, \phi_r)} \\ \xrightarrow{(C^l, \phi_l)} \end{array} (D, B) \quad . \quad (3.46)$$

On the other hand, $C^l \dashv {}^l C$ in $\mathbf{Bicomod}(\mathfrak{M})$, with unit $\iota_l \cdot \tilde{\Delta}_C : C \longrightarrow C^l \square_C {}^l C$ and counit $l_0 \cdot {}^l \xi^l : {}^l C \square_C C^l \longrightarrow D$, where $\xi : C \square_C C \longrightarrow C$ is an isomorphism.

Then according to [6], there is a bijective correspondence between adjunctions $(C^l, \phi_l) \dashv (D^r, \phi_r)$ in $\mathbf{KL}(\mathbf{Bicomod}(\mathfrak{M}))$, or because of Φ between adjunctions $l \dashv r$ in $\mathbf{IntCat}(\mathfrak{M})$, and isomorphic 2-cells

$$\theta : D^r \square_C A \longrightarrow B \square_D {}^l C \quad ,$$

satisfying the following equalities in $\mathbf{Bicomod}(\mathfrak{M})$

$$\begin{aligned} \theta \cdot (D^r \square_C m_A) &= (m_B \square_D {}^l C) \cdot (B \square_D (l_0 \cdot \xi) \square_D B \square_D {}^l C) \cdot (B \square_D {}^l C \square_C (l_1 \cdot l'_1 \cdot {}^C \tilde{\rho}_A^l) \square_D {}^l C) \\ &\quad \cdot (B \square_D {}^l C \square_C A \square_C (\iota_l \cdot \tilde{\Delta}_C)) \cdot (\theta \square_C A) \quad , \end{aligned} \quad (3.47a)$$

$$(m_B \square_D {}^l C) \cdot (B \square_C \theta) = \theta \cdot (D^r \square_C m_A) \cdot (((D^r \square_C r_1) \cdot \iota_r^r \cdot {}^D \tilde{\rho}_B^r) \square_C A) \quad . \quad (3.47b)$$

These two equations are equivalent to the binaturality requirements for θ in (3.33) and (3.34), respectively. \square

3.6 Kleisli Objects Induced by Mates under Adjunctions

The following construction is based on [18]. Let

$$(A, C) \begin{array}{c} \xleftarrow{r} \\ \xrightarrow{l} \end{array} (B, D) \quad , \quad (A', C') \begin{array}{c} \xleftarrow{r'} \\ \xrightarrow{l'} \end{array} (B', D') \quad (3.48)$$

be a couple of 2-adjunctions in the 2-category $\mathbf{IntCat}(\mathfrak{M})$ and also let $(h_1, h_0) : (A, C) \longrightarrow (A', C')$ and $(k_1, k_0) : (B, D) \longrightarrow (B', D')$ be two internal functors. Then, because of Proposition 3.1 in [18], there is a bijection between the 2-cells, $\lambda : l'h \longrightarrow kl$ and $\nu : hr \longrightarrow r'k$. This bijection is given through the following 2-diagrams

$$\begin{array}{ccccc} & (A, C) & \xrightarrow{h} & (A', C') & \xrightarrow{1_{(A', C')}} & (A', C') \\ & \nearrow r & & \downarrow \lambda & \searrow l' & \downarrow \eta' \\ (B, D) & \xrightarrow{1_{(B, D)}} & (B, D) & \xrightarrow{k} & (B', D') & \\ & \downarrow \varepsilon & & & \nearrow r' & \end{array} \quad (3.49)$$

$$\begin{array}{ccccc} (A, C) & \xrightarrow{1_{(A, C)}} & (A, C) & \xrightarrow{h} & (A', C') \\ & \searrow l & \downarrow \eta & \nearrow r & \downarrow \nu \\ & (B, D) & \xrightarrow{k} & (B', D') & \xrightarrow{1_{(B', D')}} & (B', D') \\ & & & \nearrow r' & \downarrow \varepsilon' & \searrow l' \end{array} \quad (3.50)$$

If the pasting operation is carried out according to (2.22), then this bijection looks like $\lambda \mapsto r'k\varepsilon \circ r'\lambda r \circ \eta'hr$ and $\nu \mapsto \varepsilon'kl \circ l'\nu l \circ l'h\eta$.

Consider an adjunction $l \dashv r$ with the same domain and codomain (A, C) for the second adjunction in (3.48) and for the first adjunction consider instead the composition of adjunctions $ll \dashv rr$, with unit and counit $r_1\eta l_0 * \eta$ and $\varepsilon * l_1\varepsilon r_0$, respectively, see [25]. In this set up, take $h = 1_{(A, C)}$ and $k = 1_{(A, C)}$. Finally, if the right adjoint r is part of a monad $R = (r, \mu, \eta^r)$ then the bijectivity in (3.49) gives a natural transformation $\delta : l \longrightarrow ll$, out of $\mu : rr \longrightarrow r$.

On the other hand, if the first adjunction is taken now as the identity adjunction on (A, C) , and for the second one the same adjunction $l \dashv r$ as before, then the bijectivity in (3.49) gives a natural transformation $\varepsilon' : l \longrightarrow 1_{(A, C)}$, out of $\eta^r : 1_{(A, C)} \longrightarrow r$. This procedure can be summarized, according to [22], in the following

Proposition 3.6.1. *Let $r : (A, C) \longrightarrow (A, C)$ be an endomorphism that is part of a monad, i.e. $R = (r, \mu, \eta^r)$, and let l be the left adjoint of r . Then there is a comonad structure induced on l , under mating, i.e. $L = (l, \delta, \varepsilon^l)$. The explicit formula for the comultiplication and the counit is $\delta = \varepsilon l_0 l_0 * l_1 \mu l_0 l_0 * l_1 r_1 \eta l_0 * l_1 \eta$ and $\varepsilon^l = \varepsilon * l_1 \eta^r$ respectively, where ε and η are the counit and the unit of the adjunction, respectively. This type of adjunction is denoted by $L \dashv R$. \square*

Note: This proposition was written using the coopposite dual principle over the corresponding proposition in [22].

With an adjunction of this type, there are two induced internal categories, according to the previous sections, $((C^r \square_C A, C) m_r, u_r)$ and $((A \square_C^l C, C), m_l, u_l)$, the Kleisli and coKleisli objects, respectively. This section finishes with an adaptation of Theorem 2.14 in [22],

Theorem 3.6.2. *Let $L \dashv R$ be an adjunction over (A, C) , where $L = (l, \delta, \varepsilon^l)$ is the comonad induced by mating the monad $R = (r, \mu, \eta^r)$, then there exists an internal isomorphism between the induced Kleisli and the coKleisli objects, that is to say, $(C^r \square_C A, C) \cong (A \square_C^l C, C)$.*

3.7 Example

See [10]. In this section the monoidal category that will be used to give an example of adjunctions is the monoidal category $(\mathbf{Mod}_R^{op}, \otimes_R, R)$, see Section 1.4.1. In this section the tensor product \otimes_R will be taken unadorned \otimes . Let us make the following

Definition 3.7.1. *Let A be an R -algebra. An A -coring twisting datum is*

$$(\mathcal{D} \begin{array}{c} \xrightarrow{l} \\ \xleftarrow{r} \end{array} C, \theta) \quad , \quad (3.51)$$

where, according to 1.4.1, \mathcal{C} comes with a coring structure over A , (C, Δ_C, e_C) and \mathcal{D} is an A -coring (D, Δ_D, e_D) . Also l and r are A -coring morphisms, i.e. morphisms of comonoids in ${}_A \mathcal{M}_A$. Finally, $\theta : D^l \longrightarrow {}^r C$ is an isomorphism of D - C -comodules.

The definition given above is the same as an adjunction $l \dashv r$ with domain (C, A) and codomain (D, A) , in $\mathbf{IntCat}(\mathbf{Mod}_R^{op})$, where the bicomodule property is equivalent to that of the binaturality.

The coring twisting datum in (3.51), through the adjunction $l \dashv r$, induces a Kleisli adjunction from (C, A) to $(A_{rl} \otimes_A C, A)$, which in turn, induces an A -coring twisting datum as follows

$$(\mathcal{C}_\theta \begin{array}{c} \xrightarrow{\bar{l}} \\ \xleftarrow{\bar{r}} \end{array} \mathcal{C}, \bar{\theta}) \quad . \quad (3.52)$$

where $\bar{l} = (e_D \cdot \theta^{-1} \otimes_A C) \cdot \Delta_C$ and $\bar{r} = \theta \cdot r$ and $\bar{\theta} = 1_C$. The A -bimodule \mathcal{C}_θ is the coring C , but with twisted structure given by

$$\Delta_C^\theta = (\theta \cdot r \otimes_A C) \cdot \Delta_C \quad , \quad (3.53a)$$

$$e_C^\theta = e_D \cdot \theta^{-1} \quad . \quad (3.53b)$$

In the same way, the coring twisted datum in (3.51), through the adjunction $l \dashv r$, induces a coKleisli adjunction from $(D \otimes_A {}_l r A, A)$ to (D, A) , which in turn, induces an A -coring twisting datum as follows

$$(\mathcal{D} \begin{array}{c} \xrightarrow{l'} \\ \xleftarrow{r'} \end{array} \mathcal{D}^\theta, \theta') \quad .$$

where the coring \mathcal{D}^θ is the coring D with the following twisted structure

$$\Delta_D^\theta = (D \otimes_A \theta^{-1} \cdot l) \cdot \Delta_D \quad , \quad (3.54a)$$

$$e_D^\theta = e_C \cdot \theta \quad . \quad (3.54b)$$

The process of inducing twisted coring structures does not go indefinitely since, as explained in [20], the completion of a 2-category for Kleisli objects consists of only one step, hence this process of inducing twisted structures has to stop after one step. In particular, $\mathcal{C}_\theta = \mathcal{C}$ and $(\mathcal{C}_\theta)^{\bar{\theta}} = \mathcal{C}$.

Chapter 4

Morita Contexts and Double Adjunctions

This chapter is based on [11]. In this chapter, the category of *double adjunctions* for a pair of categories is defined, afterwards the category of *Morita contexts* on a pair of categories is defined. Altogether it will be the theoretical basis for the development of an adjunction between these two categories, given a resemblance to the interaction between single adjunctions and monads. This resemblance will finally lead us to a Beck-type theorem at the end of this chapter.

4.1 Double Adjunctions

In this section, the category of double adjunctions is given, this will be the first and one of the most important definitions for the whole of the chapter. Without further ado, let \mathcal{A} and \mathcal{B} be two categories, the objects of the category of double adjunctions over \mathcal{A} and \mathcal{B} , $\mathbf{Adj}(\mathcal{A}, \mathcal{B})$, are defined as follows

$$\begin{array}{ccc}
 \mathcal{A} & \begin{array}{l} \xleftarrow{R_a} \\ \xrightarrow{L_a} \end{array} & \mathcal{L} \\
 & \begin{array}{l} \xrightarrow{R_b} \\ \xleftarrow{L_b} \end{array} & \\
 \mathcal{B} & &
 \end{array} , \tag{4.1}$$

where the L 's and R 's are adjunctions, the shorthand notation $(\mathcal{L}, L_a \dashv R_a, L_b \dashv R_b)$ will be used quite frequently. The morphisms in this category are $\bar{F} : (\mathcal{L}, L_a \dashv R_a, L_b \dashv R_b) \longrightarrow (\mathcal{L}', L'_a \dashv R'_a, L'_b \dashv R'_b)$, where $F : \mathcal{L}' \longrightarrow \mathcal{L}$ is a functor such that the following diagram commutes

$$\begin{array}{ccc}
 & \mathcal{A} & \\
 R'_a \nearrow & & \nwarrow R_a \\
 \mathcal{L}' & \xrightarrow{F} & \mathcal{L} \\
 R'_b \searrow & & \swarrow R_b \\
 & \mathcal{B} &
 \end{array} . \tag{4.2}$$

The respective diagram for the L 's is not required to commute, but there exist natural transformations

$$\alpha = (\varepsilon^a F L'_a) \circ (L_a \eta'^a) : L_a \longrightarrow F L'_a , \tag{4.3a}$$

$$\beta = (\varepsilon^b F L'_b) \circ (L_b \eta'^b) : L_b \longrightarrow F L'_b , \tag{4.3b}$$

such that the following properties hold

$$(R_a \alpha) \circ \eta^a = \eta'^a \quad , \quad \varepsilon^a F = (F \varepsilon'^a) \circ (\alpha R'_a) , \tag{4.4a}$$

$$(R_b \beta) \circ \eta^b = \eta'^b \quad , \quad \varepsilon^b F = (F \varepsilon'^b) \circ (\beta R'_b) . \tag{4.4b}$$

4.2 Morita Contexts

Let \mathcal{A} and \mathcal{B} be categories, then the objects of the category of *Morita contexts*, denoted by $\mathbf{Mor}(\mathcal{A}, \mathcal{B})$ are defined as follows

$$(A, B, T, \widehat{T}, ev, \widehat{ev}) , \tag{4.5}$$

which is a short notation for monads (A, μ^A, η^A) and (B, μ^B, η^B) over \mathcal{A} and \mathcal{B} , respectively. The functors T and \widehat{T} , on the other hand, deserve a detailed look. The functor $T : \mathcal{B} \longrightarrow \mathcal{A}$ is called an *A-B bialgebra functor* provided the natural transformations $\lambda : AT \longrightarrow T$ and $\rho : TB \longrightarrow T$ fulfill the following requirements

$$\begin{array}{ccc}
 AAT & \xrightarrow{\mu^{AT}} & AT \\
 \downarrow A\lambda & & \downarrow \lambda \\
 AT & \xrightarrow{\lambda} & T
 \end{array}
 , \quad
 \begin{array}{ccc}
 T & \xrightarrow{\eta^{AT}} & AT \\
 \searrow = & & \downarrow \lambda \\
 & & T
 \end{array}
 , \tag{4.6}$$

for $\lambda : AT \longrightarrow T$, and for $\rho : TB \longrightarrow B$

$$\begin{array}{ccc}
 TB & \xleftarrow{T\mu^B} & TBB \\
 \downarrow \rho & & \downarrow \rho^B \\
 T & \xleftarrow{\rho} & TB
 \end{array}
 , \quad
 \begin{array}{ccc}
 TB & \xleftarrow{T\eta^B} & T \\
 \downarrow \rho & \swarrow = & \\
 T & &
 \end{array}
 . \tag{4.7}$$

Last but not least, the compatibility condition

$$\begin{array}{ccc}
 ATB & \xrightarrow{\lambda^B} & TB \\
 \downarrow A\rho & & \downarrow \rho \\
 AT & \xrightarrow{\lambda} & T
 \end{array} \tag{4.8}$$

is also required.

A natural transformation $\alpha : T \longrightarrow T'$, such that the following diagrams commute

$$\begin{array}{ccc}
AT & \xrightarrow{A\alpha} & AT' \\
\downarrow \lambda & & \downarrow \lambda' \\
T & \xrightarrow{\alpha} & T'
\end{array}, \quad
\begin{array}{ccc}
TB & \xrightarrow{\alpha B} & T'B \\
\downarrow \rho & & \downarrow \rho' \\
T & \xrightarrow{\alpha} & T'
\end{array}, \quad (4.9)$$

is called an A - B *bialgebra morphism*. These definitions are the ingredients of a new category called ${}_A\mathcal{F}_B$.

In a similar fashion, the functor $\widehat{T} : \mathcal{A} \rightarrow \mathcal{B}$ has to be a B - A bialgebra functor through the natural transformations $\widehat{\lambda} : B\widehat{T} \rightarrow \widehat{T}$ and $\widehat{\rho} : \widehat{T}A \rightarrow \widehat{T}$.

Finally, the natural transformation $ev : T\widehat{T} \rightarrow A$ has to be an A - A bialgebra morphism and $\widehat{ev} : \widehat{T}T \rightarrow B$ a B - B bialgebra morphism along with the requirement that the following diagrams

$$\begin{array}{ccc}
T\widehat{T}T & \xrightarrow{T\widehat{ev}} & TB \\
\downarrow evT & & \downarrow \rho \\
AT & \xrightarrow{\lambda} & T
\end{array}, \quad
\begin{array}{ccc}
TB\widehat{T} & \xrightarrow{T\widehat{\lambda}} & T\widehat{T} \\
\downarrow \rho\widehat{T} & & \downarrow ev \\
T\widehat{T} & \xrightarrow{ev} & A
\end{array}, \quad (4.10)$$

$$\begin{array}{ccc}
\widehat{T}T\widehat{T} & \xrightarrow{\widehat{T}ev} & \widehat{T}A \\
\downarrow \widehat{ev}\widehat{T} & & \downarrow \widehat{\rho} \\
B\widehat{T} & \xrightarrow{\widehat{\lambda}} & \widehat{T}
\end{array}, \quad
\begin{array}{ccc}
\widehat{T}AT & \xrightarrow{\widehat{T}\lambda} & \widehat{T}T \\
\downarrow \widehat{\rho}T & & \downarrow \widehat{ev} \\
\widehat{T}T & \xrightarrow{\widehat{ev}} & B
\end{array}, \quad (4.11)$$

commute. The morphisms for this category are

$$\varphi = (\varphi_1, \varphi_2, \varphi_3, \varphi_4) : (A, B, T, \widehat{T}, ev, \widehat{ev}) \longrightarrow (A', B', T', \widehat{T}', ev', \widehat{ev}') , \quad (4.12)$$

where the definition of each of the φ 's goes as follows, $\varphi_1 : A \longrightarrow A'$ is a *morphism of monads*, that is to say, it is a natural transformation such that the following diagrams commute

$$\begin{array}{ccc} AA & \xrightarrow{\varphi_1 * \varphi_1} & A'A' \\ \mu^A \downarrow & & \downarrow \mu^{A'} \\ A & \xrightarrow{\varphi_1} & A' \end{array} , \quad \begin{array}{ccc} & 1_A & \\ \eta^A \swarrow & & \searrow \eta^{A'} \\ A & \xrightarrow{\varphi_1} & A' \end{array} , \quad (4.13)$$

where $\varphi_1 * \varphi_1$ is the Godement product as in (1.23). In the same way, $\varphi_2 : B \longrightarrow B'$ is a morphism of monads over \mathcal{B} .

Remark 4.2.1. A morphism of monads $\varphi : (F, \mu^F, \eta^F) \longrightarrow (F', \mu^{F'}, \eta^{F'})$ over the category \mathcal{C} , corresponds to the 1-cell $(1_{\mathcal{C}}, \varphi)$ in the 2-category $\mathbf{Mnd}(\mathbf{2Cat})$, see (2.18).

The natural transformation $\varphi_3 : T \longrightarrow T'$ has to be a morphism $\varphi_3 : T \longrightarrow \varphi_1 T' \varphi_2$ in ${}_A \mathcal{F}_B$, *i.e.* the following diagrams commute

$$\begin{array}{ccc} AT & \xrightarrow{A\varphi_3} & AT' \\ \lambda \downarrow & & \downarrow \varphi_1 T' \\ T & \xrightarrow{\varphi_3} & T' \end{array} , \quad \begin{array}{ccc} TB & \xrightarrow{\varphi_3 B} & T'B \\ \rho \downarrow & & \downarrow T' \varphi_2 \\ T & \xrightarrow{\varphi_3} & T' \end{array} . \quad (4.14)$$

In a similar way, $\varphi_4 : \widehat{T} \longrightarrow \widehat{T}'$ has to be a morphism $\varphi_4 : \widehat{T} \longrightarrow \varphi_2 \widehat{T}' \varphi_1$ in ${}_B \mathcal{F}_A$. The final requirement for the morphism $\varphi = (\varphi_1, \varphi_2, \varphi_3, \varphi_4)$ is the commutativity of the following diagrams

$$\begin{array}{ccc}
T\hat{T} & \xrightarrow{\varphi_3*\varphi_4} & T'\hat{T}' \\
\downarrow ev & & \downarrow ev' \\
A & \xrightarrow{\varphi_1} & A'
\end{array}
, \quad
\begin{array}{ccc}
\hat{T}T & \xrightarrow{\varphi_4*\varphi_3} & \hat{T}'T' \\
\downarrow \hat{ev} & & \downarrow \hat{ev}' \\
B & \xrightarrow{\varphi_2} & B'
\end{array}
. \quad (4.15)$$

4.3 Adjunction between $\mathbf{Mor}(\mathcal{A}, \mathcal{B})$ and $\mathbf{Adj}(\mathcal{A}, \mathcal{B})$

4.3.1 The Left Adjoint

In order to construct the left adjoint, a shared codomain category for the *a posteriori* double adjunction, corresponding to any given Morita context, has to be constructed. Due to the fact that the construction of this codomain category is lengthy, it is to be done on its own. Let $(A, B, T, \hat{T}, ev, \hat{ev})$ be a Morita context. The definition of the *Eilenberg-Moore category for a Morita context*

$$(\mathcal{A}, \mathcal{B})^{(A, B)}, \quad (4.16)$$

goes as follows. The objects of this category, the so-called *Eilenberg-Moore algebras* (for a Morita context), are

$$((M, {}^A\chi_M), (N, {}^B\chi_N), \bar{v}, \bar{w}), \quad (4.17)$$

such that

- i) $(M, {}^A\chi_M)$ is an object in \mathcal{A}^A ,
- ii) $(N, {}^B\chi_N)$ is an object in \mathcal{B}^B ,
- iii) $\bar{v} : TN \longrightarrow M$ is a morphism in \mathcal{A}^A ,
- iv) $\bar{w} : \hat{T}M \longrightarrow N$ is a morphism in \mathcal{B}^B ,

and they fulfill the following requirements:

$$\begin{array}{ccc}
T\widehat{T}M & \xrightarrow{evM} & AM \\
\downarrow Tw & & \downarrow A_{\chi_M} \\
TN & \xrightarrow{v} & M
\end{array}
, \quad
\begin{array}{ccc}
TBN & \xrightarrow{T^B\chi_N} & TN \\
\downarrow \rho_N & & \downarrow v \\
TN & \xrightarrow{v} & M
\end{array}
, \quad (4.18)$$

and

$$\begin{array}{ccc}
\widehat{T}TN & \xrightarrow{\widehat{ev}N} & BN \\
\downarrow \widehat{T}v & & \downarrow B_{\chi_N} \\
\widehat{T}M & \xrightarrow{w} & N
\end{array}
, \quad
\begin{array}{ccc}
\widehat{T}AM & \xrightarrow{\widehat{T}^A\chi_M} & \widehat{T}M \\
\downarrow \widehat{\rho}M & & \downarrow w \\
\widehat{T}M & \xrightarrow{w} & N
\end{array}
. \quad (4.19)$$

The bar notation over morphisms will be omitted whenever is possible in order to avoid complicated expressions.

The morphisms for the category of Eilenberg-Moore algebras are described as follows:

$$(\bar{f}, \bar{g}) : ((M, {}^A\chi_M), (N, {}^B\chi_N), \bar{v}, \bar{w}) \longrightarrow ((M', {}^A\chi_{M'}), (N', {}^B\chi_{N'}), \bar{v}', \bar{w}') , \quad (4.20)$$

such that

i) $\bar{f} : (M, {}^A\chi_M) \longrightarrow (M', {}^A\chi_{M'})$ is a morphism in \mathcal{A}^A ,

ii) $\bar{g} : (N, {}^B\chi_N) \longrightarrow (N', {}^B\chi_{N'})$ is a morphism in \mathcal{B}^B ,

and also they fulfill the following requirements:

$$\begin{array}{ccc}
TN & \xrightarrow{Tg} & TN' \\
\downarrow v & & \downarrow v' \\
M & \xrightarrow{f} & M'
\end{array}
, \quad
\begin{array}{ccc}
\widehat{T}M & \xrightarrow{\widehat{T}f} & \widehat{T}M' \\
\downarrow w & & \downarrow w' \\
N & \xrightarrow{g} & N'
\end{array}
. \quad (4.21)$$

The short notation (M, N) for an object in $(\mathcal{A}, \mathcal{B})^{(A, B)}$ proves to be helpful. The identity morphism for an object (M, N) in $(\mathcal{A}, \mathcal{B})^{(A, B)}$ is $1_{(M, N)} = (1_M, 1_N)$, as expected. The composition of morphisms $(\overline{f'}, \overline{g'}) \cdot (\overline{f}, \overline{g})$ is done componentwisely, *i.e.* $(f' \cdot f, g' \cdot g)$.

Once the Eilenberg-Moore category for a Morita context has been described, the definition of the left adjoint functor

$$\Gamma : \mathbf{Mor}(\mathcal{A}, \mathcal{B}) \longrightarrow \mathbf{Adj}(\mathcal{A}, \mathcal{B}) , \quad (4.22)$$

can be given without further ado. Over objects, it is described as

$$\Gamma(A, B, T, \widehat{T}, ev, \widehat{ev}) = ((\mathcal{A}, \mathcal{B})^{(A, B)}, D^a \dashv U^a, D^b \dashv U^b) . \quad (4.23)$$

This object can be represented as the following diagram

$$\begin{array}{ccc}
\mathcal{A} & & \\
\swarrow U^a & & \searrow D^a \\
& & (\mathcal{A}, \mathcal{B})^{(A, B)} \\
\swarrow U^b & & \searrow D^b \\
\mathcal{B} & &
\end{array}
.$$

The description of the adjunctions goes as follows. For the first one, $D^a \dashv U^a$, D^a is defined over objects, X in \mathcal{A} , as

$$D^a(X) = ((AX, \mu^A X), (\widehat{T}X, \widehat{\lambda}X), evX, \widehat{\rho}X) , \quad (4.24)$$

and over morphisms $h : X \longrightarrow X'$ in \mathcal{A} , as

$$D^a(h) = (Ah, \widehat{T}h) : (AX, \widehat{T}X) \longrightarrow (AX', \widehat{T}X') . \quad (4.25)$$

At this point, the following proposition is needed.

Proposition 4.3.1.1. *The functor $D^a : \mathcal{A} \longrightarrow (\mathcal{A}, \mathcal{B})^{(A,B)}$ is well-defined.*

Proof:

First, it has to be checked that $((AX, \mu^A X), (\widehat{T}X, \widehat{\lambda}X), evX, \widehat{\rho}X)$ is an Eilenberg-Moore algebra. That $(AX, \mu^A X)$ is in \mathcal{A}^A is clear since this part of the functor is the free algebra functor for the monad A as defined in the proof of Proposition 2.1.2. That $(\widehat{T}X, \widehat{\lambda}X)$ is an object in \mathcal{B}^B can be deduced from the property of \widehat{T} being a left B -algebra functor applied to X . That $evX : T\widehat{T}X \longrightarrow AX$ is a morphism in \mathcal{A}^A is deduced from the fact that ev is a left A -algebra morphism evaluated in X . That $\widehat{\rho}X : \widehat{T}AX \longrightarrow \widehat{T}X$ is a morphism in \mathcal{B}^B follows from the compatibility condition imposed on the B - A -bialgebra functor \widehat{T} evaluated on X . The diagrams in (4.18) are translated to the following ones

$$\begin{array}{ccc} T\widehat{T}AX & \xrightarrow{evAX} & AAX \\ \downarrow T\widehat{\rho}X & & \downarrow \mu^A X \\ T\widehat{T}X & \xrightarrow{evX} & AX \end{array} , \quad \begin{array}{ccc} TB\widehat{T}X & \xrightarrow{T\widehat{\lambda}X} & T\widehat{T}X \\ \downarrow \widehat{\rho}TX & & \downarrow evX \\ T\widehat{T}X & \xrightarrow{evX} & AX \end{array} .$$

Both these diagrams commute, the first one because ev is, in particular, a right A -algebra morphism evaluated at X , and the second one because this diagram is part of the requirements for a Morita context, namely the second diagram in (4.10) evaluated at X . The commutativity of the remaining diagrams in (4.19), can be proved in a similar way. The first one commutes because it corresponds to the first commutative diagram in (4.11), the second one commutes because it corresponds to the fact that \widehat{T} is a right A -algebra functor.

Second, we have to check that $(Ah, \widehat{T}h) : (AX, \widehat{T}X) \longrightarrow (AX', \widehat{T}X')$ is a morphism of Eilenberg-Moore algebras. That $Ah : AX \longrightarrow AX'$ is a morphism in \mathcal{A}^A follows from the naturality of μ^A , and that $\widehat{T}h : \widehat{T}X \longrightarrow \widehat{T}X'$ is a morphism in \mathcal{B}^B follows from the naturality of $\widehat{\lambda}$. On the other hand, the diagrams in (4.21) are translated to the following ones

$$\begin{array}{ccc}
T\widehat{T}X & \xrightarrow{T\widehat{T}h} & T\widehat{T}X' \\
\downarrow ev_X & & \downarrow ev_{X'} \\
AX & \xrightarrow{Ah} & AX'
\end{array}
, \quad
\begin{array}{ccc}
\widehat{T}AX & \xrightarrow{\widehat{T}Ah} & \widehat{T}AX' \\
\downarrow \widehat{\rho}_X & & \downarrow \widehat{\rho}_{X'} \\
\widehat{T}X & \xrightarrow{\widehat{T}h} & \widehat{T}X'
\end{array}
.$$

These last diagrams commute because of the naturality of ev over h and because of the naturality of $\widehat{\rho}$ over h , respectively. \square

The functoriality of D^a follows componentwisely from the functoriality of A and \widehat{T} . This completes the definition of D^a .

On the other hand, the definition of U^a goes as follows. Let (M, N) be an object in $(\mathcal{A}, \mathcal{B})^{(A, B)}$, then

$$U^a((M, {}^A\chi_M), (N, {}^B\chi_N), \bar{v}, \bar{w}) = M , \quad (4.26)$$

and for morphisms, $(\bar{f}, \bar{g}) : (M, N) \longrightarrow (M', N')$,

$$U^a(\bar{f}, \bar{g}) = f , \quad (4.27)$$

where $f : M \longrightarrow M'$ is a morphism in \mathcal{A} . The proof of U^a being well-defined and a functor, is clear.

Proposition 4.3.1.2. D^a and U^a form an adjunction, $D^a \dashv U^a$.

Proof:

The unit of the adjunction

$$\eta^{U^a D^a} : 1_{\mathcal{A}} \longrightarrow U^a D^a , \quad (4.28)$$

is defined on objects as

$$\eta^{U^a D^a} X : X \xrightarrow{\eta^{AX}} AX . \quad (4.29)$$

The counit of the adjunction

$$\varepsilon^{D^a U^a} : D^a U^a \longrightarrow 1_{(\mathcal{A}, \mathcal{B})^{(A, B)}} , \quad (4.30)$$

is defined on objects as

$$\varepsilon^{D^a U^a}(M, N) : (AM, \widehat{T}M) \xrightarrow{(\overline{{}^A\chi_M}, \overline{w})} (M, N) . \quad (4.31)$$

Note that $(AM, \widehat{T}M)$ stands, as a short notation, for $((AM, {}^A\chi_M), (\widehat{T}M, \lambda\widehat{T}M), evM, \widehat{\rho}M)$. That the morphism $(\overline{{}^A\chi_M}, \overline{w}) : (AM, \widehat{T}M) \longrightarrow (M, N)$ is a morphism in $(\mathcal{A}, \mathcal{B})^{(A, B)}$ is proved as follows. The morphism $\overline{{}^A\chi_M} : AM \longrightarrow M$ is a morphism in \mathcal{A}^A since this is the definition of the counit for usual Eilenberg-Moore adjunction, corresponding to the monad A , (2.14). Second, $\overline{w} : \widehat{T}M \longrightarrow N$ is a morphism in \mathcal{B}^B , by hypothesis. Hence, there remains only to prove the commutativity of the diagrams in (4.21), but once they are translated they are nothing but the first diagram in (4.18) and the second diagram in (4.19), respectively, whose commutativity holds by hypothesis.

Now that the unit and the counit have been defined, let us proceed to prove the triangular identities for the adjunction. The first of them, the one associated to the left adjoint D^a , is

$$\varepsilon^{D^a U^a} D^a \circ D^a \eta^{U^a D^a} = 1_{D^a} .$$

In order to prove such a statement, let X be an object in \mathcal{A} , then the composition can be broken down to

$$D^a \eta^{U^a D^a} X = D^a \eta^A X = (A\eta^A X, \widehat{T}\eta^A X) ,$$

and

$$\varepsilon^{D^a U^a} D^a X = \varepsilon^{D^a U^a}((AX, \mu^A X), (\widehat{T}X, \widehat{\lambda}X), evX, \widehat{\rho}X) = (\mu^A X, \widehat{\rho}X) ,$$

and finally $1_{D^a X} = (1_{AX}, 1_{\widehat{T}X})$. The composition now looks like

$$(\mu^A X, \widehat{\rho}X) \cdot (A\eta^A X, \widehat{T}\eta^A X) = (\mu^A X \cdot A\eta^A X, \widehat{\rho}X \cdot \widehat{T}\eta^A X) = (1_{AX}, 1_{\widehat{T}X}) ,$$

where the equality holds, first because of the unitality of the monad A , and second because of \widehat{T} being a right A -algebra functor.

The triangular identity associated to the right adjoint U^a is

$$U^a \varepsilon^{D^a U^a} \circ \eta^{U^a D^a} U^a = 1_{U^a} .$$

Let (M, N) be an object in \mathcal{A}^A , then the composition can be broken down to

$$\eta^{U^a D^a} U^a(M, N) = \eta^{U^a D^a} M = \eta^A M ,$$

and

$$U^a \varepsilon^{D^a U^a}(M, N) = U^a({}^A\bar{\chi}_M, \bar{w}) = {}^A\chi_M ,$$

and also $1_{U^a}(M, N) = 1_{U^a(M, N)} = 1_M$. All together it looks like,

$${}^A\chi_M \cdot \eta^A M = 1_M ,$$

which holds since $(M, {}^A\chi_M)$ is in \mathcal{A}^A . □

The next proposition is stated without any proof since it is similar to the one just given.

Proposition 4.3.1.3. *D^b and U^b form an adjunction, $D^b \dashv U^b$.*

The unit and counit of the adjunction $D^b \dashv U^b$ are given for the sake of completeness and referencing:

$$\eta^{U^b D^b} Y = \eta^B Y : Y \longrightarrow BY , \tag{4.32a}$$

$$\varepsilon^{D^b U^b}(M, N) = (\bar{v}, {}^B\bar{\chi}_N) : (TN, BN) \longrightarrow (M, N) . \tag{4.32b}$$

The functor $\Gamma : \mathbf{Mor}(\mathcal{A}, \mathcal{B}) \longrightarrow \mathbf{Adj}(\mathcal{A}, \mathcal{B})$ is defined over morphisms $\varphi : (A, B, T, \widehat{T}) \longrightarrow (A', B', T', \widehat{T}')$ as follows. The image of the morphism φ under the functor Γ has to be a functor such that $\Gamma(\varphi) : (\mathcal{A}, \mathcal{B})^{(A', B')} \longrightarrow (\mathcal{A}, \mathcal{B})^{(A, B)}$. In order to construct such a functor, let us state the following proposition.

Proposition 4.3.1.4. *Let $\varphi : (\mathcal{C}, F, \mu^F, \eta^F) \longrightarrow (\mathcal{C}, F', \mu^{F'}, \eta^{F'})$ be a morphism of monads, then there exists a functor ${}_\varphi H : \mathcal{C}^{F'} \longrightarrow \mathcal{C}^F$ between their Eilenberg-Moore categories of algebras.*

Proof:(Sketch)

Define ${}_\varphi H$ over objects $(N, {}^{F'}\chi_N)$ in $\mathcal{C}^{F'}$ as $(N, {}^{F'}\chi_N \cdot \varphi_N)$. Define ${}_\varphi H$ over morphisms $\bar{h} : (N, {}^{F'}\chi_N) \longrightarrow (N', {}^{F'}\chi_{N'})$ as

$${}_\varphi H(\bar{h}) = \bar{h} : (N, {}^{F'}\chi_N \cdot \varphi_N) \longrightarrow (N', {}^{F'}\chi_{N'} \cdot \varphi_{N'}) . \tag{4.33}$$

□

Resuming with the construction of the functor, $\Gamma(\varphi)$ is defined over an object $((P, {}^A\chi_P), (Q, {}^B\chi_Q), r, s)$ in $(\mathcal{A}, \mathcal{B})^{(A', B')}$ as

$$\Gamma(\varphi)(P, Q) = ((P, {}^A\chi_P \cdot \varphi_1 P), (Q, {}^B\chi_Q \cdot \varphi_2 Q), r \cdot \varphi_3 Q, s \cdot \varphi_4 P) .$$

On a morphism $(\bar{p}, \bar{q}) : ((P, {}^A\chi_P), (Q, {}^B\chi_Q), r, s) \longrightarrow ((P', {}^A\chi_{P'}), (Q', {}^B\chi_{Q'}), r', s')$ it is defined as

$$\Gamma(\varphi)(\bar{p}, \bar{q}) = (\bar{p}, \bar{q}) ,$$

where $(\bar{p}, \bar{q}) : ((P, {}^A\chi_P \cdot \varphi_1 P), (Q, {}^B\chi_Q \cdot \varphi_2 Q), r \cdot \varphi_3 Q, s \cdot \varphi_4 P) \longrightarrow ((P', {}^A\chi_{P'} \cdot \varphi_1 P'), (Q', {}^B\chi_{Q'} \cdot \varphi_2 Q'), r' \cdot \varphi_3 Q', s' \cdot \varphi_4 P')$ is a morphism in $(\mathcal{A}, \mathcal{B})^{(A, B)}$. The notation $\bar{\leftarrow}$ means, for example, that the underlying morphism $p : P \longrightarrow P'$ remains the same but not the requirements over it, *i.e.* the bar notation corresponds to p fulfilling the requirements for the Morita context $(A', B', T', \widehat{T}', ev', \widehat{ev}')$ while the notation \leftarrow corresponds to the requirements for the Morita context $(A, B, T, \widehat{T}, ev, \widehat{ev})$ instead. Without further ado, let state the following

Proposition 4.3.1.5. $\Gamma(\varphi)$ is well-defined and it is a functor.

Proof:

First, on objects, we need to prove that $((P, {}^A\chi_P \cdot \varphi_1 P), (Q, {}^B\chi_Q \cdot \varphi_2 Q), r \cdot \varphi_3 Q, s \cdot \varphi_4 P)$ is an object in $(\mathcal{A}, \mathcal{B})^{(A, B)}$.

The object $(P, {}^A\chi_P \cdot \varphi_1 P)$ is in \mathcal{A}^A because it is the image of the functor $\varphi_1 H$, see Proposition 4.3.1.4. $(Q, {}^B\chi_Q \cdot \varphi_2 Q)$ is an object in \mathcal{B}^B because is the image under the functor $\varphi_2 H$. The next thing to get through is that $r \cdot \varphi_3 Q : ATQ \longrightarrow AP$ is a morphism in \mathcal{A}^A . This requirement is translated to the outer most diagram in

$$\begin{array}{ccccc}
 ATQ & \xrightarrow{A\varphi_3 Q} & AT'Q & \xrightarrow{Ar} & AP \\
 \downarrow \lambda Q & & \downarrow \varphi_1 T'Q & \text{(ii)} & \downarrow \varphi_1 P \\
 & & A'T'Q & \xrightarrow{A'r} & A'P \\
 & \text{(i)} & \downarrow \lambda' Q & \text{(iii)} & \downarrow A'\chi_P \\
 TQ & \xrightarrow{\varphi_3 Q} & T'Q & \xrightarrow{r} & P
 \end{array} .$$

This diagram was broken down already in order to help to write the argument for its commutativity.

The diagram in (i) commutes because $\varphi_3 : T \rightarrow {}_{\varphi_1}T$ is a morphism in ${}_A\mathcal{F}$, in turn, (ii) commutes because of the naturality of φ_1 over r , and finally, (iii) commutes because $r : T'Q \rightarrow P$ is in $\mathcal{A}^{A'}$. That $s \cdot \varphi_4 P : \widehat{TP} \rightarrow Q$ is a morphism in \mathcal{B}^B , is proved similarly.

It remains to show the commutativity of the diagrams in (4.18) and (4.19). Starting with the first diagram in (4.18), this is translated to the following one

$$\begin{array}{ccccc}
 T\widehat{TP} & \xrightarrow{\quad evP \quad} & AP & & \\
 \downarrow T\varphi_4P & & \downarrow \varphi_1P & & \\
 T\widehat{T'P} & \xrightarrow{\varphi_3\widehat{T'P}} & T'\widehat{T'P} & \xrightarrow{ev'P} & A'P \\
 \downarrow Ts & (iii) & \downarrow T's & (ii) & \downarrow A'\chi_P \\
 TQ & \xrightarrow{\varphi_3Q} & T'Q & \xrightarrow{r} & P
 \end{array} ,$$

which commutes because in (i) the expression $\varphi_3\widehat{T'P} \cdot T\varphi_4P$ is the definition of $(\varphi_3 * \varphi_4)(P)$, then this diagram corresponds to the first one in (4.15) for the requirements of a morphism of Morita context. In turn, (ii) commutes because this diagram is the first requirement in (4.18) for the Eilenberg-Moore algebra (P, Q) . Finally, (iii) commutes because of the naturality of φ_3 over s .

Resuming with the second diagram in (4.18), this can be translated to the following one

$$\begin{array}{ccccc}
 TBQ & \xrightarrow{T\varphi_2Q} & TB'Q & \xrightarrow{T^{B'}\chi_Q} & TQ \\
 \downarrow \rho_Q & & \downarrow \varphi_3B'Q & (ii) & \downarrow \varphi_3Q \\
 & (i) & T'B'Q & \xrightarrow{T'^{B'}\chi_Q} & T'Q \\
 & & \downarrow \rho'Q & (iii) & \downarrow r \\
 TQ & \xrightarrow{\varphi_3Q} & T'Q & \xrightarrow{r} & P
 \end{array} ,$$

which commutes because the inner diagrams commute. The one corresponding to (i) commutes because the morphism $\varphi_3B'Q \cdot T\varphi_2Q$ is equal, through the Godement equality of $(\varphi_3 * \varphi_2)(Q)$, (1.23), to $T'\varphi_2Q \cdot \varphi_3BQ$; if this morphism is substituted back in (i), it gives the requirement (4.14) for a morphism of Morita contexts. In turn, (ii) commutes because of the naturality of φ_3 over ${}^{B'}\chi_Q$ and finally, (iii) commutes because it is the second requirement in (4.18) for the Eilenberg-Moore algebra (P, Q) .

The requirements for the diagrams in (4.19) are sorted out similarly.

The fact that the functor $\Gamma(\varphi)$ is well-defined on morphisms is proved as follows. That $\overleftarrow{p}: (P, {}^A\chi_P \cdot \varphi_1 P) \longrightarrow (P', {}^A\chi_{P'} \cdot \varphi_1 P')$ is a morphism in \mathcal{A}^A follows from the properties of the functor $\varphi_1 H$. Likewise, $\overleftarrow{q}: (Q, {}^B\chi_Q \cdot \varphi_2 Q) \longrightarrow (Q', {}^B\chi_{Q'} \cdot \varphi_2 Q')$ is a morphism in \mathcal{B}^B . Furthermore, take the first diagram in (4.21) and translate it to

$$\begin{array}{ccc}
 TQ & \xrightarrow{Tq} & TQ' \\
 \varphi_3 Q \downarrow & (i) & \downarrow \varphi_3 Q' \\
 T'Q & \xrightarrow{T'q} & T'Q' \\
 r \downarrow & (ii) & \downarrow r' \\
 P & \xrightarrow{p} & P'
 \end{array} .$$

The diagram (i) commutes because of the naturality of φ_3 over q , and (ii) commutes because $(\overleftarrow{p}, \overleftarrow{q})$ is a morphism of Eilenberg-Moore algebras for the Morita context $(A', B', T', \widehat{T}')$. The second diagram in (4.21) commutes by similar arguments as the previous one. Therefore, $(\overleftarrow{p}, \overleftarrow{q})$ is a morphism of Eilenberg-Moore algebras for the Morita context $(A, B, T, \widehat{T}, ev, \widehat{ev})$.

On the other hand, it is clear that $\Gamma(\varphi)(1_{(P,Q)}) = \Gamma(\varphi)(\overline{1}_P, \overline{1}_Q) = (\overline{1}_P, \overline{1}_Q) = 1_{\Gamma(\varphi)(P,Q)}$. Also, let $(\overleftarrow{p'}, \overleftarrow{q'}) \cdot (\overleftarrow{p}, \overleftarrow{q})$ be a composition of morphisms, therefore $\Gamma(\varphi)(\overleftarrow{p'} \cdot \overleftarrow{p}, \overleftarrow{q'} \cdot \overleftarrow{q}) = (\overleftarrow{p'} \cdot \overleftarrow{p}, \overleftarrow{q'} \cdot \overleftarrow{q}) = (\overleftarrow{p'}, \overleftarrow{q'}) \cdot (\overleftarrow{p}, \overleftarrow{q}) = \Gamma(\varphi)(\overleftarrow{p'}, \overleftarrow{q'}) \cdot \Gamma(\varphi)(\overleftarrow{p}, \overleftarrow{q})$. This completes the proof of the proposition. \square

It remains to check the interaction of the functor $\Gamma(\varphi)$ with the right adjoints. In order to do so, let (P, Q) be an object in $(\mathcal{A}, \mathcal{B})^{(A', B')}$, then

$$U^a \cdot \Gamma(\varphi)(P, Q) = U^a(P, Q) = P = U'^a(P, Q) ,$$

therefore $U^a \cdot \Gamma(\varphi) = U'^a$, and the same is true about the U^b 's. This finishes the proof that Γ is well-defined on morphisms. Once this part has been finished, one can proceed to check the functoriality of Γ . Let us start with $\varphi = 1_{(A,B,T,\widehat{T})} = (1_A, 1_B, 1_T, 1_{\widehat{T}})$, then

$$\begin{aligned}
 \Gamma(1_A, 1_B, 1_T, 1_{\widehat{T}})((M, {}^A\chi_M), (N, {}^B\chi_N), v, w) &= ((M, {}^A\chi_M \cdot 1_A M), (N, {}^B\chi_N \cdot 1_B N), v \cdot 1_T N, w \cdot 1_{\widehat{T}} M) \\
 &= ((M, {}^A\chi_M), (N, {}^B\chi_N), v, w) ,
 \end{aligned}$$

which means that $\Gamma(1_{(A,B,T,\widehat{T})}) = 1_{\Gamma(A,B,T,\widehat{T})}$.

Consider the following composite $\varphi' \cdot \varphi$. If Γ is applied to this composite and evaluated at $((P, {}^A\chi_P), (Q, {}^B\chi_Q), r, s)$, then the following calculation can be performed

$$\begin{aligned}
\Gamma(\varphi' \cdot \varphi)(P, Q) &= ((P, {}^{A''}\chi_P \cdot (\varphi'_1 \cdot \varphi_1)P), (Q, {}^{B''}\chi_Q \cdot (\varphi'_2 \cdot \varphi_2)Q), r \cdot (\varphi'_3 \cdot \varphi_3)Q, s \cdot (\varphi'_4 \cdot \varphi_4)P) \\
&= ((P, {}^{A''}\chi_P \cdot \varphi'_1 P \cdot \varphi_1 P), (Q, {}^{B''}\chi_Q \cdot \varphi'_2 Q \cdot \varphi_2 Q), r \cdot \varphi'_3 Q \cdot \varphi_3 Q, s \cdot \varphi'_4 P \cdot \varphi_4 P) \\
&= \Gamma(\varphi)((P, {}^{A''}\chi_P \cdot \varphi'_1 P), (Q, {}^{B''}\chi_Q \cdot \varphi'_2 Q), r \cdot \varphi'_3 Q, s \cdot \varphi'_4 P) \\
&= \Gamma(\varphi)\Gamma(\varphi')(P, Q) .
\end{aligned}$$

Therefore, $\Gamma : \mathbf{Mor}(\mathcal{A}, \mathcal{B}) \longrightarrow \mathbf{Adj}(\mathcal{A}, \mathcal{B})$ is a functor.

4.3.2 The Right Adjoint

This section is devoted to the construction of the right adjoint

$$\Upsilon : \mathbf{Adj}(\mathcal{A}, \mathcal{B}) \longrightarrow \mathbf{Mor}(\mathcal{A}, \mathcal{B}) , \quad (4.34)$$

of Γ .

On objects Υ is defined as

$$\Upsilon(\mathcal{L}, L_a \dashv R_a, L_b \dashv R_b) = (R_a L_a, R_b L_b, R_a L_b, R_b L_a, R_a \varepsilon^b L_a, R_b \varepsilon^a L_b) . \quad (4.35)$$

On morphisms $\overline{F} : (\mathcal{L}, L_a \dashv R_a, L_b \dashv R_b) \longrightarrow (\mathcal{L}', L'_a \dashv R'_a, L'_b \dashv R'_b)$, Υ is defined as

$$\Upsilon(\overline{F}) = (R_a \alpha, R_b \beta, R_a \beta, R_b \alpha) . \quad (4.36)$$

According to this, the following proposition can be stated.

Proposition 4.3.2.1. *The functor $\Upsilon : \mathbf{Adj}(\mathcal{A}, \mathcal{B}) \longrightarrow \mathbf{Mor}(\mathcal{A}, \mathcal{B})$ is well-defined.*

Proof:

†) Over objects.

The monad $(R_a L_a, R_a \varepsilon^a L_a, \eta^a)$ on \mathcal{A} is just the monad induced by an adjunction (2.3), and so is $(R_b L_b, R_b \varepsilon^b L_b, \eta^b)$. That $(R_a L_b, R_a \varepsilon^a L_b, R_a \varepsilon^b L_b)$ is an A - B bialgebra functor is proved as follows. Take the first diagram in (4.6) and represent it with the proposed Morita context, to obtain

$$\begin{array}{ccc}
 R_a L_a R_a L_a R_a L_b & \xrightarrow{R_a \varepsilon^a L_a R_a L_b} & R_a L_a R_a L_b \\
 \downarrow R_a L_a R_a \varepsilon^a L_b & & \downarrow R_a \varepsilon^a L_b \\
 R_a L_a R_a L_b & \xrightarrow{R_a \varepsilon^a L_b} & R_a L_b
 \end{array} ,$$

this diagram commutes because is the result of applying the functor R_a to the naturality of ε^a over $\varepsilon^a L_b$. Now take the second diagram in (4.6) and represent it with the proposed Morita context, to obtain the following diagram

$$\begin{array}{ccc}
 R_a L_b & \xrightarrow{\eta^a R_a L_b} & R_a L_a R_a L_b \\
 \searrow R_a L_b & & \downarrow R_a \varepsilon^a L_b \\
 & & R_a L_b
 \end{array} ,$$

this diagram commutes because is the triangular identity associated to the right adjoint R_a applied to the functor L_b .

These two examples exhaust the arguments required to prove all of the details for the well-definition of the functor Υ over objects. Nevertheless, the arguments are given for the reader to know the procedure of the proof. For example, the two diagrams in (4.7) commute because of the naturality of ε^b over ε^b and the triangular identity associated to the left adjoint L_b , respectively. The compatibility condition (4.8) is fulfilled because of the naturality of ε^a over ε^b . That \widehat{T} is a morphism in ${}_B \mathcal{F}_A$ follows similarly.

On the other hand, the properties required for $ev : T\widehat{T} \longrightarrow A$ and $\widehat{ev} : \widehat{T}T \longrightarrow B$ given by (4.10) follow from the naturality of ε^b over ε^a and the naturality of ε^b over ε^b , respectively. The final requirements in (4.11) follow in a similar way.

†) Over morphisms.

Consider $\varphi_1 = R_a \alpha$. The first requirement in (4.13), translates to the following diagram

$$\begin{array}{ccc}
 R_a L_a R_a L_a & \xrightarrow{R_a L_a R_a \alpha} & R_a L_a R_a F L'_a = R_a L_a R'_a L'_a & \xrightarrow{R_a \alpha R'_a L'_a} & R_a F L'_a R'_a L'_a = R'_a L'_a R'_a L'_a \\
 \downarrow R_a \varepsilon^a L_a & & & & \downarrow R'_a \varepsilon'^a L'_a \\
 R_a L_a & \xrightarrow{R_a \alpha} & R_a F L'_a = R'_a L'_a & &
 \end{array} ,$$

which commutes because of the following calculation

$$\begin{aligned}
R_a \alpha \circ R_a \varepsilon^a L_a &= R_a \varepsilon^a F L'_a \circ R_a L_a R_a \alpha \\
&= R_a (F \varepsilon'^a \circ \alpha R'_a) L'_a \circ R_a L_a R_a \alpha \\
&= R_a F \varepsilon'^a L'_a \circ R_a \alpha R'_a L'_a \circ R_a L_a R_a \alpha \\
&= R'_a \varepsilon'^a L'_a \circ R_a \alpha R'_a L'_a \circ R_a L_a R_a \alpha .
\end{aligned}$$

The first equality follows from the naturality of ε^a over α , the second one is a consequence of the second equality in (4.4a), and the fourth one is the requirement for F to commute with the right adjoints, *i.e.* $R_a F = R'_a$. Note that the previous diagram was written down with all the details, but in the remaining ones we will omit any reference to the equalities over the R 's.

The second requirement in (4.13) translates to the following diagram

$$\begin{array}{ccc}
& 1_{\mathcal{A}} & \\
\eta'^a \swarrow & & \searrow \eta^a \\
R_a L_a & \xrightarrow{R_a \alpha} & R'_a L'_a
\end{array} ,$$

whose commutativity property is nothing but the first equality of (4.4a).

The case $\varphi_2 = R_b \beta$, is just a *mutatis mutandis* of the previous case.

That $\varphi_3 : T \longrightarrow {}_{\varphi_1} T_{\varphi_2}$ is a morphisms in ${}_A \mathcal{F}_B$, is equivalent to the commutativity of the following two diagrams

$$\begin{array}{ccc}
R_a L_a R_a L_b & \xrightarrow{R_a L_a R_a \beta} & R_a L_a R'_a L'_b \\
\downarrow R_a \varepsilon^a L_b & & \downarrow R_a \alpha R'_a L'_b \\
R'_a L'_a R'_a L'_b & & \\
\downarrow R'_a \varepsilon'^a L'_b & & \\
R_a L_b & \xrightarrow{R_a \beta} & R'_a L'_b
\end{array} ,
\quad
\begin{array}{ccc}
R_a L_b R_b L_b & \xrightarrow{R_a \beta R_b L_b} & R'_a L'_b R_b L_b \\
\downarrow R_a \varepsilon^b L_b & & \downarrow R'_a L'_b R_b \beta \\
R'_a L'_b R'_b L'_b & & \\
\downarrow R'_a \varepsilon'^b L'_b & & \\
R_a L_b & \xrightarrow{R_a \beta} & R'_a L'_b
\end{array} .$$

Let us check the commutativity of the first one;

$$\begin{aligned}
R'_a \varepsilon'^a L'_b \circ R_a \alpha R'_a L'_b \circ R_a L_a R_a \beta &= R_a F \varepsilon'^a L'_b \circ R_a \alpha R'_a L'_b \circ R_a L_a R_a \beta \\
&= R_a (F \varepsilon'^a L'_b \circ \alpha R'_a) L'_b \circ R_a L_a R_a \beta \\
&= R_a \varepsilon^a F L'_b \circ R_a L_a R_a \beta .
\end{aligned}$$

The two first equalities are self-explanatory, and for the third and final one the second property in (4.4a) was used. For the commutativity of the second diagram,

$$\begin{aligned}
R'_a \varepsilon'^b L'_b \circ R'_a L'_b R_b \beta \circ R_a \beta R_b L_b &= R_a F \varepsilon'^b L'_b \circ R_a F L'_b R_b \beta \circ R_a \beta R_b L_b \\
&= R_a F \varepsilon'^b L'_b \circ R_a \beta R'_b L'_b \circ R_a L_b R_b \beta \\
&= R_a (F \varepsilon'^b \circ \beta R'_b) L'_b \circ R_a L_b R_b \beta \\
&= R_a \varepsilon^b F L'_b \circ R_a L_b R_b \beta \\
&= R_a \beta \circ R_a \varepsilon^b L_b .
\end{aligned}$$

To derive the second equality the naturality of β over $L_b R_b \beta$ was used and to derive the fourth one, the second property in (4.4b) was used. Finally, for the fifth equality, the naturality of ε^b over $L_b R_b \beta$ was used.

That $\varphi_4 : \widehat{T} \longrightarrow {}_{\varphi_2} \widehat{T}_{\varphi_1}$ is a morphism in ${}_B \mathcal{F}_A$ is proved in a similar way.

On the other hand, the first condition in (4.15), translates to the following commutative diagram

$$\begin{array}{ccccc}
R_a L_b R_b L_a & \xrightarrow{R_a L_b R_b \alpha} & R_a L_b R'_b L'_a & \xrightarrow{R_a \beta R'_b L'_a} & R'_a L'_b R'_b L'_a \\
\downarrow R_a \varepsilon^b L_a & & & & \downarrow R'_a \varepsilon'^b L'_a \\
R_a L_a & \xrightarrow{R_a \alpha} & & & R'_a L'_a
\end{array} .$$

The next calculation proves its commutativity:

$$\begin{aligned}
R'_a \varepsilon'^b L'_a \circ R_a \beta R'_b L'_a \circ R_a L_b R_b \alpha &= R_a F \varepsilon'^b L'_a \circ R_a \beta R'_b L'_a \circ R_a L_b R_b \alpha \\
&= (R_a (F \varepsilon'^b L'_a \circ \beta R'_b) L'_a) \circ R_a L_b R_b \alpha \\
&= R_a \varepsilon^b F L'_a \circ R_a L_b R_b \alpha \\
&= R_a (\varepsilon^b F L'_a \circ L_b R_b \alpha) \\
&= R_a (\alpha \circ \varepsilon^b L_a) \\
&= R_a \alpha \circ R_a \varepsilon^b L_a .
\end{aligned}$$

The third equality follows from the second property in (4.4b), and in the fifth one the naturality of ε^b over α was used. The second condition in (4.15) is proved similarly. \square

Now that the well-definition of Υ has been proved, it only remains to show that $\Upsilon(1_{(\mathcal{L}, L_a \dashv R_a, L_b \dashv R_b)}) = 1_{\Upsilon(\mathcal{L}, L_a \dashv R_a, L_b \dashv R_b)}$. This last equality follows easily from the next calculation, $\Upsilon(\overline{1_{\mathcal{L}}}) = (R_a 1_{L_a}, R_b 1_{L_b}, R_a 1_{L_b}, R_b 1_{L_a}) = (1_{R_a L_a}, 1_{R_b L_b}, 1_{R_a L_b}, 1_{R_b L_a})$. For the compatibility with composition, $\Upsilon(\overline{F'} \cdot \overline{F}) = \Upsilon(\overline{F'}) \cdot \Upsilon(\overline{F})$, we have that

$$\begin{aligned} (R_a \alpha'', R_b \beta'', R_a \beta'', R_b \alpha'') &\stackrel{!}{=} (R'_a \alpha', R'_b \beta', R'_a \beta', R'_b \alpha') \cdot (R_a \alpha, R_b \beta, R_a \beta, R_b \alpha) \\ &= (R_a (F \alpha' \circ \alpha), R_b (F \beta' \circ \beta), R_a (F \beta' \circ \beta), R_b (F \alpha' \circ \alpha)) . \end{aligned}$$

Therefore, the equality that has to be fulfilled is $\alpha'' = F \alpha' \circ \alpha$, where $\alpha'' = \varepsilon^a F F' L''_a \circ L_a \eta''^a$. A similar equality takes place for β'' . This equality is verified as follows:

$$\begin{aligned} \varepsilon^a F F' L''_a \circ L_a \eta''^a &= (F \varepsilon'^a \circ \alpha R'_a) F' L''_a \circ L_a \eta''^a \\ &= F \varepsilon'^a F' L''_a \circ \alpha R'_a F' L''_a \circ L_a \eta''^a \\ &= F \varepsilon'^a F' L''_a \circ \alpha R'_a F' L''_a \circ L_a R'_a \alpha' \circ L_a \eta''^a \\ &= F \varepsilon'^a F' L''_a \circ F L'_a R'_a \alpha' \circ \alpha R'_a L'_a \circ L_a \eta''^a \\ &= F \alpha' \circ F \varepsilon'^a L'_a \circ \alpha R'_a L'_a \circ L_a \eta''^a \\ &= F \alpha' \circ \varepsilon F L'_a \circ L_a \eta''^a \\ &= F \alpha' \circ \alpha . \end{aligned}$$

The first equality follows by the second property in (4.4a), and the third one by the first property in (4.4a) for η''^a . For the fourth equality, the naturality of α over $R'_a \alpha'$ was used and for the fifth one, the naturality of ε'^a over α' was required. Finally, for the sixth equality yet again the second property in (4.4a) was used and the definition of α was applied for the seventh equality.

This completes the proof of the functoriality of Υ .

4.3.3 The Unit and the Counit of the Adjunction

The two previous sections give the background to propose an adjunction

$$\mathbf{Mor}(\mathcal{A}, \mathcal{B}) \begin{array}{c} \xleftarrow{\Upsilon} \\ \xrightarrow{\Gamma} \end{array} \mathbf{Adj}(\mathcal{A}, \mathcal{B}) , \quad (4.37)$$

whose unit and counit are defined without any further ado. Let us begin by giving the unit of this adjunction,

$$\nu : 1_{\mathbf{Mor}(\mathcal{A}, \mathcal{B})} \longrightarrow \Upsilon \Gamma .$$

First, in order to define this unit over an object (A, B, T, \widehat{T}) in $\mathbf{Mor}(\mathcal{A}, \mathcal{B})$,

$$\nu(A, B, T, \widehat{T}) : (A, B, T, \widehat{T}) \longrightarrow \Upsilon\Gamma(A, B, T, \widehat{T}) ,$$

$\Upsilon\Gamma(A, B, T, \widehat{T})$ has to be characterized. From the previous sections

$$\Gamma(A, B, T, \widehat{T}, ev, \widehat{ev}) = ((\mathcal{A}, \mathcal{B})^{(A, B)}, D^a \dashv U^a, D^b \dashv U^b) .$$

Therefore, we need to construct the object $\Upsilon((\mathcal{A}, \mathcal{B})^{(A, B)}, D^a \dashv U^a, D^b \dashv U^b)$. For the part involving the monad on \mathcal{A} , we have

$$(U^a D^a, U^a \varepsilon^{D^a U^a} D^a, \eta^{U^a D^a}) = (A, \mu^A, \eta^A) .$$

Note that this result resembles the statement in Proposition 2.1.2, that is to say, the monad induced by the adjunction $D^a \dashv U^a$ is one of the monads that constructs precisely this adjunction, in this case (A, μ^A, η^A) .

For the part involving the monad on \mathcal{B} ,

$$(U^b D^b, U^b \varepsilon^{D^b U^b} D^b, \eta^{U^b D^b}) = (B, \mu^B, \eta^B) ,$$

in a similar way.

For the part corresponding to T ,

$$(U^a D^b, U^a \varepsilon^{D^a U^a} D^b, U^a \varepsilon^{D^b U^b} D^b) ,$$

where

$$\begin{aligned} U^a D^b Y &= U^a(TY, BY) = TY , \\ U^a \varepsilon^{D^a U^a} D^b Y &= U^a \varepsilon^{D^a U^a}((TY, \lambda Y), (BY, \mu^B Y), \rho Y, \widehat{ev} Y) = U^a(\overline{\lambda Y}, \overline{\widehat{ev} Y}) = \lambda Y , \\ U^a \varepsilon^{D^b U^b} D^b Y &= U^a \varepsilon^{D^b U^b}((TY, \lambda Y), (BY, \mu^B Y), \rho Y, \widehat{ev} Y) = U^a(\overline{\rho Y}, \overline{\mu^B Y}) = \rho Y . \end{aligned}$$

Therefore,

$$(U^a D^b, U^a \varepsilon^{D^a U^a} D^b, U^a \varepsilon^{D^b U^b} D^b) = (T, \lambda, \rho) .$$

For the part corresponding to \widehat{T} , we can obtain in a similar way

$$(U^b D^a, U^b \varepsilon^{D^b U^b} D^a, U^b \varepsilon^{D^a U^a} D^a) = (\widehat{T}, \widehat{\lambda}, \widehat{\rho}) .$$

For the part corresponding to ev ,

$$U^a \varepsilon^{D^b U^b} D^a ,$$

then for X in \mathcal{A} ,

$$U^a \varepsilon^{D^b U^b} D^a X = U^a \varepsilon^{D^b U^b} ((AX, \mu^A X), (\widehat{T}, \widehat{\lambda}), evX, \widehat{\rho}X) = U^a (\overline{evX}, \widehat{\lambda}X) = evX .$$

That is to say,

$$U^a \varepsilon^{D^b U^b} D^a = ev .$$

For the part corresponding to \widehat{ev} , we can get in a similar way that

$$U^b \varepsilon^{D^a U^a} D^b = \widehat{ev} .$$

All this is summarized by saying that $\Upsilon\Gamma(A, B, T, \widehat{T}, ev, \widehat{ev}) = (A, B, T, \widehat{T}, ev, \widehat{ev})$. Therefore, the unit of the adjunction is nothing but the identity natural transformation for $\mathbf{Mor}(\mathcal{A}, \mathcal{B})$. For the object $(A, B, T, \widehat{T}, ev, \widehat{ev})$,

$$\nu(A, B, T, \widehat{T}, ev, \widehat{ev}) = 1_{(A, B, T, \widehat{T})} = (1_A, 1_B, 1_T, 1_{\widehat{T}}) . \quad (4.38)$$

In order to define the counit,

$$\varsigma : \Gamma\Upsilon \longrightarrow 1_{\mathbf{Adj}(\mathcal{A}, \mathcal{B})} ,$$

the value of the functor $\Gamma\Upsilon$ has to be determined over the object $(\mathcal{L}, L_a \dashv R_a, L_b \dashv R_b)$ in $\mathbf{Adj}(\mathcal{A}, \mathcal{B})$. In order to do so, the functor Υ is applied first, to obtain

$$\Upsilon(\mathcal{L}, L_a \dashv R_a, L_b \dashv R_b) = (R_a L_a, R_b L_b, R_a L_b, R_b L_a, R_a \varepsilon^b L_a, R_b \varepsilon^a L_b) ,$$

and then the functor Γ ,

$$\Gamma(R_a L_a, R_b L_b, R_a L_b, R_b L_a, R_a \varepsilon^b L_a, R_b \varepsilon^a L_b) = ((\mathcal{A}, \mathcal{B})^{(R_a L_a, R_b L_b)}, D_{LR}^a \dashv U_{LR}^a, D_{LR}^b \dashv U_{LR}^b) .$$

Thus, for an object $(\mathcal{L}, L_a \dashv R_a, L_b \dashv R_b)$, the counit can be given as

$$\varsigma(\mathcal{L}, L_a \dashv R_a, L_b \dashv R_b) : ((\mathcal{A}, \mathcal{B})^{(R_a L_a, R_b L_b)}, D_{LR}^a \dashv U_{LR}^a, D_{LR}^b \dashv U_{LR}^b) \xrightarrow{\overline{K^{LR}}} (\mathcal{L}, L_a \dashv R_a, L_b \dashv R_b),$$

where $\overline{K^{LR}}$ is a morphism in $\mathbf{Adj}(\mathcal{A}, \mathcal{B})$, that is to say, a functor $K^{LR} : \mathcal{L} \longrightarrow (\mathcal{A}, \mathcal{B})^{(R_a L_a, R_b L_b)}$. This functor is defined over objects as

$$K^{LR}Z = ((R_a Z, R_a \varepsilon^a Z), (R_b Z, R_b \varepsilon^b Z), R_a \varepsilon^b Z, R_b \varepsilon^a Z),$$

and over morphisms $z : Z \longrightarrow Z'$ it is defined as

$$K^{LR}z = (R_a z, R_b z).$$

This definition should be compared with that of the comparison functor K^F defined in Proposition 2.1.4, for a monad (F, μ^F, η^F) . Before resuming the description of the adjunction let us state and prove the following

Proposition 4.3.3.1. *K^{LR} is well-defined and it is a functor.*

Proof:

The functor K^{LR} is well-defined on objects.

That $(R_a Z, R_a \varepsilon^a Z)$ is an object in $\mathcal{A}^{R_a L_a}$ is proved by translating the diagrams in (2.9) for the monad given by $R_a L_a$. The resulting diagrams commute because of the naturality of ε^a over $\varepsilon^a Z$ and because of the triangular identity associated to the right adjoint R_a , respectively.

That $(R_b Z, R_b \varepsilon^b Z)$ is an object in $\mathcal{B}^{R_b L_b}$ follows by similar arguments.

The commutativity of the diagrams in (4.18) for an Eilenberg-Moore category are fulfilled. For example, the first diagram, when translated, looks like $R_a \varepsilon^a Z \cdot R_a \varepsilon^b L_a R_a Z = R_a \varepsilon^b Z \cdot R_a L_b R_b \varepsilon^a Z$ and this is nothing but applying the functor R_a to the naturality of ε^b over $\varepsilon^a Z$. The second diagram is translated to $R_a \varepsilon^a Z \cdot R_a \varepsilon^b L_a R_a Z = R_a \varepsilon^b Z \cdot R_a L_b R_b \varepsilon^a Z$ which holds since it is the functor R_a applied to the naturality of ε^b over $\varepsilon^b Z$.

The pair of diagrams in (4.19) are proved similarly, *i.e.* the first one because of the functor R_b applied to the naturality of ε^a over $\varepsilon^b Z$ and the second one because the functor R_b has been applied to the naturality of ε^a over $\varepsilon^a Z$.

The functor K^{LR} is well-defined on morphisms.

In order to prove this statement let $z : Z \longrightarrow Z'$ be a morphism in \mathcal{L} . Then $R_a z$ is a morphism in $\mathcal{A}^{R_a L_a}$ because of the naturality of ε^a over z . That $R_b z$ is a morphism in $\mathcal{B}^{R_b L_b}$ follows in the same way.

It remains to show that the maps fulfill the requirements given in (4.21). Let us start with the first one, which translates to $R_a \varepsilon^b Z' \cdot R_a L_b R_b z = R_a z \cdot R_a \varepsilon^b Z$. This equality holds because it is the result of applying the functor R_a to the naturality of ε^b over z . And the second requirement in (4.21) also holds, because it is the result of applying the functor R_b to the naturality of ε^a over z .

The functoriality of K^{LR} .

Let Z be an object in \mathcal{L} and 1_Z its unit, then $K^{LR}(1_Z) = (R_a 1_Z, R_b 1_Z) = (1_{R_a Z}, 1_{R_b Z}) = 1_{(R_a Z, R_b Z)} = 1_{K^{LR}(Z)}$. Let $z' \cdot z$ be a composite in \mathcal{L} , therefore $K^{LR}(z' \cdot z) = (R_a(z' \cdot z), R_b(z' \cdot z)) = (R_a z', R_b z') \cdot (R_a z, R_b z) = K^{LR}(z') \cdot K^{LR}(z)$. \square

After the proof of this proposition, it only remains to check the commutativity with the right adjoints. First,

$$U_{LR}^a \cdot K^{LR} Z = U_{LR}^a (R_a Z, R_b Z) = R_a Z \quad ,$$

and the same argument can be applied to R_b . Therefore, the counit can be defined as

$$\zeta(\mathcal{L}, L_a \dashv R_a, L_b \dashv R_b) = \overline{K^{LR}} \quad . \quad (4.39)$$

The naturality of the counit is proved as follows. Let $\overline{F} : (\mathcal{L}, L_a \dashv R_a, L_b \dashv R_b) \longrightarrow (\mathcal{L}', L'_a \dashv R'_a, L'_b \dashv R'_b)$. We need to show that the following diagram of underlying functors

$$\begin{array}{ccc} \Gamma\Upsilon(\mathcal{L}') & \xrightarrow{\Gamma\Upsilon(\overline{F})} & \Gamma\Upsilon(\mathcal{L}) \\ \uparrow \zeta_{\mathcal{L}'} & & \uparrow \zeta_{\mathcal{L}} \\ \mathcal{L}' & \xrightarrow{F} & \mathcal{L} \end{array}$$

commutes.

Since it is a diagram of functors, the commutativity has to be proved for objects and for morphisms. Let Z' be an object in \mathcal{L}' , then

$$\begin{aligned}
(\Gamma\Upsilon F \cdot \zeta\mathcal{L}')Z' &= \Gamma\Upsilon F((R'_a Z', R'_a \varepsilon'^a Z'), (R'_b Z', R'_b \varepsilon'^b Z'), R'_a \varepsilon'^b Z', R'_b \varepsilon'^a Z') \\
&= \Gamma(R_a \alpha, R_b \beta, R_a \beta, R_b \alpha)((R'_a Z', R'_a \varepsilon'^a Z'), (R'_b Z', R'_b \varepsilon'^b Z'), R'_a \varepsilon'^b Z', R'_b \varepsilon'^a Z') \\
&= (R'_a Z', R'_a \varepsilon'^a Z' \cdot R_a \alpha R'_a Z'), (R'_b Z', R'_b \varepsilon'^b Z' \cdot R_b \beta R'_b Z'), \\
&\quad R'_a \varepsilon'^b Z' \cdot R_a \beta R'_b Z', R'_b \varepsilon'^a Z' \cdot R_b \alpha R'_a Z') \\
&= (R_a F Z', R_a F \varepsilon'^a Z' \cdot R_a \alpha R'_a Z'), (R_b F Z', R_b F \varepsilon'^b Z' \cdot R_b \beta R'_b Z'), \\
&\quad R_a F \varepsilon'^b Z' \cdot R_a \beta R'_b Z', R_b F \varepsilon'^a Z' \cdot R_b \alpha R'_a Z') \\
&= (R_a F Z', R_a \varepsilon^a F Z'), (R_b F Z', R_b \varepsilon^b Z'), R_a \varepsilon^b F Z', R_b \varepsilon^a F Z') \\
&= (\zeta\mathcal{L} \cdot F)(Z') .
\end{aligned}$$

In the first three equalities just the definitions of the involved functors are used. In the fourth equality, R' 's are substituted by the RF 's, and in the fifth equality, the second equalities of (4.4a) and (4.4b) were used.

Over morphisms, the calculation goes as follows:

$$\begin{aligned}
(\Gamma\Upsilon F \cdot \zeta\mathcal{L}')z &= \Gamma\Upsilon F(\overline{R'_a z}, \overline{R'_b z}) \\
&= \Gamma(R_a \alpha, R_b \beta, R_a \beta, R_b \alpha)(\overline{R'_a z}, \overline{R'_b z}) \\
&= (\overline{R'_a z}, \overline{R'_b z}) \\
&= (\overline{R_a F z}, \overline{R_b F z}) \\
&= (\zeta\mathcal{L} \cdot F)(z) .
\end{aligned}$$

This completes the proof of the naturality of the counit.

Let us proceed to prove the triangular identities for the adjunction (4.37). In order to do so, let us begin with the triangular identity associated to the left adjoint Γ ,

$$\zeta\Gamma \circ \Gamma\nu = 1_\Gamma . \quad (4.40)$$

Let (A, B, T, \widehat{T}) be an object in $\mathbf{Mor}(\mathcal{A}, \mathcal{B})$, by breaking down the composition, we have

$$\Gamma\nu(A, B, T, \widehat{T}) = \Gamma(1_A, 1_B, 1_T, 1_{\widehat{T}}) = \bar{1}_{(\mathcal{A}, \mathcal{B})^{(A, B)}} .$$

On the other hand,

$$\zeta\Gamma(A, B, T, \widehat{T}) = \zeta((\mathcal{A}, \mathcal{B})^{(A, B)}, D^a \dashv U^a, D^b \dashv U^b) ,$$

which amounts to the following functor

$$K^{DU} : (\mathcal{A}, \mathcal{B})^{(A, B)} \longrightarrow (\mathcal{A}, \mathcal{B})^{(D^a U^a, D^b U^b)} ,$$

where $D^a U^a = A$. Let $((M, {}^A\chi_M), (N, {}^B\chi_N), v, w)$ be an object in $(\mathcal{A}, \mathcal{B})^{(A, B)}$, then

$$\begin{aligned} K^{DU}((M, {}^A\chi_M), (N, {}^B\chi_N), v, w) &= ((U^a(M, N), U^a\varepsilon^a(M, N)), (U^b(M, N), U^b\varepsilon^b(M, N)), \\ &\quad U^a\varepsilon^b(M, N), U^b\varepsilon^a(M, N)) \\ &= ((M, U^a({}^A\bar{\chi}_M, \bar{w})), (N, U^b(\bar{v}, {}^B\bar{\chi}_N)), U^a(\bar{v}, {}^B\bar{\chi}_N), U^b({}^A\bar{\chi}_M, \bar{w})) \\ &= ((M, {}^A\chi_M), (N, {}^B\chi_N), v, w) , \end{aligned}$$

and for morphisms, (\bar{f}, \bar{g}) in $(\mathcal{A}, \mathcal{B})^{(A, B)}$,

$$K^{DU}(\bar{f}, \bar{g}) = (\overline{U^a(\bar{f}, \bar{g})}, \overline{U^b(\bar{f}, \bar{g})}) = (\bar{f}, \bar{g}) .$$

Thus $K^{DU} = 1_{(\mathcal{A}, \mathcal{B})^{(A, B)}}$. All this amounts to the following conclusion,

$$\bar{1}_{(\mathcal{A}, \mathcal{B})^{(A, B)}} \cdot \bar{1}_{(\mathcal{A}, \mathcal{B})^{(A, B)}} = \bar{1}_{(\mathcal{A}, \mathcal{B})^{(A, B)}} ,$$

which is the required equality.

Let us prove the triangular identity associated to the right adjoint Υ , namely

$$\Upsilon\zeta \circ \nu\Upsilon = 1_\Upsilon . \tag{4.41}$$

Let $(\mathcal{L}, L_a \dashv R_a, L_b \dashv R_b)$ be a double adjunction, then breaking down the composition, we have first

$$\begin{aligned} \nu\Upsilon(\mathcal{L}, L_a \dashv R_a, L_b \dashv R_b) &= \nu(R_a L_a, R_b L_b, R_a L_b, R_b L_a, R_a \varepsilon^b L_a, R_b \varepsilon^a L_b) \\ &= (1_{R_a L_a}, 1_{R_b L_b}, 1_{R_a L_b}, 1_{R_b L_a}) . \end{aligned}$$

On the other hand,

$$\begin{aligned} \Upsilon\zeta(\mathcal{L}, L_a \dashv R_a, L_b \dashv R_b) &= \Upsilon(\overline{K^{DU}} : (\mathcal{A}, \mathcal{B})^{(R_a L_a, R_b L_a)}, D^a \dashv U^a, D^b \dashv U^b) \longrightarrow (\mathcal{L}, L_a \dashv R_a, L_b \dashv R_b) \\ &= (U^a \tilde{\alpha}, U^a \tilde{\beta}, U^a \tilde{\beta}, U^b \tilde{\alpha}) , \end{aligned}$$

where $\tilde{\alpha}$ is the composite

$$D^a \xrightarrow{D^a \eta^a} D^a R_a L_a = D^a U^a K^{DU} L_a \xrightarrow{\varepsilon^{D^a U^a} K^{DU} L_a} K^{DU} L_a ,$$

and similarly for $\tilde{\beta}$. The first component for $\Upsilon\zeta(\mathcal{L}, L_a \dashv R_a, L_b \dashv R_b)$ over the object Z in \mathcal{L} comes out as

$$\begin{aligned} U^a \tilde{\alpha} Z &= U^a \varepsilon^{D^a U^a} K^{DU} L_a Z \cdot U^a D^a \eta^a Z \\ &= U^a \varepsilon^{D^a U^a} ((R_a L_a Z, R_a \varepsilon^a L_a Z), (R_b L_b Z, R_b \varepsilon^b L_b Z), R_a \varepsilon^b L_a Z, R_b \varepsilon^b L_a Z) \cdot U^a (R_a L_a \eta^a Z, R_a L_b \eta^a Z) \\ &= U^a (R_a \varepsilon^a L_a Z, R_b \varepsilon^a L_a Z) \cdot R_a L_a \eta^a Z \\ &= R_a \varepsilon^a L_a Z \cdot R_a L_a \eta^a Z \\ &= R_a 1_{L_a} Z \\ &= 1_{R_a L_a} Z . \end{aligned}$$

In the previous calculation several definitions given in this section were used. The only equality highlighted is the fifth one, where the triangular identity associated to the left adjoint L_a was used.

On the other hand, $\tilde{\beta} = \varepsilon^{D^b U^b} K^{DU} L_b \circ D^b \eta^b = 1_{R_b L_b}$. Hence,

$$\Upsilon\zeta(\mathcal{L}, L_a \dashv R_a, L_b \dashv R_b) = (U^a \tilde{\alpha}, U^a \tilde{\beta}, U^a \tilde{\beta}, U^b \tilde{\alpha}) = (1_{R_a L_a}, 1_{R_b L_b}, 1_{R_a L_b}, 1_{R_b L_a}) .$$

Substituting the components of the composition,

$$(1_{R_a L_a}, 1_{R_b L_b}, 1_{R_a L_b}, 1_{R_b L_a}) \circ (1_{R_a L_a}, 1_{R_b L_b}, 1_{R_a L_b}, 1_{R_b L_a}) = (1_{R_a L_a}, 1_{R_b L_b}, 1_{R_a L_b}, 1_{R_b L_a}) .$$

where the last result was the one looked for in (4.41). In summary, one can state the following proposition which holds since the unit of the adjunction (4.37), ν , is the identity natural transformation, see [25].

Proposition 4.3.3.2. (Γ, Υ) is an adjoint pair, and Γ is full and faithful. \square

4.4 Moritability

In this section, the necessary and sufficient conditions for the functor $K^{LR} : \mathcal{L} \longrightarrow (\mathcal{A}, \mathcal{B})^{(R_a L_a, R_b L_b)}$ to be an equivalence of categories are given, this equivalence renders a Beck-type theorem for a categorical Morita context. In order to do so, let us begin by giving the following definition which becomes important in the development of the theory to come.

Definition 4.4.1. *Let $(\mathcal{L}, L_a \dashv R_a, L_b \dashv R_b)$ be an object in $\mathbf{Adj}(\mathcal{A}, \mathcal{B})$. The pair (R_a, R_b) is said to be moritable if and only if the functor K^{LR} is an equivalence of categories.*

Also it is convenient to give the following

Proposition 4.4.2. *Let (A, B, T, \widehat{T}) be an object in $\mathbf{Mor}(\mathcal{A}, \mathcal{B})$ and $(\overline{f}, \overline{g})$ a morphism in $(\mathcal{A}, \mathcal{B})^{(A, B)}$. Then $(\overline{f}, \overline{g})$ is an isomorphism in $(\mathcal{A}, \mathcal{B})^{(A, B)}$ if and only if f and g are isomorphisms in their respective categories.*

Proof:

If $(\overline{f}, \overline{g})$ is an isomorphism in $(\mathcal{A}, \mathcal{B})^{(A, B)}$ then so is $U^a(\overline{f}, \overline{g}) = f$, since functors preserve isomorphisms. Obviously, the same result applies to g .

Suppose that for the morphism $(\overline{f}, \overline{g})$ in $(\mathcal{A}, \mathcal{B})^{(A, B)}$, f and g are isomorphisms, and let f^{-1} and g^{-1} be their respective inverses. Since $(\overline{f}, \overline{g})$ is a morphism in $(\mathcal{A}, \mathcal{B})^{(A, B)}$, it fulfills the requirements given in (4.20) and (4.21). Take the first requirements in each pair, and compose them as showed

$$f^{-1} \cdot ({}^A\chi_{M'} \cdot Af = f \cdot {}^A\chi_M) \cdot Af^{-1} \quad , \quad f^{-1} \cdot (v' \cdot Tg = f \cdot v) \cdot Tg^{-1} \quad .$$

Then ${}^A\chi_M \cdot Af^{-1} = f^{-1} \cdot {}^A\chi_{M'}$ and $v \cdot Tg^{-1} = f^{-1} \cdot v'$, which gives the fulfillment of the first requirements for the inverses. The same can be done for the second requirements. Therefore, $(\overline{f}^{-1}, \overline{g}^{-1})$ is in $(\mathcal{A}, \mathcal{B})^{(A, B)}$. □

We continue with the following

Proposition 4.4.3. *Let (R_a, R_b) be a moritable pair. Then any morphism z in \mathcal{L} such that $R_a z$ and $R_b z$ are isomorphisms is an isomorphism.*

Proof:

Since $R_a z$ and $R_b z$ are isomorphisms in \mathcal{A} and \mathcal{B} , then, by Proposition (4.4.2)

$$(\overline{R_a z}, \overline{R_b z}) = K^{LR} z \quad .$$

is an isomorphism in $(\mathcal{A}, \mathcal{B})^{(A, B)}$. Since K^{LR} is an equivalence of categories, it reflects isomorphisms, therefore z in \mathcal{L} is an isomorphism.

□

Let us give, in order to proceed, another

Definition 4.4.4. *The pair (R_a, R_b) is said to reflect isomorphisms if for z in \mathcal{L} such that $R_a z$ and $R_b z$ are isomorphisms, it can be concluded that z is also an isomorphism.*

In order to analyse the functor $K^{LR} : \mathcal{L} \longrightarrow (\mathcal{A}, \mathcal{B})^{(R_a L_a, R_b L_b)}$ more deeply, the existence of certain colimits in the category \mathcal{L} has to be supposed. Let (M, N) be an object in $(\mathcal{A}, \mathcal{B})^{(A, B)}$, and consider the following diagram in \mathcal{L} ,

$$\begin{array}{ccccccc}
 L_a R_a L_a M & & L_a R_a L_b N & & L_b R_b L_a M & & L_b R_b L_b N & & (\ddagger) \\
 \downarrow L_a R_a L_a \chi_M & \swarrow \varepsilon^a L_a M & \downarrow L_a v & \swarrow \varepsilon^b L_a M & \downarrow L_b w & \swarrow \varepsilon^a L_b N & \downarrow L_b R_b L_b \chi_N & \downarrow L_b R_b L_b \chi_N & \\
 L_a M & & & & & & L_b N & &
 \end{array}$$

This diagram will be referred to as the diagram of type \ddagger for the object (or corresponding to) (M, N) . The colimit of such a diagram is a universal cocone like the following one

$$\begin{array}{ccc}
 L_a M & & L_b N \\
 & \searrow j_{MN}^a & \swarrow j_{MN}^b \\
 & J_{MN} &
 \end{array} \quad (4.42)$$

Now if we consider the morphism $(\bar{f}, \bar{g}) : (M, N) \longrightarrow (M', N')$ in $(\mathcal{A}, \mathcal{B})^{(R_a L_a, R_b L_b)}$ and consider also the following diagram,

$$\begin{array}{ccccccc}
 L_a R_a L_a M & & L_a R_a L_b N & & L_b R_b L_a M & & L_b R_b L_b N \\
 \downarrow L_a R_a L_a f & & \downarrow L_a R_a L_b g & & \downarrow L_b R_b L_a f & & \downarrow L_b R_b L_b g \\
 L_a R_a L_a M' & & L_a R_a L_b N' & & L_b R_b L_a M' & & L_b R_b L_b N' \\
 \downarrow L_a R_a L_a \chi_{M'} & \swarrow \varepsilon^a L_a M' & \downarrow L_a v' & \swarrow \varepsilon^b L_a M' & \downarrow L_b w' & \swarrow \varepsilon^a L_b N' & \downarrow L_b R_b L_b \chi_{N'} & \downarrow L_b R_b L_b \chi_{N'} \\
 L_a M' & & & & & & L_b N' & \\
 & \searrow j_{M'N'}^a & & & \swarrow j_{M'N'}^b & & & \\
 & J_{M'N'} & & & & & &
 \end{array}$$

then since $(J_{M'N'}, j_{M'N'}^a, j_{M'N'}^b)$ is a universal cocone for a diagram of type \ddagger , it is also a cocone for the very previous diagram. For example, begin with $j_{M'N'}^a \cdot L_a^{R_a L_a} \chi_{M'} = j_{M'N'}^a \cdot \varepsilon^a L_a M'$, therefore $j_{M'N'}^a \cdot L_a^{R_a L_a} \chi_{M'} \cdot L_a R_a L_a f = j_{M'N'}^a \cdot \varepsilon^a L_a M' \cdot L_a R_a L_a f$, and so on.

On the other hand, $(\bar{f}, \bar{g}) : (M, N) \longrightarrow (M', N')$ is a morphism in $(\mathcal{A}, \mathcal{B})^{(R_a L_a, R_b L_b)}$, hence the previous equality can be substituted by the following one $j_{M'N'}^a \cdot L_a f \cdot L_a^{R_a L_a} \chi_M = j_{M'N'}^a \cdot L_a f \cdot \varepsilon^a L_a M$, because f is a morphism in $\mathcal{A}^{R_a L_a}$ and because of the naturality of ε^a over $L_a f$. This procedure can be continued with all the morphisms involved in the previous diagram. In summary, $(J_{M'N'}, j_{M'N'}^a \cdot L_a f, j_{M'N'}^b \cdot L_b g)$ is a cocone for the diagram of type \ddagger corresponding to (M, N) . Therefore, there exists a unique morphism $j_{fg} : J_{MN} \rightarrow J_{M'N'}$ such that the bottom pair of diagrams commute

$$\begin{array}{ccccc}
 L_a R_a L_a M & & L_a R_a L_b N & & L_b R_b L_a M & & L_b R_b L_b N \\
 \downarrow L_a^{R_a L_a} \chi_M & \swarrow L_a v & \downarrow \varepsilon^b L_a M & \searrow \varepsilon^a L_b N & \downarrow L_b w & \swarrow \varepsilon^b L_b N & \downarrow L_b^{R_b L_b} \chi_N \\
 L_a M & & & & & & L_b N \\
 \downarrow L_a f & \searrow j_{MN}^a & & & \swarrow j_{MN}^b & & \downarrow L_b g \\
 L_a M' & & J_{MN} & & L_b N' & & \\
 & \searrow j_{M'N'}^a & \downarrow j_{fg} & & \swarrow j_{M'N'}^b & & \\
 & & J_{M'N'} & & & &
 \end{array} . \tag{4.43}$$

The previous procedure allows one to define a functor

$$J : (\mathcal{A}, \mathcal{B})^{(R_a L_a, R_b L_b)} \longrightarrow \mathcal{L} , \tag{4.44}$$

which, over objects (M, N) in $(\mathcal{A}, \mathcal{B})^{(R_a L_a, R_b L_b)}$ and morphisms $(\bar{f}, \bar{g}) : (M, N) \longrightarrow (M', N')$ is defined as

$$J(M, N) = J_{MN} , \tag{4.45a}$$

$$J(\bar{f}, \bar{g}) = j_{fg} , \tag{4.45b}$$

respectively. It is indeed a functor. For a sketch proof, consider $1_{(M, N)} = (1_M, 1_N)$, then $j_{1_M 1_N}$ makes the double rectangle commute in a diagram like (4.43), *i.e.*, $j_{1_M 1_N} \cdot j_{MN}^a = j_{MN}^a \cdot L_a 1_M$ and

so is $1_{J_{MN}}$. Therefore, by uniqueness, $j_{1_M 1_N} = 1_{J_{MN}}$. Also, by uniqueness $J(\bar{f}', \bar{g}') \cdot J(\bar{f}, \bar{g}) = J(\bar{f}'\bar{f}, \bar{g}'\bar{g})$. Once the functor J has been defined, the following lemma can be stated.

Lemma 4.4.5. *Let $(\text{Colim}F, \gamma_i)$ be the colimit of the functor $F : I \rightarrow \mathcal{C}$, and consider the following diagram in \mathcal{C}*

$$\begin{array}{ccc}
 F_i & \xrightarrow{f_{ij}} & F_j \\
 \searrow \gamma_i & & \swarrow \gamma_j \\
 & \text{Colim}F & \\
 & \begin{array}{c} \parallel \\ r \quad s \\ \downarrow \\ \mathcal{C} \end{array} &
 \end{array} ,$$

such that $r \cdot \gamma_i = s \cdot \gamma_i$, for all i in I . Then, $r = s$.

This lemma helps to prove the following

Proposition 4.4.6. *The functor $J : (\mathcal{A}, \mathcal{B})^{(R_a L_a, R_b L_b)} \longrightarrow \mathcal{L}$ is left adjoint to the comparison functor $K^{LR} : \mathcal{L} \longrightarrow (\mathcal{A}, \mathcal{B})^{(R_a L_a, R_b L_b)}$.*

Proof:

i) The unit of the adjunction

$$\eta^{KJ} : 1_{(\mathcal{A}, \mathcal{B})^{(R_a L_a, R_b L_b)}} \longrightarrow K^{LR} J ,$$

has to be a morphism in $(\mathcal{A}, \mathcal{B})^{(R_a L_a, R_b L_b)}$ for any object (M, N) in the same category. First, compute the image of the functor $K^{LR} J$ on (M, N)

$$K^{LR} J(M, N) = K^{LR} J_{MN} = ((R_a J_{MN}, R_a \varepsilon^a J_{MN}), (R_b J_{MN}, R_b \varepsilon^b J_{MN}), R_a \varepsilon^b J_{MN}, R_b \varepsilon^a J_{MN}) .$$

Because of this, the definition of the unit $\eta^{KJ}(M, N)$ is the following

$$\eta^{KJ}(M, N) = (R_a j_{MN}^a \cdot \eta^a M, R_b j_{MN}^b \cdot \eta^b N) . \tag{4.46}$$

This proposal has to be a morphism in $(\mathcal{A}, \mathcal{B})^{(R_a L_a, R_b L_b)}$, that is to say, it has to fulfill the requirements in (4.20) and (4.21). For example, the first requirement for $R_a j_{MN}^a \cdot \eta^a M$ to be an

object in $\mathcal{A}^{R_a L_a}$ is translated to the following diagram

$$\begin{array}{ccccc}
 R_a L_a M & \xrightarrow{R_a L_a \eta^a M} & R_a L_a R_a L_a M & \xrightarrow{R_a L_a R_a j_{MN}^a} & R_a L_a R_a J_{MN} \\
 \downarrow R_a L_a \chi_M & & & & \downarrow R_a \varepsilon^a J_{MN} \\
 M & \xrightarrow{\eta^a M} & R_a L_a M & \xrightarrow{R_a j_{MN}^a} & R_a J_{MN}
 \end{array} .$$

This diagram commutes because of the following calculation,

$$\begin{aligned}
 R_a \varepsilon^a J_{MN} \cdot R_a L_a R_a j_{MN}^a \cdot R_a L_a \eta^a M &= R_a j_{MN}^a \cdot R_a \varepsilon^a L_a M \cdot R_a L_a \eta^a M \\
 &= R_a j_{MN}^a \cdot R_a 1_{L_a M} \\
 &= R_a j_{MN}^a \cdot 1_{R_a L_a M} \\
 &= R_a j_{MN}^a \cdot R_a \varepsilon^a L_a M \cdot \eta^a R_a L_a M \\
 &= R_a j_{MN}^a \cdot R_a L_a R_a L_a \chi_M \cdot \eta^a R_a L_a M \\
 &= R_a j_{MN}^a \cdot \eta^a M \cdot R_a L_a \chi_M ,
 \end{aligned}$$

where in the first equality, the functor R_a was applied to the naturality of ε^a over j_{MN}^a . In the second equality, the triangular identity associated to the left adjoint L_a was used. In the fourth one, the triangular identity associated to the right adjoint R_a was used. In the fifth equality, the property of the cocone was used, in particular, that of j_{MN}^a being a cofork. And finally, in the sixth equality, the naturality of η^a over $R_a L_a \chi_M$ was used.

The fact that $R_b j_{MN}^b \cdot \eta^b N$ is an object in $\mathcal{B}^{R_b L_b}$ is proved similarly.

On the other hand, the requirement given by the first diagram in (4.21) renders, after translation, the following diagram

$$\begin{array}{ccccc}
 R_a L_b N & \xrightarrow{R_a L_b \eta^b N} & R_a L_b R_b L_b N & \xrightarrow{R_a L_b R_b j_{MN}^b} & R_a L_b R_b J_{MN} \\
 \downarrow v & & & & \downarrow R_a \varepsilon^b J_{MN} \\
 M & \xrightarrow{\eta^a M} & R_a L_a M & \xrightarrow{R_a j_{MN}^a} & R_a J_{MN}
 \end{array} ,$$

which commutes because of the following calculation,

$$\begin{aligned}
R_a \varepsilon^b J_{MN} \cdot R_a L_b R_b j_{MN}^b \cdot R_a L_b \eta^b N &= R_a j_{MN}^b \cdot R_a \varepsilon^b L_b N \cdot R_a L_b \eta^b N \\
&= R_a j_{MN}^b \cdot R_a 1_{L_b N} \\
&= R_a j_{MN}^b \cdot 1_{R_a L_b N} \\
&= R_a j_{MN}^b \cdot R_a \varepsilon^a L_b N \cdot \eta^a R_a L_b N \\
&= R_a j_{MN}^a \cdot R_a L_a v \cdot \eta^a R_a L_b N \\
&= R_a j_{MN}^a \cdot \eta^a M \cdot v .
\end{aligned}$$

In the first equality, the functor R_a was applied to the naturality of ε^b over j_{MN}^b . In the second equality, the triangular identity associated to the left adjoint L_b was used. In the fourth equality, the triangular identity associated to the right adjoint R_a was used instead. In the fifth equality, the cocone property was used, in particular, that of j_{MN}^a and j_{MN}^b being a push-out. And finally, in the sixth equality, the naturality of η^a over v was used.

The requirement given in the second diagram in (4.21), is proved similarly. Putting together all of this proves that the unit is well-defined.

Let us proceed to show that the unit is indeed a natural transformation. For such a proof, let $(\bar{f}, \bar{g}) : (M, N) \longrightarrow (M', N')$ be a morphism in $(\mathcal{A}, \mathcal{B})^{(R_a L_a, R_b L_b)}$, then the following diagram must commute

$$\begin{array}{ccc}
(M, N) & \xrightarrow{(\bar{f}, \bar{g})} & (M', N') \\
\downarrow (R_a j_{MN}^a \cdot \eta^a M, R_b j_{MN}^b \cdot \eta^b N) & & \downarrow (R_a j_{M'N'}^a \cdot \eta^a M', R_b j_{M'N'}^b \cdot \eta^b N') \\
(R_a J_{MN}, R_b J_{MN}) & \xrightarrow{(R_a j_{f\bar{g}}, R_b j_{f\bar{g}})} & (R_a J_{M'N'}, R_b J_{M'N'}) .
\end{array}$$

The next calculation shows that the commutativity is fulfilled,

$$\begin{aligned}
(R_a j_{M'N'}^a \cdot \eta^a M' \cdot f, R_b j_{M'N'}^b \cdot \eta^b N' \cdot g) &= (R_a j_{M'N'}^a \cdot R_a L_a f \cdot \eta^a M, R_b j_{M'N'}^b \cdot R_b L_b g \cdot \eta^b N) \\
&= (R_a j_{f\bar{g}} \cdot R_a j_{MN}^a \cdot \eta^a M, R_b j_{f\bar{g}} \cdot R_b j_{MN}^b \cdot \eta^b N) .
\end{aligned}$$

In the first equality, the naturality of η^a over f was applied in the first component and the naturality of η^b over g was used in the second component. In the second equality, the properties of commutativity of the map $j_{f\bar{g}}$ were used.

ii) The counit of the adjunction

$$\varepsilon^{JK} : JK^{LR} \longrightarrow 1_{\mathcal{L}} ,$$

has to be a morphism in \mathcal{L} for any object Z in the same category. Following the same procedure as before, let us first compute the image of the functor JK^{LR} over Z ,

$$JK^{LR}Z = J((R_aZ, R_a\varepsilon^aZ), (R_bZ, R_b\varepsilon^bZ), R_a\varepsilon^bZ, R_b\varepsilon^aZ) = J_{R_aZ R_bZ} =: J_{R_*Z} .$$

In order to construct the counit, let us note that $(Z, \varepsilon^aZ, \varepsilon^bZ)$ is a cocone for a diagram of type \ddagger corresponding to the object (R_aZ, R_bZ) . It is worth to display the cocones to discuss the statement just made

$$\begin{array}{ccccccc}
 & L_a R_a L_a R_a Z & & L_a R_a L_b R_b Z & & L_b R_b L_a R_a Z & & L_b R_b L_b R_b Z \\
 & \Downarrow L_a R_a \varepsilon^a Z & \swarrow L_a R_a \varepsilon^b Z & & \searrow \varepsilon^b L_a R_a Z & & \swarrow \varepsilon^a L_b R_b Z & \Downarrow L_b R_b \varepsilon^b Z \\
 & L_a R_a Z & & & & & & L_b R_b Z \\
 & \swarrow \varepsilon^a Z & & \searrow j_{R_*Z}^a & & \swarrow j_{R_*Z}^b & & \searrow \varepsilon^b Z \\
 & & & J_{R_*Z} & & & & \\
 & & & \downarrow \varepsilon^{JK} & & & & \\
 & & & Z & & & &
 \end{array} ,$$

The map ε^aZ is a cofork for the first parallel vertical arrows because of the naturality of ε^a over ε^aZ . The pair $(\varepsilon^aZ, \varepsilon^bZ)$ is a cocone for the first push-out because of the naturality of ε^a over ε^bZ and it is also a cocone for the second push-out because of the naturality of ε^b over ε^aZ . And finally, the map ε^bZ is a cofork for the right parallel vertical arrows because of the naturality of ε^b over ε^bZ .

Since $(Z, \varepsilon^aZ, \varepsilon^bZ)$ is a cocone, there exists, because of the property of colimits, a unique arrow, termed ε^{JK} which makes the bottom triangular diagrams commute. This unique arrow is the definition of the counit over the object Z

$$\varepsilon^{JK}Z : J_{R_*Z} \longrightarrow Z . \tag{4.47}$$

In order to check for the naturality of the counit, let $z : Z \longrightarrow Z'$ be a morphism in \mathcal{L} , then the diagram

$$\begin{array}{ccc}
 J_{R_*Z} & \xrightarrow{j_{R_*z}} & J_{R_*Z'} \\
 \varepsilon^{JK} Z \downarrow & & \downarrow \varepsilon^{JK} Z' \\
 Z & \xrightarrow{z} & Z'
 \end{array} \tag{4.48}$$

must commute. This diagram can be doubly embedded in the following one.

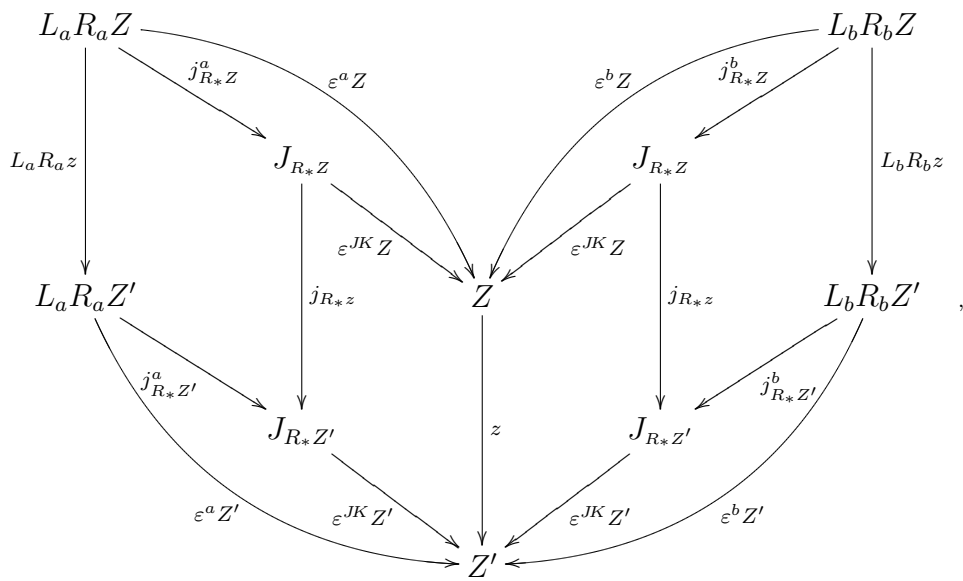

Consider the following calculation,

$$\begin{aligned}
 z \cdot \varepsilon^{JK} Z \cdot j_{R_*Z}^a &= z \cdot \varepsilon^a Z \\
 &= \varepsilon^a Z' \cdot L_a R_a z \\
 &= \varepsilon^{JK} Z' \cdot j_{R_*Z'}^a \cdot L_a R_a z \\
 &= \varepsilon^{JK} Z' \cdot j_{R_*z} \cdot j_{R_*Z}^a \cdot .
 \end{aligned}$$

The first equality follows since $(Z, \varepsilon^a Z, \varepsilon^b Z)$ is a cocone for the diagram of type \ddagger corresponding to the object $(R_a Z, R_b Z)$. The second equality follows because of the naturality of ε^a over z . The third equality follows also because $(Z', \varepsilon^a Z', \varepsilon^b Z')$ is a cocone for the object $(R_a Z', R_b Z')$. And finally, the fourth equality follows because of the commutative property for the map j_{fg} , which in this case is j_{R_*z} .

Likewise,

$$z \cdot \varepsilon^{JK} Z \cdot j_{R_*Z}^b = \varepsilon^{JK} Z' \cdot j_{R_*z} \cdot j_{R_*Z}^b \cdot .$$

Then if Lemma 4.4.5 is invoked, the following equality must hold independently of $j_{R_*Z}^a$ and $j_{R_*Z}^b$,

$$z \cdot \varepsilon^{JK} Z = \varepsilon^{JK} Z' \cdot j_{R_*z} .$$

This is the commutativity requirement for the diagram in (4.48), *i.e.* that the counit is a natural transformation.

iii) The triangular identity associated to the left adjoint J .

The following identity has to be proved,

$$\varepsilon^{JK} J \circ J \eta^{KJ} = 1_J .$$

In order to prove it, let us break down the composition evaluated on the object (M, N) in $(\mathcal{A}, \mathcal{B})^{(R_a L_a, R_b L_b)}$. First,

$$\eta^{KJ}(M, N) = (R_a j_{MN}^a \cdot \eta^a M, R_b j_{MN}^b \cdot \eta^b N) .$$

Then the functor J applied to it looks like,

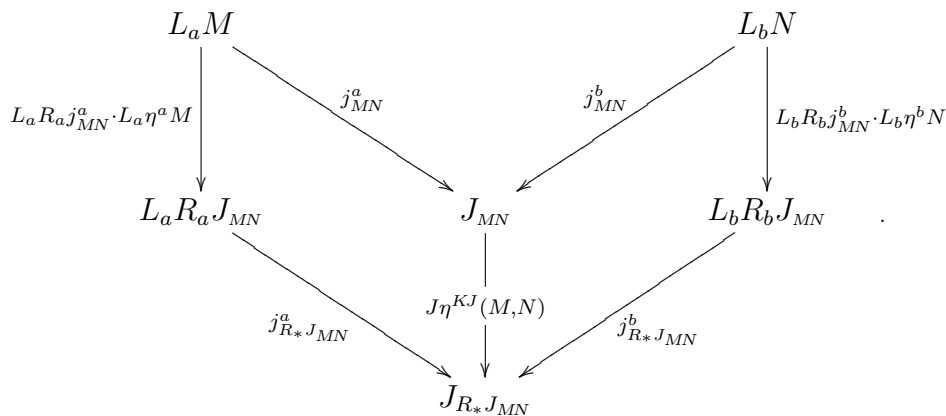

On the other hand, the diagram associated to $\varepsilon^{JK} J(M, N)$, reads

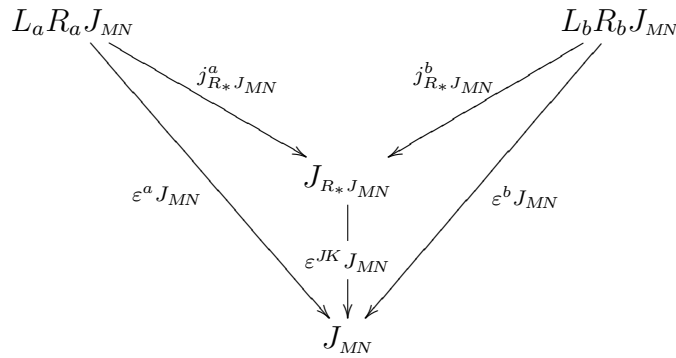

If the last two diagrams are glued one after another, then the resulting diagram can be written down as

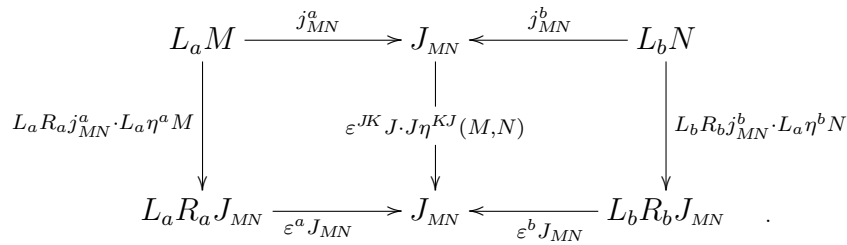

But $\varepsilon^a J_{MN} \cdot L_a R_a j_{MN}^a \cdot L_a \eta^a M = j_{MN}^a \cdot \varepsilon^a L_a M \cdot L_a \eta^a M = j_{MN}^a$, using the naturality of ε^a over j_{MN}^a and the triangular identity associated to the left adjoint L_a , respectively. Likewise, $\varepsilon^b J_{MN} \cdot L_b R_b j_{MN}^b \cdot L_b \eta^b N = j_{MN}^b$.

This means that the following diagram commutes,

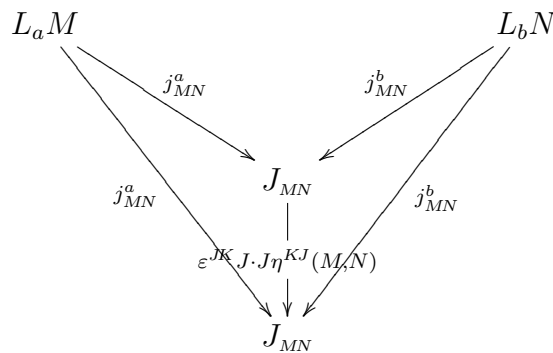

There is, though, another morphism which makes the previous diagram commute, $1_{J_{MN}}$. Due to the universality of the colimit, $\varepsilon^{JK} J \cdot J \eta^{KJ}(M, N) = 1_J(M, N)$, as it was required.

iv) The triangular identity associated to the right adjoint K^{LR} .

The following identity has to be proved

$$K^{LR}\varepsilon^{JK} \circ \eta^{KJ} K^{LR} = 1_{K^{LR}} .$$

In order to do so, let Z be an object in \mathcal{L} , then breaking down the composition we first compute

$$\begin{aligned} \eta^{KJ} K^{LR} Z &= \eta^{KJ} ((R_a Z, R_a \varepsilon^a Z), (R_b Z, R_b \varepsilon^b Z), R_a \varepsilon^b Z, R_b \varepsilon^a Z) \\ &= (R_a j_{R_* Z}^a \cdot \eta^a R_a Z, R_b j_{R_* Z}^b \cdot \eta^b R_b Z) . \end{aligned}$$

On the other hand,

$$K^{LR}\varepsilon^{JK} Z = (R_a \varepsilon^{JK} Z, R_b \varepsilon^{JK} Z) .$$

Therefore, bringing the composition back,

$$\begin{aligned} K^{LR}\varepsilon^{JK} Z \cdot \eta^{KJ} K^{LR} Z &= (R_a \varepsilon^{JK} Z, R_b \varepsilon^{JK} Z) \cdot (R_a j_{R_* Z}^a \cdot \eta^a R_a Z, R_b j_{R_* Z}^b \cdot \eta^b R_b Z) \\ &= (R_a \varepsilon^{JK} Z \cdot R_a j_{R_* Z}^a \cdot \eta^a R_a Z, R_b \varepsilon^{JK} Z \cdot R_b j_{R_* Z}^b \cdot \eta^b R_b Z) \\ &= (R_a \varepsilon^a Z \cdot \eta^a R_a Z, R_b \varepsilon^b Z \cdot \eta^b R_b Z) \\ &= (1_{R_a Z}, 1_{R_b Z}) \\ &= 1_{K^{LR} Z} . \end{aligned}$$

The third equality follows because $(Z, \varepsilon^a Z, \varepsilon^b Z)$ is a cocone for the diagram of type \ddagger corresponding to the object $(R_a Z, R_b Z)$. The fourth equality holds because of the triangular identities associated to the right adjoints R_a and R_b . This completes the proof of the proposition. \square

For the next proposition, the following definition and lemma are needed.

Definition 4.4.7. *The pair (R_a, R_b) converts colimits into coequalizers, if and only if for any object (M, N) in $(\mathcal{A}, \mathcal{B})^{(R_a L_a, R_b L_b)}$, the coforks,*

$$R_a L_a R_a L_a M \begin{array}{c} \xrightarrow{R_a \varepsilon^a L_a M} \\ \xrightarrow{R_a L_a R_a L_a \chi_M} \end{array} \Rrightarrow R_a L_a M \xrightarrow{R_a j_{MN}^a} R_a J_{MN} ,$$

$$R_b L_b R_b L_b N \begin{array}{c} \xrightarrow{R_b \varepsilon^b L_b N} \\ \xrightarrow{R_b L_b R_b L_b \chi_N} \end{array} \Rrightarrow R_b L_b N \xrightarrow{R_b j_{MN}^b} R_b J_{MN} ,$$

are coequalizers.

Lemma 4.4.8. *The following commutative diagram*

$$\begin{array}{ccc}
 R_a L_a R_a L_a M & \xrightarrow[\begin{smallmatrix} R_a L_a R_a L_a \chi_M \\ R_a \varepsilon^a L_a M \end{smallmatrix}]{\cong} & R_a L_a M & \xrightarrow{R_a L_a \chi_M} & M \\
 & & & \searrow^{R_a j_{MN}^a} & \downarrow^{R_a j_{MN}^a \cdot \eta^a M} \\
 & & & & R_a J_{MN}
 \end{array} ,$$

exists, where $R_a j_{MN}^a \cdot \eta^a M$ is a unique arrow.

Proof:

First, $R_a L_a \chi_M$ is a coequalizer for the parallel arrows $R_a \varepsilon^a L_a M$ and $R_a L_a R_a L_a \chi_M$, since it is a split coequalizer with the additional morphisms $(\eta^a R_a L_a M, \eta^a M)$. Since j_{MN}^a is part of a colimit for (M, N) , $R_a j_{MN}^a$ is, in particular, a cofork for the same parallel arrows. Therefore, there must exist a unique arrow from M to $R_a J_{MN}$ that makes the triangle commute.

On the other hand, according to the following calculation

$$\begin{aligned}
 R_a j_{MN}^a \cdot \eta^a M \cdot R_a L_a \chi_M &= R_a j_{MN}^a \cdot R_a L_a R_a L_a \chi_M \cdot \eta^a R_a L_a M \\
 &= R_a j_{MN}^a \cdot R_a \varepsilon^a L_a M \cdot \eta^a R_a L_a M \\
 &= R_a j_{MN}^a \cdot 1_{R_a L_a M} \\
 &= R_a j_{MN}^a ,
 \end{aligned}$$

where the first equality follows from the naturality of η^a over $R_a L_a \chi_M$. The second equality is just the cofork property of $R_a j_{MN}^a$. In the third equality, the triangular identity associated to the right adjoint R_a was used.

The unique arrow induced by the coequalizer must be then $R_a j_{MN}^a \cdot \eta^a M$. □

A similar statement can be written for $R_b j_{MN}^b \cdot \eta^b N$.

Proposition 4.4.9. *The pair of functors (R_a, R_b) converts limits into coequalizers if and only if J is full and faithful.*

Proof:

If (R_a, R_b) converts colimits into coequalizers, then $R_a j_{MN}^a \cdot \eta^a M$ and $R_b j_{MN}^b \cdot \eta^b N$ are isomorphisms, using Lemma 4.4.8, and so is $\eta^{JK}(M, N)$ using Proposition 4.4.2. Note that this argument can be reversed, giving the necessity part of the proof. □

With all this background preparation at hand, the following Beck-type theorem for double adjunctions can be stated.

Theorem 4.4.10. *Let $(\mathcal{L}, L_a \dashv R_a, L_b \dashv R_b)$ be a double adjunction. Then the pair (R_a, R_b) is moritable if and only if the category \mathcal{L} has colimits for the diagrams of type ‡ and the pair (R_a, R_b) reflects isomorphisms and converts colimits into coequalizers.*

Proof:

Suppose that (R_a, R_b) is moritable, then the adjunction

$$(\mathcal{A}, \mathcal{B})^{(R_a L_a, R_b L_b)} \xrightleftharpoons[J]{K^{RL}} \mathcal{L} \quad ,$$

is an equivalence adjunction, hence the unit η^{KJ} is an isomorphism, *i.e.* J is full and faithful according to [25]. By Proposition 4.4.9, the pair (R_a, R_b) converts colimits into coequalizers and reflects isomorphisms by Proposition 4.4.3. Then it only remains to show the existence of colimits of diagrams such as (4.4).

Since K^{LR} is part of an equivalence then it is essentially surjective, that is for an object (M, N) in $(\mathcal{A}, \mathcal{B})^{(R_a L_a, R_b L_b)}$

$$K^{LR}Z = ((R_a Z, R_a \varepsilon^a Z), (R_b Z, \varepsilon^b Z), R_a \varepsilon^b, R_b \varepsilon^a) \cong ((M, {}^{R_a L_a} \chi_M), (N, {}^{R_b L_b} \chi_N), v, w)$$

for an object Z in \mathcal{L} . Consider the cocone $(Z, \varepsilon^a Z, \varepsilon^b Z)$ for the object $(R_a Z, R_b Z)$, which can be represented by the following diagram

$$\begin{array}{ccccccc}
 & L_a R_a L_a R_a Z & & L_a R_a L_b R_b Z & & L_b R_b L_a R_a Z & & L_b R_b L_b R_b Z \\
 & \parallel & & \swarrow & & \searrow & & \parallel \\
 L_a R_a \varepsilon^a Z & \varepsilon^a L_a R_a Z & \xrightarrow{L_a R_a \varepsilon^b Z} & \varepsilon^b L_a R_a Z & \xrightarrow{\varepsilon^a L_b R_b Z} & \varepsilon^b L_b R_b Z & \xrightarrow{L_b R_b \varepsilon^a Z} & L_b R_b \varepsilon^b Z \\
 & \downarrow & & \swarrow & & \searrow & & \downarrow \\
 & L_a R_a Z & & & & & & L_b R_b Z \\
 & \searrow & & & & & & \swarrow \\
 & & \varepsilon^a Z & & & \varepsilon^b Z & & \\
 & & & Z & & & &
 \end{array} .$$

(4.49)

If the functor K^{LR} is applied to the whole of the previous diagram, the new diagram can be obtained,

$$\begin{array}{ccccccc}
 R_*L_aR_aL_aR_aZ & & R_*L_aR_aL_bR_bZ & & R_*L_bR_bL_aR_aZ & & R_*L_bR_bL_bR_bZ \\
 \downarrow R_*L_aR_a\varepsilon^aZ & \nearrow R_*L_aR_a\varepsilon^bZ & \nearrow R_*\varepsilon^bL_aR_aZ & \searrow R_*\varepsilon^aL_bR_bZ & \searrow R_*L_bR_b\varepsilon^aZ & \downarrow R_*L_bR_b\varepsilon^bZ & \\
 R_*L_aR_aZ & & & & & & R_*L_bR_bZ \\
 \searrow R_*\varepsilon^aZ & & & & & & \searrow R_*\varepsilon^bZ \\
 & & & & R_*Z & &
 \end{array} .$$

(4.50)

Remember that R_* stands for (R_a, R_b) , *i.e.* strictly speaking we should have obtained a pair of diagrams, one for each component.

The object $((R_aZ, R_bZ), (R_a\varepsilon^aZ, R_b\varepsilon^aZ), (R_a\varepsilon^bZ, R_b\varepsilon^bZ))$ is a cocone for this diagram, since it is the image of the cocone $(Z, \varepsilon^aZ, \varepsilon^bZ)$ under the functor K^{LR} . This is the proposed colimit for the diagram (4.50). In order to show this property, let (M', N') be an object in $(\mathcal{A}, \mathcal{B})^{(R_aL_a, R_bL_b)}$ such that $((M', N'), (f^a, g^a), (f^b, g^b))$ is a cocone for the diagram (4.50). If the proposed object is a colimit, there must exist a morphism (k, k') in $(\mathcal{A}, \mathcal{B})^{(R_aL_a, R_bL_b)}$, such that the following diagram commutes

$$\begin{array}{ccc}
 (R_aL_aR_aZ, R_bL_aR_aZ) & & (R_aL_bR_bZ, R_bL_bR_bZ) \\
 \searrow (f^a, g^a) & \nearrow (R_a\varepsilon^aZ, R_b\varepsilon^aZ) & \nearrow (R_a\varepsilon^bZ, R_b\varepsilon^bZ) \\
 & (R_aZ, R_bZ) & \\
 & \downarrow (k, k') & \\
 & (M', N') &
 \end{array} .$$

(4.51)

We claim that

$$(k, k') = (f^a \cdot \eta^a R_aZ, g^b \cdot \eta^b R_bZ) . \quad (4.52)$$

First, we are going to prove the commutativity of the diagram and the uniqueness of (k, k') and after that that (k, k') is well-defined, that is to say, (k, k') is a morphism in $(\mathcal{A}, \mathcal{B})^{(R_aL_a, R_bL_b)}$.

For the commutativity of the previous diagram, let us start with the left triangle. That $(k, k') \cdot (R_a \varepsilon^a Z, R_b \varepsilon^a Z) = (f^a, g^a)$, is shown in this way

$$\begin{aligned}
 f^a \cdot \eta^a R_a Z \cdot R_a \varepsilon^a Z &= f^a \cdot R_a L_a R_a \varepsilon^a Z \cdot \eta^a R_a L_a R_a Z \\
 &= f^a \cdot R_a \varepsilon^a L_a R_a Z \cdot \eta^a R_a L_a R_a Z \\
 &= f^a \cdot 1_{R_a} L_a R_a Z \\
 &= f^a .
 \end{aligned}$$

In the first equality, the naturality of η^a over $R_a \varepsilon^a Z$ was used. In the second equality, the fact that f^a is a cofork was used. In the third equality, the triangular identity associated to the right adjoint R_a was used. As far as k' goes,

$$\begin{aligned}
 g^b \cdot \eta^b R_b Z \cdot R_b \varepsilon^a Z &= g^b \cdot R_b L_b R_b \varepsilon^a Z \cdot \eta^b R_b L_a R_a Z \\
 &= g^a \cdot R_b \varepsilon^b L_a R_a Z \cdot \eta^b R_b L_a R_a Z \\
 &= g^a .
 \end{aligned}$$

In the first equality, the naturality of η^b over $R_b \varepsilon^a Z$ was used. In the second equality, the fact that (g^a, g^b) is a push-out was used. Finally, in the third equality, the triangular identity associated to the right adjoint R_b was used. Following the same lines, one proves that $(k, k') \cdot (R_a \varepsilon^b Z, R_b \varepsilon^b Z) = (f^b, g^b)$.

In order to prove that (k, k') is unique, suppose that there exists another pair of maps, (\tilde{k}, \tilde{k}') , such that the commutativity of the triangles takes place, *i. e.*

$$\begin{aligned}
 (f^a, g^a) &= (\tilde{k}, \tilde{k}') \cdot (R_a \varepsilon^a Z, R_b \varepsilon^a Z) , \\
 (f^b, g^b) &= (\tilde{k}, \tilde{k}') \cdot (R_a \varepsilon^b Z, R_b \varepsilon^b Z) .
 \end{aligned}$$

In particular,

$$\begin{aligned}
 f^a &= \tilde{k} \cdot R_a \varepsilon^a Z , \\
 g^b &= \tilde{k}' \cdot R_b \varepsilon^b Z ,
 \end{aligned}$$

then,

$$\begin{aligned}
 f^a \cdot \eta^a R_a Z &= \tilde{k} \cdot R_a \varepsilon^a Z \cdot \eta^a R_a Z = \tilde{k} , \\
 g^b \cdot \eta^b R_b Z &= \tilde{k}' \cdot R_b \varepsilon^b Z \cdot \eta^b R_b Z = \tilde{k}' ,
 \end{aligned}$$

which gives the same definition for (k, k') in (4.52). In the previous calculation, the triangular identities associated to the right adjoints R_a and R_b were used respectively.

Therefore, $((R_a Z, R_b Z), (R_a \varepsilon^a Z, R_b \varepsilon^a Z), (R_a \varepsilon^b Z, R_b \varepsilon^b Z))$ is a colimit for the diagram in (4.50). Since K^{LR} is an equivalence it reflects colimits, hence $(Z, \varepsilon^a Z, \varepsilon^b Z)$ is a colimit for the diagram in (4.49).

In order to finish the proof, it remains to show that $(f^a \cdot \eta^a R_a Z, g^b \cdot \eta^b R_b Z)$ is a morphism in $(\mathcal{A}, \mathcal{B})^{(R_a L_a, R_b L_b)}$.

First, that $f^a \cdot \eta^a R_a Z$ is a morphism in $\mathcal{A}^{R_a L_a}$ means that the following diagram must commute

$$\begin{array}{ccccc} R_a L_a R_a Z & \xrightarrow{R_a L_a \eta^a R_a Z} & R_a L_a R_a L_a R_a Z & \xrightarrow{R_a L_a f^a} & R_a L_a M' \\ \downarrow R_a \varepsilon^a Z & & & & \downarrow R_a L_a \chi_{M'} \\ R_a Z & \xrightarrow{\eta^a R_a Z} & R_a L_a R_a Z & \xrightarrow{f^a} & M' \end{array} .$$

Note that the part corresponding to the action $R_a L_a \chi_M$ under $K^{LR}(Z)$, which is denoted by $K^{LR}(Z)_{R_a L_a \chi_M}$, is $R_a \varepsilon^a Z$. The commutativity follows from the following calculation,

$$\begin{aligned} R_a L_a \chi_{M'} \cdot R_a L_a f^a \cdot R_a L_a \eta^a R_a Z &= f^a \cdot R_a \varepsilon^a L_a R_a Z \cdot R_a L_a \eta^a R_a Z \\ &= f^a \\ &= f^a \cdot \eta^a R_a Z \cdot R_a \varepsilon^a Z . \end{aligned}$$

In the first equality, the fact that f^a is in $\mathcal{A}^{R_a L_a}$ was used. In the second equality, the triangular identity associated to the left adjoint L_a was used. Finally, in the third equality, the commutativity of k in (4.51) was used. That $g^b \cdot \eta^b R_b Z$ is a morphism in $\mathcal{A}^{R_b L_b}$ follows along the same lines.

The first requirement in (4.21) for a morphism of Eilenberg-Moore algebras can be translated to

$$\begin{array}{ccccc} R_a L_b R_b Z & \xrightarrow{R_a L_b \eta^b R_b Z} & R_a L_b R_b L_b R_b Z & \xrightarrow{R_a L_b g^b} & R_a L_b N' \\ \downarrow R_a \varepsilon^b Z & & & & \downarrow v' \\ R_a Z & \xrightarrow{\eta^a R_a Z} & R_a L_a R_a Z & \xrightarrow{f^a} & M' \end{array} .$$

Note that $K^{RL}(Z)_v = R_a \varepsilon^b Z$. The commutativity follows from the following calculation

$$\begin{aligned}
v' \cdot R_a L_b g^b \cdot R_a L_b \eta^b R_b Z &= f^b \cdot R_a \varepsilon^b L_b R_b Z \cdot R_a L_b \eta^b R_b Z \\
&= f^b \\
&= f^b \cdot R_a \varepsilon^a L_b R_b Z \cdot \eta^a R_a L_b R_b Z \\
&= f^a \cdot R_a L_a R_a \varepsilon^b Z \cdot \eta^a R_a L_b R_b Z \\
&= f^a \cdot \eta^a R_a Z \cdot R_a \varepsilon^b Z .
\end{aligned}$$

In the first equality, the fact that (f^b, g^b) is in $(\mathcal{A}, \mathcal{B})^{(R_a L_a, R_b L_b)}$ was used. In the second equality, the triangular identity associated to the left adjoint L_b was used and in the third equality, the triangular identity associated to the right adjoint R_a was used instead. In the fourth equality, the fact that (f^a, f^b) is a push-out was used. Finally, in the fifth equality, the naturality of η^a over $R_a \varepsilon^b Z$ was used. The second requirement in (4.21) is done similarly.

For the converse part of the proof, since the pair (R_a, R_b) converts colimits into coequalizers the functor J is full and faithful, according to Proposition 4.4.9, *i.e.* the unit η^{KJ} is an isomorphism. Therefore if the counit is an isomorphism as well, the proof will be completed. In order to do so, let us look at the definition of the counit on Z ,

$$\begin{array}{ccc}
L_a R_a L_a R_a Z & & \\
\downarrow L_a R_a \varepsilon^a Z & \varepsilon^a L_a R_a Z & \\
L_a R_a Z & & \\
\searrow j_{R_* Z}^a & & \downarrow \varepsilon^{JK} Z \\
& & J_{R_* Z} \\
& & \downarrow \varepsilon^a Z \\
& & Z
\end{array}$$

If the functor R_a is applied to this diagram, then we obtain

$$\begin{array}{ccc}
 R_a L_a R_a L_a R_a Z & & \\
 \begin{array}{c} \Downarrow \\ R_a L_a R_a \varepsilon^a Z \quad R_a \varepsilon^a L_a R_a Z \\ \Downarrow \end{array} & & \\
 R_a L_a R_a Z & \xrightarrow{R_a j_{R_*}^a} & R_a J_{R_*} Z \\
 & \searrow^{R_a \varepsilon^a Z} & \downarrow R_a \varepsilon^{JK} Z \\
 & & R_a Z
 \end{array}$$

It can be noted that since (R_a, R_b) converts colimits into coequalizers, $R_a j_{R_*}^a$ is a coequalizer. On the other hand, $R_a \varepsilon^a Z$ is a split coequalizer with the pair $(\eta^a R_a L_a R_a Z, \eta^a R_a Z)$. Therefore, $R_a \varepsilon^{JK} Z$ must be an isomorphism. By the same arguments, $R_b \varepsilon^{JK} Z$ must be an isomorphism too. The pair (R_a, R_b) reflects isomorphisms, hence $\varepsilon^{JK} Z$ is an isomorphism. \square

4.5 Example

4.5.1 Categories with Binary Coproducts

The following example is based on [11]. Let us look at a special case of the Eilenberg-Moore constructions when the categories involved contain binary coproducts. Suppose that the categories \mathcal{A} and \mathcal{B} have binary coproducts. Suppose further that $(A, B, T, \widehat{T}, ev, \widehat{ev})$ is a Morita context that preserves binary coproducts, *i.e.* A, B, T and \widehat{T} preserve binary coproducts. The following monad (Q, μ^Q, η^Q) can be defined on the product category $\mathcal{A} \times \mathcal{B}$, where the endofunctor Q is defined as

$$Q(X, Y) = (AX + TY, BY + \widehat{T}X) , \quad (4.53)$$

and the natural transformations are defined over the object (X, Y) in $\mathcal{A} \times \mathcal{B}$ as

$$\begin{aligned}
 \mu^Q(X, Y) &= (\mu^A + ev)X + (\lambda + \rho)Y : (AAX + ATY + TBY + T\widehat{T}X, \\
 &\quad BBY + B\widehat{T}X + \widehat{T}AX + \widehat{T}TY) \longrightarrow (AX + TY, BY + \widehat{T}X) , \quad (4.54a)
 \end{aligned}$$

$$\eta^Q(X, Y) = \iota_{XY} \cdot (\eta^A, \eta^B) : (X, Y) \longrightarrow (AX, BY) \longrightarrow (AX + TY, BY + \widehat{T}X) . \quad (4.54b)$$

Here ι_{XY} is a short notation for the canonical injection $(AX, BY) \longrightarrow (AX + TY, BY + \widehat{T}X)$ and $(\mu^A + ev)X : AAX + T\widehat{T}X \longrightarrow AX$ and $(\lambda + \rho)Y : ATY + TBY \longrightarrow TY$ are defined by the colimit of the following diagrams

$$\begin{array}{ccc}
 AAX & \longrightarrow & AAX + T\widehat{T}X \longleftarrow T\widehat{T}X \\
 \searrow \mu^A X & & \downarrow \mu^A X + evX \\
 & & AX \\
 \swarrow evX & & \uparrow evX
 \end{array} , \quad
 \begin{array}{ccc}
 ATY & \longrightarrow & ATY + TBY \longleftarrow TBY \\
 \searrow \lambda Y & & \downarrow \lambda Y + \rho Y \\
 & & TY \\
 \swarrow \rho Y & & \uparrow \rho Y
 \end{array} .$$

The morphisms $(\mu^B + \widehat{ev})Y$ and $(\widehat{\lambda} + \widehat{\rho})Y$ are defined in a similar way.

In this case the Eilenberg-Moore category for the Morita context (A, B, T, \widehat{T}) is isomorphic to the Eilenberg-Moore category of algebras for the monad (Q, μ^Q, η^Q) , *i. e.* $(\mathcal{A}, \mathcal{B})^{(A, B)} \cong (\mathcal{A} \times \mathcal{B})^Q$.

On the other hand, consider a double adjunction $(\mathcal{L}, L_a \dashv R_a, L_b \dashv R_b)$ such that \mathcal{L} has binary coproducts and these coproducts are preserved by the functors R_a and R_b . Then there exists an adjunction

$$\mathcal{A} \times \mathcal{B} \begin{array}{c} \xleftarrow{R_*} \\ \xrightarrow{L_+} \end{array} \mathcal{L} . \quad (4.55)$$

The left adjoint L_+ is defined on objects (X, Y) as $L_a X + L_b Y$, and for morphisms $(h, k) : (X, Y) \longrightarrow (X', Y')$ as $L_a h + L_b k : L_a X + L_b Y \longrightarrow L_a X' + L_b Y'$. The right adjoint R_* is defined on objects Z in \mathcal{L} as $(R_a Z, R_b Z)$ and on morphisms $z : Z \longrightarrow Z'$ as $(R_a z, R_b z) : (R_a Z, R_b Z) \longrightarrow (R_a Z', R_b Z')$.

The monad on $\mathcal{A} \times \mathcal{B}$ defined by the adjunction $L_+ \dashv R_*$ is just the monad (Q, μ^Q, η^Q) corresponding to the Morita context $(R_a L_a, R_b L_b, R_a L_b, R_b L_a)$, and due to the isomorphisms of Eilenberg-Moore categories the moritability of (R_a, R_b) corresponds to the monadicity of R_* .

Appendix

A Structural Properties of $\mathbf{IntCat}(\mathfrak{M})$

This section collects some technical results concerning the 2-category $\mathbf{IntCat}(\mathfrak{M})$.

Remark A.1. Consider the following diagram in a category \mathcal{C} that has equalizers for all parallel arrows

$$\begin{array}{ccccc}
 E & \xrightarrow{f} & A & \begin{array}{c} \xrightarrow{h} \\ \xrightarrow{k} \end{array} & B \\
 \downarrow \widetilde{r \cdot f} & & \downarrow r & & \downarrow s \\
 E' & \xrightarrow{e'} & A' & \begin{array}{c} \xrightarrow{h'} \\ \xrightarrow{k'} \end{array} & B'
 \end{array} ,$$

where f is a fork of the upper parallel arrows h and k , e' is an equalizer for the lower parallel arrows h' and k' . Suppose also that the right square diagram $\widetilde{}$ commutes serially. Then $r \cdot f$ is a fork for the lower parallel arrows and induces a morphism $\widetilde{r \cdot f}$, through the equalizer e' , such that

$$e' \cdot \widetilde{r \cdot f} = r \cdot f .$$

The previous remark helps to write the proofs to come where the category \mathcal{C} is taken to be our usual monoidal category $(\mathfrak{M}, \otimes, I)$ with \otimes -preserved equalizers.

The first lemma to be stated is needed, in particular, to prove that the composition of functors in $\mathbf{IntCat}(\mathfrak{M})$ is a functor, but here it is singled-out for the sake of referencing. This lemma is termed as the *factorization lemma*.

Lemma A.2. *Let C_i be comonoids in \mathfrak{M} , $i = 1, 2, 3$. Assume that $f_0 : C_1 \rightarrow C_2$ and $g_0 : C_2 \rightarrow C_3$ are comonoid morphisms. Take objects M_i and N_i in \mathcal{M}^{C_i} and ${}^{C_i}\mathcal{M}$, $i = 1, 2, 3$, respectively. If the following morphisms are defined*

$$p_1 : M_1^f \rightarrow M_2 \text{ in } \mathcal{M}^{C_2} ,$$

$$p_2 : {}^f N_1 \rightarrow N_2 \text{ in } {}^{C_2}\mathcal{M} ,$$

$$q_1 : M_2^g \rightarrow M_3 \text{ in } \mathcal{M}^{C_3} ,$$

$$q_2 : {}^g N_2 \rightarrow N_3 \text{ in } {}^{C_3}\mathcal{M} ,$$

then the following composition

$$M_1 \square_{C_1} N_1 \xrightarrow{\iota_{gf}} M_1^{gf} \square_{C_3} {}^{gf} N_1 \xrightarrow{q_1 p_1 \square_{C_3} q_2 p_2} M_3 \square_{C_3} N_3$$

is equal to

$$M_1 \square_{C_1} N_1 \xrightarrow{\iota_f} M_1^f \square_{C_2} {}^f N_1 \xrightarrow{p_1 \square_{C_2} p_2} M_2 \square_2 N_2 \xrightarrow{\iota_g} M_2^g \square_{C_3} {}^g N_2 \xrightarrow{q_1 \square_{C_3} q_2} M_3 \square_3 N_3 .$$

Proof:

We prove first that $q_1 \cdot p_1 : M_1^{gf} \rightarrow M_3$ is a morphism in \mathcal{M}^{C_3} . In order to do so, consider the following diagram

$$\begin{array}{ccccc}
 M_1 \otimes C_3 & \xrightarrow{p_1 \otimes C_3} & M_2 \otimes C_3 & \xrightarrow{q_1 \otimes C_3} & M_3 \otimes C_3 \\
 \uparrow M_1 \otimes g & & \uparrow M_2 \otimes g & & \uparrow \rho_{M_3}^{C_3} \\
 M_1 \otimes C_2 & \xrightarrow{p_1 \otimes C_2} & M_2 \otimes C_2 & & \\
 \uparrow M_1 \otimes f & & \uparrow \rho_{M_2}^{C_2} & & \\
 M_1 \otimes C_1 & & & & \\
 \uparrow \rho_{M_1}^{C_1} & & & & \\
 M_1 & \xrightarrow{p_1} & M_2 & \xrightarrow{q_1} & M_3
 \end{array} .$$

- 1) The diagram denoted by (i) commutes because of the bifactoriality of the tensor product \otimes .
- 2) The diagram denoted by (ii) commutes because $p_1 : M_1^f \rightarrow M_2$ is a morphism in \mathcal{M}^{C_2} .
- 3) Finally, the diagram given by (iii) commutes because $q_1 : M_2^g \rightarrow M_3$ is a morphism in \mathcal{M}^{C_3} .

From the commutativity of the previous three diagrams, the commutativity of the outer most diagram follows, which is the required property.

$$\begin{array}{ccccccc}
M_2 \square_{C_2} N_2 & & & & & & \\
\downarrow \iota_g & \searrow \iota_2 & & & & & \\
M_2^g \square_{C_3} {}^g N_2 & \nearrow j_2 & M_2 \otimes N_2 & \xrightarrow[\rho_{M_2}^{C_2} \otimes N_2]{M_2 \otimes C_2 \rho_{N_2}} & M_2 \otimes C_2 \otimes N_2 & \xrightarrow{M_2 \otimes g \otimes N_2} & M_2 \otimes C_3 \otimes N_2 \\
\downarrow q_1 \square_{C_3} q_2 & & \downarrow q_1 \otimes q_2 & & & & \downarrow q_1 \otimes C_3 \otimes q_2 \\
M_3 \square_{C_3} N_3 & \xrightarrow{\iota_3} & M_3 \otimes N_3 & \xrightarrow[\rho_{M_3}^{C_3} \otimes N_3]{M_3 \otimes C_3 \rho_{N_3}} & M_3 \otimes C_3 \otimes N_3 & &
\end{array}$$

a similar conclusion as before can be achieved, namely $\iota_3 \cdot (q_1 \square_{C_2} q_2) \cdot \iota_g = (q_1 \otimes q_2) \cdot \iota_2$. Furthermore, if the previous two diagrams are glued together, the next diagram can be drawn

$$\begin{array}{ccccccccccc}
M_1 \square_{C_1} N_1 & & & & & & & & & & \\
\downarrow \iota_f & \searrow \iota_1 & & & & & & & & & \\
M_1^f \square_{C_2} {}^f N_1 & \nearrow j_1 & M_1 \otimes N_1 & \xrightarrow[\rho_{M_1}^{C_1} \otimes N_1]{M_1 \otimes C_1 \rho_{N_1}} & M_1 \otimes C_1 \otimes N_1 & \xrightarrow{M_1 \otimes f \otimes N_1} & M_1 \otimes C_2 \otimes N_1 & \xrightarrow{M_1 \otimes g \otimes N_1} & M_1 \otimes C_3 \otimes N_1 & & \\
\downarrow p_1 \square_{C_2} p_2 & & \downarrow p_1 \otimes p_2 & & & & \downarrow p_1 \otimes C_2 \otimes p_2 & & \downarrow p_1 \otimes C_3 \otimes p_2 & & \\
M_2 \square_{C_2} N_2 & \searrow \iota_2 & M_2 \otimes N_2 & \xrightarrow[\rho_{M_2}^{C_2} \otimes N_2]{M_2 \otimes C_2 \rho_{N_2}} & M_2 \otimes C_2 \otimes N_2 & \xrightarrow{M_2 \otimes g \otimes N_2} & M_2 \otimes C_3 \otimes N_2 & & & & \\
\downarrow \iota_g & \nearrow j_2 & \downarrow q_1 \otimes q_2 & & & & \downarrow q_1 \otimes C_3 \otimes q_2 & & & & \\
M_2^g \square_{C_3} {}^g N_2 & & & & & & & & & & \\
\downarrow q_1 \square_{C_3} q_2 & & & & & & & & & & \\
M_3 \square_{C_3} N_3 & \xrightarrow{\iota_3} & M_3 \otimes N_3 & \xrightarrow[\rho_{M_3}^{C_3} \otimes N_3]{M_3 \otimes C_3 \rho_{N_3}} & M_3 \otimes C_3 \otimes N_3 & & & & & &
\end{array}$$

Combining the two previous results, we obtain $\iota_3 \cdot (q_1 \square_{C_2} q_2) \cdot \iota_g \cdot (p_1 \square_{C_2} p_2) \cdot \iota_f = (q_1 \otimes q_2) \cdot (p_1 \otimes p_2) \cdot \iota_1$. On the other hand, if the internal arrows of this last diagram are removed and some others are added, the following diagram can be obtained

$$\begin{array}{ccccc}
 M_1 \square_{C_1} N_1 & & & & \\
 \downarrow \iota_{gf} & \searrow \iota_1 & & & \\
 & M_1 \otimes N_1 & \xrightarrow[\rho_{M_1 \otimes N_1}^{C_1}]{M_1 \otimes^{C_1} \rho_{N_1}} & M_1 \otimes C_1 \otimes N_1 & \xrightarrow{M_1 \otimes g \cdot f \otimes N_1} & M_1 \otimes C_3 \otimes N_1 \\
 & \uparrow j_3 & & & & \downarrow q_1 \cdot p_1 \otimes C_2 \otimes q_2 \cdot p_2 \\
 M_1^{gf} \square_{C_3} N_1 & & & & & \\
 \downarrow q_1 p_1 \square_{C_3} q_2 p_2 & & & & & \\
 M_3 \square_{C_3} N_3 & \xrightarrow{\iota_3} & M_3 \otimes N_3 & \xrightarrow[\rho_{M_3 \otimes N_3}^{C_3}]{M_3 \otimes^{C_3} \rho_{N_3}} & M_3 \otimes C_3 \otimes N_3 & . \\
 & & \downarrow q_1 \cdot p_1 \otimes q_2 \cdot p_2 & & & \\
 & & & & &
 \end{array}$$

Then $\iota_3 \cdot (q_1 p_1 \square_{C_3} q_2 p_2) \cdot \iota_{gf} = (q_1 \cdot p_1 \otimes q_2 \cdot p_2) \cdot \iota_1$ as before.

Therefore,

$$\iota_3 \cdot (q_1 p_1 \square_{C_3} q_2 p_2) \cdot \iota_{gf} = \iota_3 \cdot (q_1 \square_{C_2} q_2) \cdot \iota_g \cdot (p_1 \square_{C_2} p_2) \cdot \iota_f ,$$

and since ι_3 is an equalizer

$$(q_1 p_1 \square_{C_3} q_2 p_2) \cdot \iota_{gf} = (q_1 \square_{C_2} q_2) \cdot \iota_g \cdot (p_1 \square_{C_2} p_2) \cdot \iota_f ,$$

as required. □

Proposition A.3. *Let M, N be objects in ${}^C\mathcal{M}^C$. Then the map $\iota : M \square_C N \rightarrow M \otimes N$ is in ${}^C\mathcal{M}^C$.*

Proof:

Consider the following diagram,

$$\begin{array}{ccccc}
 M \square_C N & \xrightarrow{\iota} & M \otimes N & \xrightarrow[\rho_{M \otimes N}^C]{M \otimes^C \rho_N} & M \otimes C \otimes N \\
 \downarrow {}^C\rho_M \square_C N & & \downarrow {}^C\rho_{M \otimes N} & & \downarrow {}^C\rho_{M \otimes C \otimes N} \\
 C \otimes M \square_C N & \xrightarrow{C \otimes \iota} & C \otimes M \otimes N & \xrightarrow[\rho_{C \otimes M \otimes N}^C]{C \otimes M \otimes^C \rho_N} & C \otimes M \otimes C \otimes N , \\
 & & & (i) &
 \end{array}$$

where the inner diagram (i) commutes serially because of the bifactoriality of \otimes and because M is an object in ${}^C\mathcal{M}^C$. The map ι is an equalizer and so is $C \otimes \iota$, due to the preservation of equalizers through the tensor product. In view of Remark A.1, $({}^C\rho_M \otimes N) \cdot \iota = (C \otimes \iota) \cdot ({}^C\rho_M \square_C N)$. This means that ι is a morphism in ${}^C\mathcal{M}$. That ι is a morphism in \mathcal{M}^C is proved similarly. \square

Proposition A.4. *Let $r : R \longrightarrow M \otimes N$ in ${}^C\mathcal{M}^C$ be a fork for the cotensor product $(M \square_C N, \iota)$. Then $\tilde{r} : R \longrightarrow M \square_C N$, the induced morphism by the equalizer ι , is in ${}^C\mathcal{M}^C$.*

Proof:

Consider the following diagram

$$\begin{array}{ccccc}
 R & & & & \\
 \downarrow \tilde{r} & \searrow r & & & \\
 M \square_C N & \xrightarrow{\iota} & M \otimes N & \xrightleftharpoons[\rho_M^C \otimes N]{M \otimes {}^C\rho_N} & M \otimes C \otimes N \\
 \downarrow {}^C\rho_M \square_C N & & \downarrow {}^C\rho_M \otimes N & & \downarrow {}^C\rho_M \otimes C \otimes N \\
 C \otimes M \square_C N & \xrightarrow{C \otimes \iota} & C \otimes M \otimes N & \xrightleftharpoons[C \otimes \rho_M^C \otimes N]{C \otimes M \otimes {}^C\rho_N} & C \otimes M \otimes C \otimes N
 \end{array}$$

Because of Remark A.1, $({}^C\rho_M \otimes N) \cdot \iota = (C \otimes \iota) \cdot ({}^C\rho_M \square_C N)$. Since r is a fork for the upper parallel arrows, $\iota \cdot \tilde{r} = r$. Therefore,

$$({}^C\rho_M \otimes N) \cdot r = (C \otimes \iota) \cdot ({}^C\rho_M \square_C N) \cdot \tilde{r} .$$

The morphism r is in ${}^C\mathcal{M}$, i.e. $({}^C\rho_M \otimes N) \cdot r = (C \otimes r) \cdot {}^C\rho_R$. Due to the bifactoriality of the tensor product $C \otimes r = (C \otimes \iota) \cdot (C \otimes \tilde{r})$, hence

$$({}^C\rho_M \otimes N) \cdot r = (C \otimes r) \cdot {}^C\rho_R = (C \otimes \iota) \cdot (C \otimes \tilde{r}) \cdot {}^C\rho_R .$$

Therefore, $(C \otimes \iota) \cdot ({}^C\rho_M \square_C N) \cdot \tilde{r} = (C \otimes \iota) \cdot (C \otimes \tilde{r}) \cdot {}^C\rho_R$, but $C \otimes \iota$ is a coequalizer, then

$$({}^C\rho_M \square_C N) \cdot \tilde{r} = (C \otimes \tilde{r}) \cdot {}^C\rho_R ,$$

which means that \tilde{r} is a morphism in ${}^C\mathcal{M}$. That \tilde{r} is a morphism in \mathcal{M}^C follows by similar arguments. \square

Corollary A.5. For a morphism of comonoids, $f_0 : C \longrightarrow D$, the morphism $\iota_f : M \square_C N \longrightarrow M^f \square_D^f N$ is in ${}^C\mathcal{M}^C$.

□

Lemma A.6. Let C, D be comonoids in \mathcal{M} . Take the following comodules: a right C -comodule R , left C -comodule S , right D -comodule T , left D -comodule U , and assume that there exists a comonoid morphism $f_0 : C \longrightarrow D$. Consider the following commutative diagram in \mathfrak{M} ,

$$\begin{array}{ccc} R \otimes S & \xrightarrow{r \otimes s} & T \otimes U \\ \uparrow h & & \uparrow k \\ M & \xrightarrow{g} & N \end{array} .$$

Suppose that h and k are forks for $R \square_C S$ and $T \square_D U$, and r and s are morphisms in ${}^D\mathcal{M}^D$. Then there exists an induced commutative diagram

$$\begin{array}{ccccc} R \square_C S & \xrightarrow{\iota_f} & R^f \square_D^f S & \xrightarrow{r \square_D s} & T \square_D U \\ \uparrow \tilde{h} & & & & \uparrow \tilde{k} \\ M & \xrightarrow{g} & & & N \end{array} .$$

Proof:

Consider the following diagrams

$$\begin{array}{ccccc} M & & & & \\ \downarrow \tilde{h} & \searrow h & & & \\ R \square_C S & \xrightarrow{\iota_1} & R \otimes S & \xrightleftharpoons[\rho_R^C \otimes S]{R \otimes^C \rho_S} & R \otimes C \otimes S \end{array}$$

and

$$\begin{array}{ccccccc}
R \square_C S & & & & & & \\
\downarrow \iota_f & \searrow \iota_1 & & & & & \\
R^f \square_D^f S & \xrightarrow{j} & R \otimes S & \xrightarrow[\rho_R^C \otimes S]{R \otimes^C \rho_S} & R \otimes C \otimes S & \xrightarrow{R \otimes f \otimes S} & R \otimes D \otimes S \quad .
\end{array}$$

These diagrams commute. First, because the morphism \tilde{h} is the one induced by the fork h over the equalizer ι_1 . Second, because the morphism ι_f is the one induced by the morphism ι_1 over the equalizer j . These diagrams can be glued together thus giving the following one:

$$\begin{array}{ccccccc}
M & & & & & & \\
\downarrow g & \searrow \tilde{h} & \searrow h & & & & \\
R \square_C S & & & & & & \\
\downarrow \iota_f & \searrow \iota_1 & & & & & \\
R^f \square_D^f S & \xrightarrow{j} & R \otimes S & \xrightarrow[\rho_R^C \otimes S]{R \otimes^C \rho_S} & R \otimes C \otimes S & \xrightarrow{R \otimes f \otimes S} & R \otimes D \otimes S \\
\downarrow r \square_D s & & \downarrow r \otimes s & & (i) & & \downarrow r \otimes D \otimes s \\
T \square_D U & \xrightarrow{\iota_2} & T \otimes U & \xrightarrow[\rho_T^D \otimes U]{T \otimes^D \rho_U} & T \otimes D \otimes U & & \\
\downarrow \tilde{k} & \searrow k & & & & & \\
N & & & & & &
\end{array} \quad .$$

The square diagram corresponding to (i) commutes because of the colinearity of the morphisms r and s . Due to Remark A.1, $(r \otimes s) \cdot j = \iota_2 \cdot (r \square_D s)$. Finally, (ii) commutes because \tilde{k} is the morphism induced by the equalizer ι_2 over the morphism k .

All of this together amounts to

$$\iota_2 \cdot (r \square_D s) \cdot \iota_f \cdot \tilde{h} = (r \otimes s) \cdot j \cdot \iota_f \cdot \tilde{h} = (r \otimes s) \cdot \iota_1 \cdot \tilde{h} = (r \otimes s) \cdot h = k \cdot g = \iota_2 \cdot \tilde{k} \cdot g \quad ,$$

which immediately leads to the conclusion of the lemma. \square

Bibliography

- [1] ABE, E. *Hopf Algebras*. Cambridge Tracts in Math. Cambridge Univ. Press, 1980.
- [2] AGUIAR, M. *Internal Categories and Quantum Groups*. PhD thesis, Cornell University, 1997.
- [3] AWODEY, S. *Category Theory*. Oxford Logic Guides. Oxford, 2006.
- [4] BAEZ, J., AND STAY, M. Physics, topology, logic and computation: A Rosetta stone, 2009.
- [5] BENABOU, J. Introduction to bicategories. In *Reports of the Midwest Category Seminar*, vol. 47 of *Lecture Notes in Math*. Springer Berlin, 1967, pp. 1–77.
- [6] BÖHM, G. Private communication, 2009.
- [7] BORCEUX, F. *Handbook of Categorical Algebra I*. Encyclopedia Math. Appl. Cambridge Univ. Press, 1994.
- [8] BRZEZINSKI, T. A note on coring extensions. *Ann. Univ. Ferrara LI* (2005), 15–27. Corrected version arXiv:math/0410020v3.
- [9] BRZEZINSKI, T., AND TURNER, R. B. The Galois theory of matrix C -rings. *Appl. Categ. Structures* 14, 5-6 (2006), 471–501.
- [10] BRZEZINSKI, T., AND VAZQUEZ-MARQUEZ, A. Kleisli objects for categories internal to monoidal categories, 2009. Preprint.
- [11] BRZEZINSKI, T., VAZQUEZ-MARQUEZ, A., AND VERCRYUSSE, J. The Eilenberg-Moore category and a Beck-type theorem for a Morita context, 2009. To appear in *Appl. Categ. Structures*.
- [12] BRZEZINSKI, T., AND WISBAUER, R. *Corings and Comodules*. London Math. Soc. Lecture Note Ser. Cambridge Univ. Press, 2003.
- [13] CARBONI, A., PEDICCHIO, M., AND PIROVANO, N. Internal graphs and internal groupoids in Mal'cev categories. In *Conf. Proc. Int. Summer Category Theory Meeting 1991, Montreal (1992)*, J. B. CARELL and R. MURTY, Eds., vol. 13, Canad. Math. Soc., pp. 97–109.
- [14] FUCHS, J. The graphical calculus for ribbon categories: Algebras, modules, Nakayama automorphisms. *J. Nonlinear Math. Phys. 13 Supplement* (2006), 44–54.

- [15] GRAY, J. W. *Formal Category Theory: Adjointness for 2-categories*. Lecture Notes in Math. Springer, 1974.
- [16] HEYNEMAN, R., AND SWEEDLER, M. Affine Hopf algebras. *J. Algebra* 13 (1969), 192–241.
- [17] JOYAL, A., AND STREET, R. The geometry of tensor calculus I. *Adv. Math.* 88 (1991), 55–112.
- [18] KELLY, G., AND STREET, R. Review of the elements of 2-categories. In *Category Seminar: Proceedings Sydney Category Theory Seminar 1972 /1973* (1974), G. M. KELLY, Ed., vol. 420 of *Lecture Notes in Mathematics*, Springer, pp. 75–103.
- [19] LACK, S. A 2-categories companion. In *Towards Higher Categories*, J. C. BAEZ and J. P. MAY, Eds., vol. 152 of *IMA Vol. Math. Appl.* Springer New York, 2009, pp. 105–191.
- [20] LACK, S., AND STREET, R. The formal theory of monads II. *J. Pure Appl. Algebra* 175, 1 (2002), 243–265.
- [21] LAMBECK, J. *Introduction to High Order Categorical Logic*. Cambridge Stud. Adv. Math. Cambridge Univ. Press, 1988.
- [22] LAUDA, A. D. Frobenius algebras and ambidextrous adjunctions. *Theory and Applications of Categories* 16, 4 (2006), 84–122.
- [23] LEINSTER, T. *Higher Operads, Higher Categories*. London Math. Soc. Lecture Note Ser. Cambridge University Press, 2004.
- [24] MACDONALD, J., AND SOBRAL, M. Aspects of monads. In *Categorical Foundations: Special Topics in Order, Topology, Algebra and Sheaf Theory*, M. C. PEDICCHIO and W. THOLEN, Eds., vol. 97 of *Encyclopedia Math. Appl.* Cambridge Univ. Press, 2004, pp. 213–267.
- [25] MACLANE, S. *Categories for the Working Mathematician*, 1st ed. Grad. Texts in Math. Springer, 1971.
- [26] MACLANE, S. *Categories for the Working Mathematician*, 2nd ed. Grad. Texts in Math. Springer, 1998.
- [27] PAREIGIS, B. On symbolic computations in braided monoidal categories. In *Hopf Algebras in Noncommutative Geometry and Physics* (2004), S. CAENEPEEL and F. VAN OYSTAEYEN, Eds., vol. 239 of *Lect. Notes Pure Appl. Math.*, CRC Press, p. 344.
- [28] POWER, J. 2-categories. Tech. rep., BRICS NS, 1998.
- [29] ROTMAN, J. J. *An Introduction to Homological Algebra*. Academic Press, 1979.
- [30] STREET, R. The formal theory of monads. *J. Pure Appl. Algebra* 2, 2 (1972), 149–168.